

GASOLINE & LP ENGINE SERVICE



GENERAL SERVICE 71 - 73

KOHLER ENGINE SERVICE 105 - 126

- Carburetor Adjustment (Gasoline Carburetor) 106
- Carburetor Adjustment (LP Gas Carburetor) 109 - 110
- Carburetor Reconditioning (Gasoline Carburetor) 106 - 108
- Carburetor Reconditioning (LP Gas Carburetor) 110 - 112
- Compression Check 105
- Crankcase Breather 105
- Electrical Circuitry 115 - 116
- Electrical Tests 88 - 91
- Engine Reconditioning 117 - 124
- Fuel Pump, Electric 109
- Governor Adjustment 105 - 106
- Ignition Timing 113
- Magneto Service 113 - 114
- Oil Specifications 105
- Technical Data 125 - 126
- Vaporizer - Primary Regulator Service 112

ONAN ENGINE SERVICE 127 - 138

- Carburetor Adjustment 127
- Carburetor Reconditioning (Gasoline) 127
- Carburetor Reconditioning (LP Gas) 128 - 130
- Crankcase Breather 127
- Electrical Circuitry 132
- Electrical Tests 115
- Engine Reconditioning 133 - 137
- Fuel Pump 128
- Governor Adjustment 127
- Ignition Timing 130
- Oil Specifications 127
- Spark Plugs 130
- Tappet Adjustment 131
- Technical Data 138
- Valve System 131
- Vaporizer - Primary Regulator Service 130

WISCONSIN ENGINE SERVICE 75 - 103

- Carburetor Adjustment 76
- Carburetor Reconditioning (Gasoline Carburetor) 76 - 79
- Carburetor Reconditioning (LP Gas Carburetor) . 80 - 81
- Distributor Maintenance 86
- Electrical Circuitry & Tests 87 - 97
- Engine Compression 75
- Engine Reconditioning 98 - 102
- Governor Adjustment 75
- Ignition Timing 85 - 86
- LP Fuel Filter Lock 85
- LP Gas Final Regulator Service 83 - 85
- LP Gas Vaporizer - Primary Regulator Service . 81 - 83

GASOLINE &
LP ENGINES

- Oil Specifications 75
- Spark Plugs 86
- Technical Data 103
- Temperature Safety Switch 86

TROUBLESHOOTING 139 - 142





GASOLINE & LP ENGINE SERVICE

An engine instruction and service manual is furnished by the engine manufacturer for every Bobcat.

CHANGING ENGINE OIL

Engine crankcase oil should be changed after every 50 operating hours. In prolonged operation at temperatures above 90°F the oil should be changed every 25 hours and the filter every 50 hours.

Drain the oil when the engine is hot. After the oil is drained, replace the plug and fill with 7 pints of good quality detergent oil. Do not overfill. If you change the engine oil filter, add one additional pint of oil to the crankcase. Check the oil level.

OIL SPECIFICATIONS

Use good quality detergent motor oil that meets API service classifications MS-DG. Use the proper SAE viscosity for expected temperature conditions AT TIME OF STARTING, not for the highest temperature expected during the work day. Refer to your engine service section for proper oil grade to use at different temperatures.

ENGINE OIL FILTER

The engine oil filter should be changed every 50 hours. When changing the oil filter element, follow these steps:

1. Remove the cover, cartridge and gasket.
2. Clean the filter container thoroughly, removing all oil, sludge, etc.
3. Install a new cartridge and gasket and replace the cover.

Start the engine and run it for about 5 minutes. If there are no leaks around the filter, the cartridge and gasket are installed correctly. Check for oil leaks at the lines and check the engine oil level. Add oil necessary to fill the crankcase (about 1 pint). Do not overfill, as this causes oil foaming, oil consumption, high engine temperatures and oil leaks at all engine seals.

CRANKCASE BREATHER ASSEMBLY

The crankcase breather valve should be inspected and cleaned, if necessary, every 100 hours. A faulty breather valve may cause oil leaks at all engine seals and high engine temperatures. This applies only to the M-444 and M-500 models.

ENGINE AIR CLEANER

The engine air cleaner must be serviced regularly for maximum engine protection. However, overservicing does not use the air cleaner features to the fullest. Set up a schedule and follow it. To service, follow these steps:

1. Empty the dust cup daily or as required to keep it from becoming overfull. Do not disturb the filter cartridge.
2. Change the filter cartridge (element) when the red ring appears in the sight window of the condition indicator. Remove the filter cartridge.
3. Before installing the new or cleaned cartridge, wipe all foreign material from the filter container.
4. Install the clean cartridge carefully to insure proper sealing.
5. Press the reset button on the condition indicator to retract the red ring from the sight window.

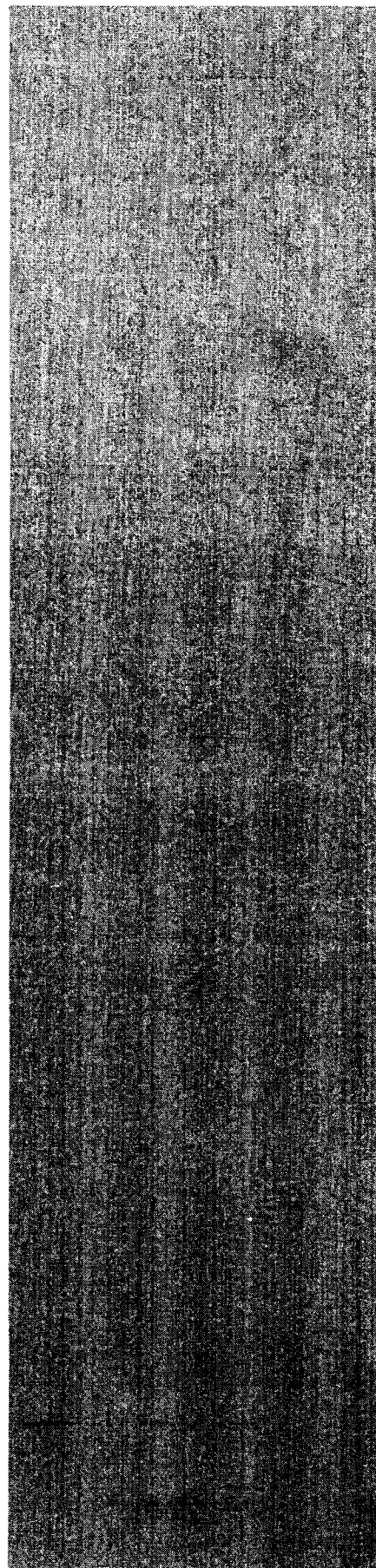

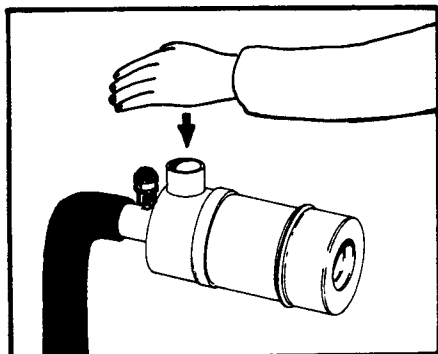
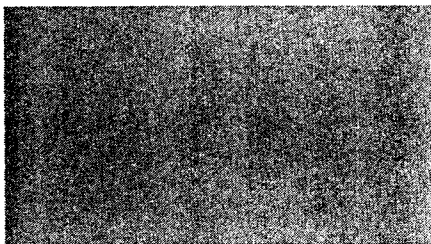
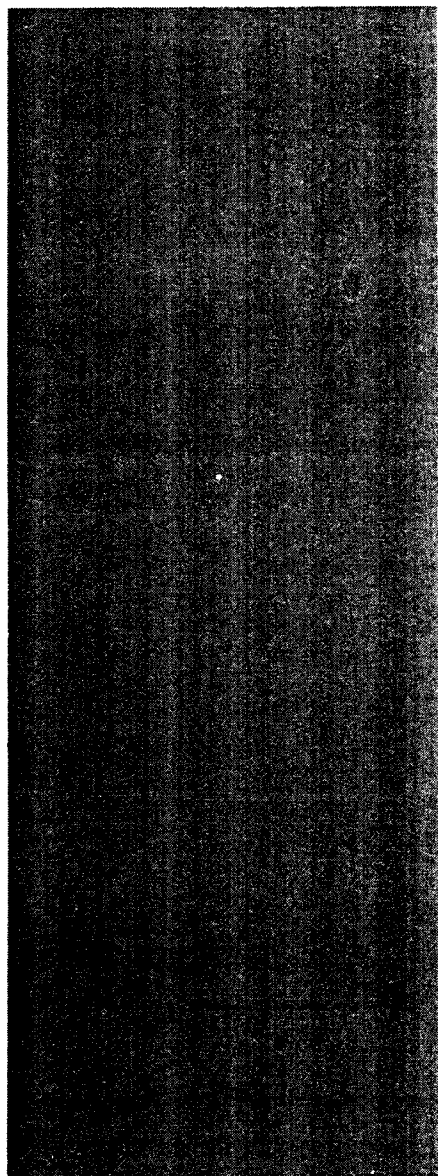

Fig. 171 Dry Type Air Cleaner



NOTE: For minimum loader down-time, replace the filter with a new or cleaned filter cartridge. Clean the filter cartridge at a more convenient time.

You can clean a filter cartridge in this manner:

With a dry air blast, direct dry, clean air up and down the pleats on the clean air side (inside) of the filter cartridge. Air pressure at the nozzle must not exceed 75 PSI. Maintain a reasonable distance between the nozzle and the cartridge. After cleaning, inspect for leaks with a light inside the cartridge.

AIR CLEANER INSPECTION

At every air cleaner service, inspect the following for damage or leaks.

1. dust cap retainer
2. filter gasket
3. dust cup
4. dust cap sealing edge
5. filter leaks
6. hoses and connections

NOTE: Filter cartridge leaks are indicated by areas of dust concentration on the clean side of the filter or by light shining through holes when a light bulb is held inside the filter.

Check the indicator by removing the inlet cap (Figure 171) with the engine running at full RPM. Hold your hand tightly over the inlet and the red ring should come into view in the indicator window.

Air cleaners should be inspected regularly for leaks. A damaged air cleaner can seriously affect the life and performance of an engine.

The following service precautions should be taken when the engine is being serviced in the field:

1. Watch all connections for tightness. Be sure the air cleaner outlet pipe and air inlet hose are complete.
2. If the air cleaner has been dented or damaged, check all connections immediately. Check the internal cartridge sealing areas. Replace the air cleaner body if necessary.
3. In case of leakage, if adjustment does not correct the trouble, replace the necessary parts, hoses or gaskets.
4. Examine the carburetor cross-shafts, etc., for looseness which will cause unfiltered air to enter the engine.
5. Inspect the condition of the intake manifold gasket.

NOTE: You can check the overall condition of the filtering system by removing the air inlet cap from the air cleaner assembly and placing your hand over the inlet with the engine running. The air inlet hose should collapse and the red ring should appear in the sight window of the condition indicator. RPM will decrease and the engine may stop. After checking, press the button on the condition indicator to retract the red ring from the sight window. See Figure 171.

HEAVY DUTY AIR CLEANER

A heavy duty dry-type air cleaner is furnished as an optional extra on some Bobcat Loaders. A condition indicator is located on the front of the air cleaner. A red ring in the window shows that the filter needs service. Remove the element and install a new one; **DO NOT TRY TO CLEAN AND REUSE THE OLD ELEMENT.**

Inspect all hoses and connections for leaks. Make sure that the vacuum line between the filter and aspirator is tight and in good condition. Inspect and clean the swirl vanes on the Farr air cleaner inlet. If these become plugged, the filter cartridge will burn up.

After servicing the air cleaner, press the button located at the bottom of the condition indicator to retract the red ring from the sight window. You may also press this button to make sure that the indicator operates freely, and to acquaint yourself with what the ring will look like when the filter needs service.

GASOLINE SPECIFICATIONS

In gasoline engines used in the Melroe Bobcat Loader, the engine manufacturers recommend using a regular gasoline of over 74 octane.

The use of premium gasoline is NOT recommended for these engines.

When operating in a hot climate or under extremely heavy work conditions the engine may continue to pre-ignite after turning the ignition switch off. If this happens, it may be necessary to clean carbon from the cylinder head and piston areas.

NOTE: There is a fuel tank on each side of the M-500 and M-444 Bobcat Loaders. The M-444 has a fuel capacity of 10 gallons, and the M-500 has a fuel capacity of 9 gallons. A line connecting the two tanks makes it possible to fuel the machine from either side (Figure 172). The M-600 has a fuel capacity of 11 gallons, and can be fueled only from the left side of the machine.

GASOLINE PUMP (M-500 Only)

The M-500 Gasoline model Bobcat is equipped with an electric fuel pump and filter. The pump is designed to provide a constant supply of fuel to the carburetor. The filter at bottom of the pump will have to be changed when fuel will no longer pass freely through it.

Follow these steps to change the fuel filter:

1. With a 5/8" wrench, remove the filter retainer cap.
2. Remove and clean the retainer cap gasket, rubber gasket and magnet.
3. Discard the old filter element.
4. Reassemble the retainer cap, rubber gasket, magnet and new filter element.
5. Replace the retainer cap and tighten it.

Figure 173 shows the assembly of an electric fuel pump.

LP GAS

The LP gas tank is secured to a bracket mounted on the upright crossmember (Figure 174).

These LP engines operate on a liquid withdrawal system. Tank outlet must be from the port marked liquid.

All connections must be secure. Whenever you stop the machine you should close the hand valve on the tank. This will eliminate the chance of flooding the machine with gas.

A fuel filter with an ignition switch actuated shut-off lock is located between the inlet hose and the vaporizer. This must be serviced occasionally.

Use a good quality liquefied petroleum gas (LP Gas).



Stop the engine and shut off the hand valve before refueling, changing tanks, or doing anything with the fuel system. Fuel in a well ventilated area.

ENGINE COOLING SYSTEM

All air cooled engines must have proper air circulation to cool well. Keep all shrouding in place except while cleaning the engine cooling fins.

Keep the blower fan and screen clear of foreign material, and the shrouding free of leaks and dents.

Remove the shrouding and clean the cooling fins as often as necessary.

Backflush the air cooling system daily, if necessary, by blowing compressed air through the cooling air outlet.

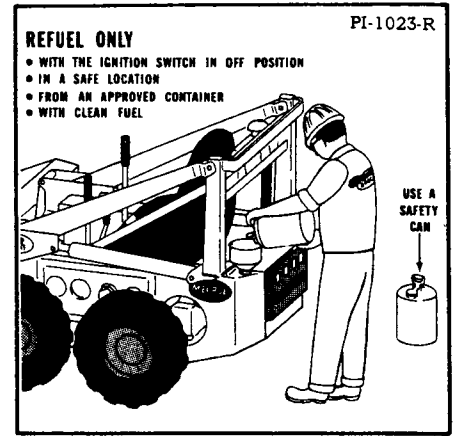

Fig. 172 Filling Fuel Tank

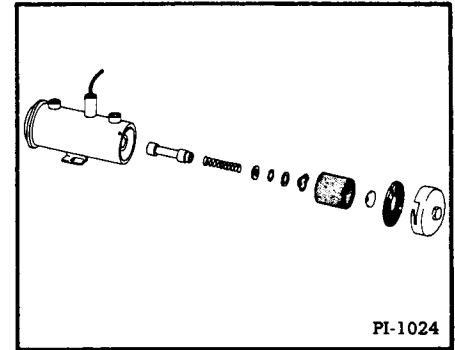

Fig. 173 Electric Fuel Pump

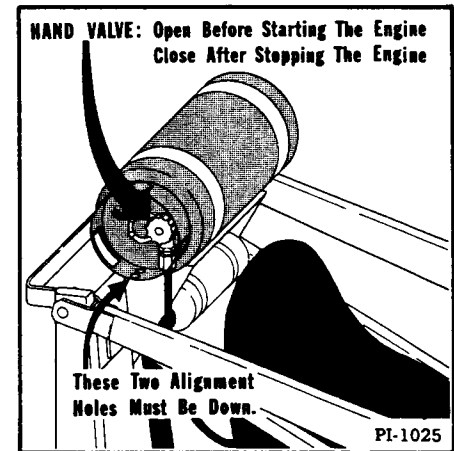

Fig. 174 LP Tank



LP FUEL TANK

Be sure the ignition switch is off before disconnecting the fuel tank connection.

Clean the LP tank connections before installing a new tank.



WISCONSIN ENGINE SERVICE

RESTORING COMPRESSION

On a new engine or on one which has been out of operation for some time, the oil may have drained off the cylinder so that compression will be weak. This may cause difficulty in starting. To remedy this condition, remove the spark plugs and pour about a fluid ounce of engine oil through the spark plug hole into each cylinder.

Turn the engine over several times by hand to distribute the oil over the cylinder walls. Then replace the spark plugs and compression should be satisfactory.

GOVERNOR ADJUSTMENT

The control rod between the governor and carburetor must be adjusted to the proper length, or the governor action will be faulty. With the engine at rest, the governor spring will hold the flyweights in, and the control rod must be of such length as to hold the carburetor throttle wide open at the point. The accuracy of this adjustment can be tested by disconnecting the control rod from the governor lever, then pushing the rod toward the carburetor as far as it will go. This will open the throttle wide. The governor lever should then be moved as far as possible in the same direction; all of this being done with the rod disconnected from the lever. Holding both parts in the above position, the rod should be screwed into the swivel block on the carburetor, until the bent end of the rod will register with the hole in the lever. Then, screw the rod in two more turns. Insert the rod into the hole in the governor lever and insert the cotter pin. With the governor lever pushed toward the carburetor as far as it will go, there should be about 1/16 inch clearance between the throttle lever and the stop pin on the carburetor. The clearance will cause the lever to bounce back from the stop pin, rather than jam against the pin, when a load is suddenly applied to the idling engine. This will eliminate excessive wear on the threads in the carburetor throttle swivel block.

The governor lever is furnished with 12 holes (Figure 176) for attaching the governor spring. For operation in a Bobcat, the spring should be hooked into the No. 10 hole in the arm. This would set the engine speed to 2400 RPM under load.

STORAGE OF ENGINES

Clean the exterior of the engine completely.

To protect the cylinders, pistons, rings and valves from rusting and sticking, a half and half mixture of kerosene and engine oil should be injected into the pipe tap opening on the intake manifold while the engine is warm and running at moderate speed. About a quarter pint is necessary, or enough so a heavy bluish smoke will appear at the exhaust. Shut the engine off. This fogging operation will give a coating of oil on the above mentioned parts, protecting them from the atmosphere.

Drain the oil from the crankcase.

Drain the fuel system.

TEMPERATURE	VISCOSITY
Below 0° F	SAE 5W-20W
0° F to +15° F	SAE 10W
+15° F to +40° F	SAE 20-20W
+40° F to +120° F	SAE 30

Fig. 175 Oil Specifications

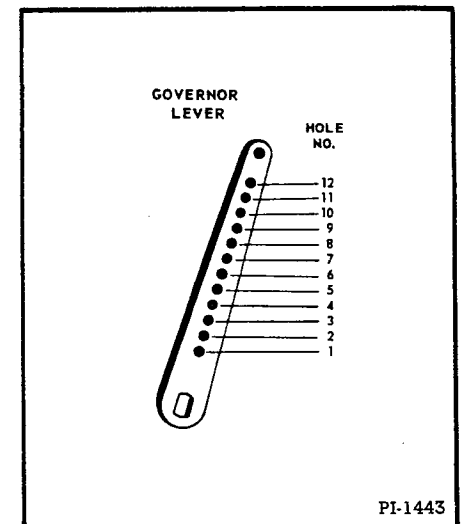
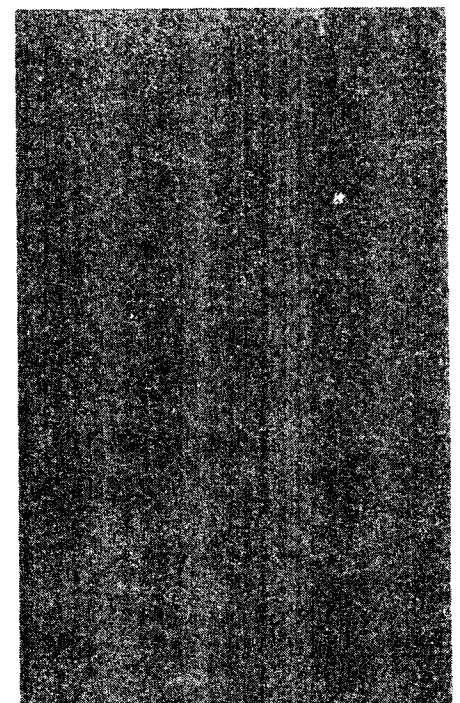

Fig. 176 Governor Lever



RETURNING STORED ENGINE TO SERVICE

Drain condensation from the engine.

Fill the crankcase to the proper level with the proper grade of engine oil.

Check the spark plugs.

Refuel the engine.

CARBURETOR ADJUSTMENT

The main metering jet in the carburetor is of the fixed type. It requires no adjustment. The idle needle should be adjusted for best low-speed operation, while the carburetor throttle is closed by hand. Turning the needle in closer to its seat results in a richer mixture. Turning the needle out away from its seat results in a leaner mixture (Figure 177).

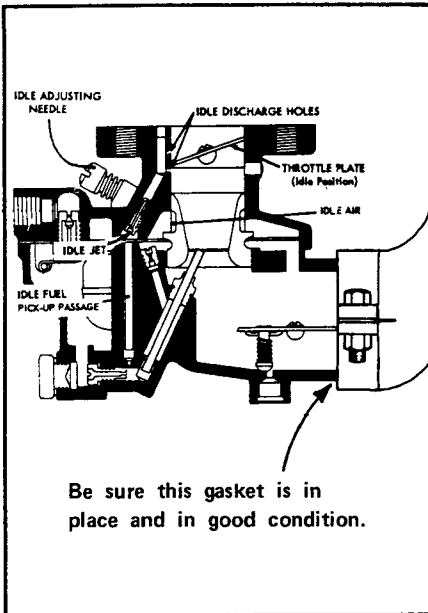

Fig. 177 Carburetor Adjustment

CARBURETOR RECONDITIONING (Figure 178)

To remove the throttle body assembly:

1. Remove the four bowl to body assembly screws (Item 35) and lockwashers using a screw driver.
2. Raise the throttle body slightly and separate the bowl to body gasket (Item 17) from the fuel bowl assembly, then lift off the throttle body carefully to avoid damage to the floats.

To disassemble the throttle body:

1. Press against the end of the float axle (Item 16) at the slotted side of the hinge bracket to force the axle through the hinge bracket. Use a small screwdriver. Then remove the float axle from the opposite side. Remove the float assembly (Item 15) and fuel valve needle.
2. Remove the bowl to body gasket (Item 17) from the machined surface of the throttle body (Item 8), then remove the venturi (Item 18).
3. Remove the fuel valve seat (Item 14) with its fiber washer (Item 13).
4. Remove the idle adjusting needle (Item 10) and friction spring (Item 9) from the side of the throttle body.

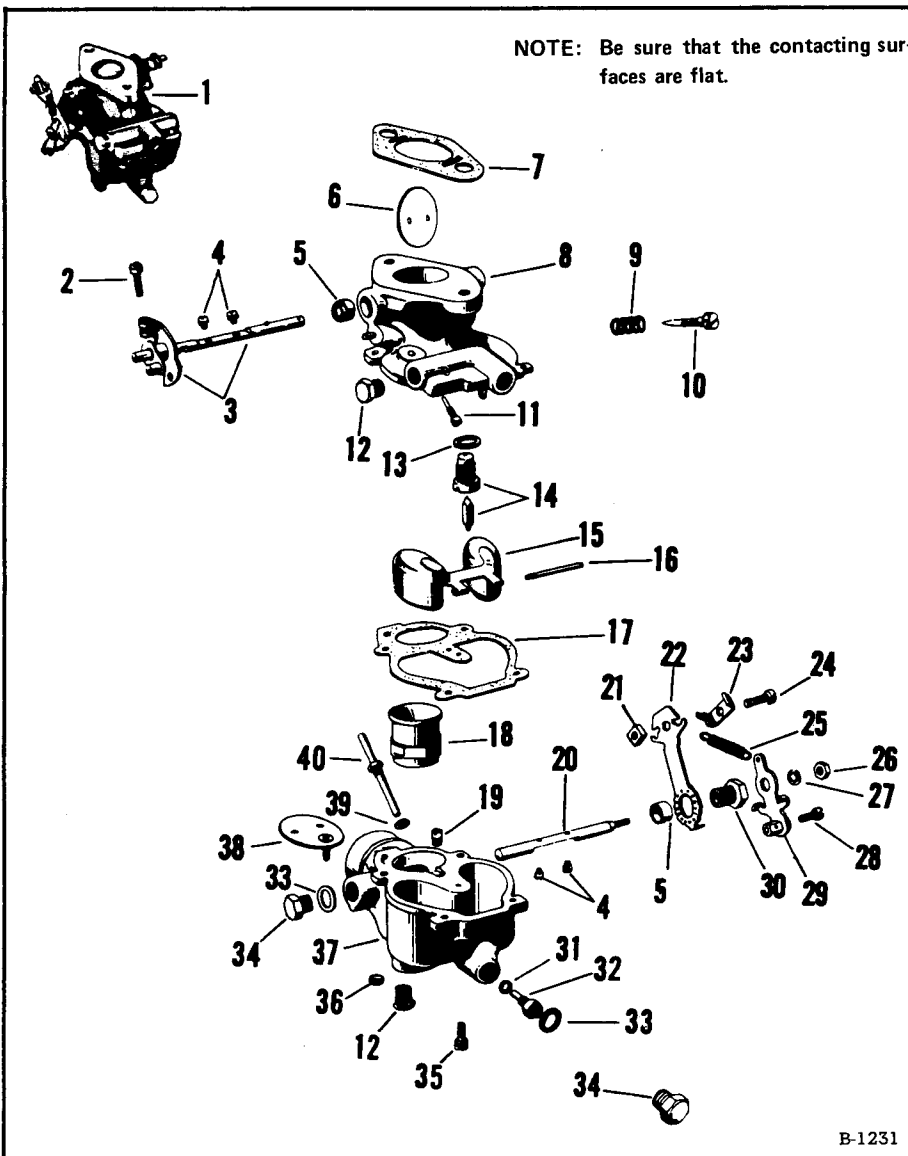

B-1231

Fig. 178 Carburetor Breakdown

5. Remove the idle jet (Item 11) from the passage in the machined surface of the throttle body, near the fuel valve seat. Use a small screw driver.
6. Back out the throttle stop screw (Item 2) flush with the end of the lever (Item 3). Close the throttle and mark the levers and throttle body as a guide to correct assembly of parts.

NOTE: Do not remove the throttle plate, throttle shaft and lever assembly, throttle packings and retainers from the throttle body unless the shaft is bent or other components of the assembly are damaged.

7. File off the riveted or peened ends of the throttle plate screws (Item 4) flush with the throttle shaft. Use care not to damage the throttle plate or throttle bore.
8. Remove the throttle plate screws, throttle plate (Item 6) and throttle shaft and lever assembly (Item 3).
9. To remove the throttle shaft packing and retainer (Item 5), screw a 5/16" - 24 thread tap into the packing retainer until firmly seated. Insert a long punch or rod through the opposite shaft hole and drive out the retainer and packing. Repeat for the other side.
10. Remove the fuel inlet plug (Item 12) and screen (if used).

To disassemble the fuel bowl:

1. Remove the 1/2" plug (Item 34) from the bottom of the fuel bowl. Remove the fiber washer (Item 33).
2. Remove the fuel bowl drain plug (Item 12) from the bottom of the bowl.
3. Remove the main jet (Item 32) and fiber washer (Item 31) from the threaded passage near the bottom of the fuel bowl.
4. Remove the main discharge jet (Item 40) with its fiber washer (Item 39) from the center of the fuel bowl casting.
5. Remove the well vent jet (Item 19) from the machined surface of the fuel bowl. Use a small screwdriver.
6. Mark the choke bracket (Item 22), choke lever (Item 29) and air intake body as a guide to correct assembly.
7. Remove the choke lever spring (Item 25). Close the choke and remove the choke plate screws (Item 4) and choke plate (Item 38). Note the position of the poppet spring in the air intake.
8. Remove the choke shaft nut (Item 26) and lockwasher (Item 27). Remove the choke lever (Item 29).
9. Remove the bracket assembly screw (Item 30) using a 1/2" open end wrench. Remove the choke bracket (Item 22).
10. Remove the choke shaft hole plug (Item 34) and fiber washer (Item 33) using a 1/2" open end wrench.

NOTE: For removal of choke shaft packings and retainers, refer to step 9 under "disassembling the throttle body."

Thoroughly clean all metal parts, using a special carburetor parts cleaner and rinse in solvent. Blow out all passages and channels in the castings with compressed air. Reverse the air flow through each passage to insure the removal of all dirt particles.

WARNING

Never use a wire or drill to clean out the jets.

Inspect all parts and replace any that are damaged or worn. Always use a repair kit. For the correct repair kit to use, see your Bobcat Parts Book.

To Reassemble the fuel bowl and air intake assembly:

1. Insert the choke shaft packing and retainer using a bushing driver. Be careful. Lightly drive the retainer into the body until flush with the machined surface. Repeat for opposite side.
2. Carefully guide the choke shaft (Item 20), through the packings and retainers, into position in the air intake body. Insert the choke plate (Item 38) into the cut out of the choke shaft. Make sure the choke plate poppet valve is in the same position as when it was disassembled. Install the choke plate screws using a small screwdriver.
3. Install the choke shaft hole plug (Item 34) with its fiber washer (Item 33) and tighten with a 1/2" open end wrench.
4. Place the choke shaft bracket (Item 22) on the assembly screw (Item 30) and attach the bracket to the air intake in the same position as when removed. Tighten the screw using a 1/2" wrench.
5. Assemble the choke lever (Item 29) onto the choke shaft in the same position as when removed, using the lockwasher (Item 27) and nut (Item 26). Tighten the nut.
6. Attach the choke lever spring (Item 25) to the choke lever and choke bracket.
7. Place the fiber washer (Item 39) over the threads of the main discharge jet (Item 40). Install the main discharge jet in the bowl assembly and tighten firmly.
8. Install the well vent jet (Item 19) in the bowl assembly. Tighten, using a small screwdriver.
9. Place the fiber washer (Item 31) on the main jet (Item 32) and install the main jet in the threaded hole near the bottom of the bowl.
10. Install the hex plug (Item 34) and gasket (Item 33) and tighten securely.

To reassemble the throttle body assembly:

1. Insert the throttle shaft packing and retainer using a bushing driver. Be careful. Lightly drive the retainer into the body until flush with the machined surface. Repeat for other side.

2. Insert the throttle shaft and lever assembly (Item 3) into the throttle body. Rotate the shaft to wide open position.
3. Insert the throttle plate (Item 6) and rotate to closed position. Hold the plate with your fingers and start the throttle plate screws (Item 4). Partially tighten them with a small screwdriver. Center the throttle plate in the throttle bore and tighten the screws.

NOTE: Make sure the leveled edges of the throttle plate fit the throttle bore when the throttle plate is closed.

4. Install the idle adjusting needle (Item 10) and friction spring (Item 9) into the threaded passage at the side of the throttle body. Turn the needle IN lightly against its seat. Then, back the needle OUT 1-1/4 turns as a preliminary adjustment.
5. Install the idle jet (Item 11) in its counter-bored passage and tighten, using a small screw driver.
6. Install the fuel inlet plug (Item 12) and screen (if used) in the threaded hole at the throttle body.
7. Invert the throttle body and install the fuel valve seat (Item 14) and fiber washer (Item 13).
8. Place a new throttle body to fuel bowl gasket (Item 17) on the machined surface of the fuel bowl cover. Install the fuel valve needle (Item 14) in its seat.
9. Place the float assembly (Item 15) in position with the float lever bushing in line with the holes in the hinge bracket. Install the float axle (Item 16).
10. To insure correct fuel level in the float chamber, check distance (Figure 179) from the top of the floats to the machined surface of the cover. To change the distance, use a long-nosed plier and bend the lever close to the float body.

WARNING

Do not bend, twist or apply pressure to the float bodies. When viewed from their free end, the float bodies must be centered and at right angles to the machined surface and must move freely on the float axle.

11. Insert the large opening end of the venturi (Item 18) into the throttle bore and position the venturi so the machined flat will be toward the fuel bowl when the bowl is assembled.

To assemble the fuel bowl to the throttle body:

1. Place the fuel bowl assembly on the throttle body assembly and align the holes in the bowl flange with the holes in the gasket and cover.
2. Install the four assembly screws (Item 35). Tighten them evenly and securely.
3. Hold the throttle lever in closed position and turn the throttle stop screw (Item 2) IN until it contacts the stop pin on the throttle body. Turn the screw IN 1-1/2 additional turns as a preliminary adjustment.

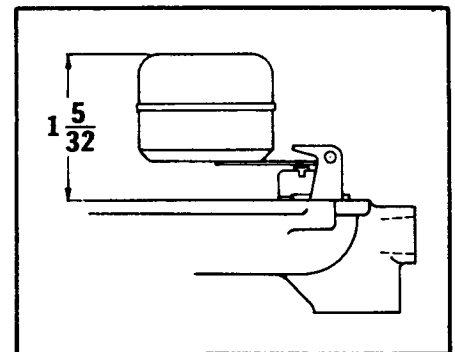
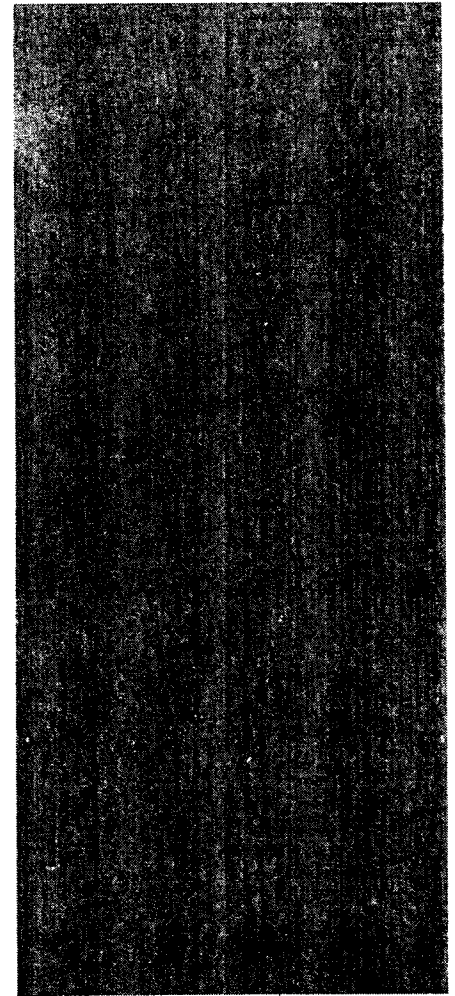
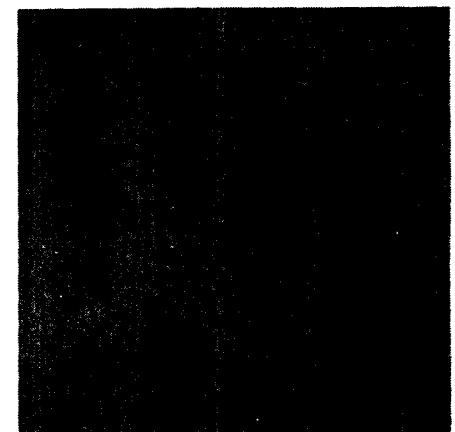

Fig. 179 Float Adjustment



LPG CARBURETOR SERVICE

To disassemble the carburetor:

1. Mark the throttle plate (Figure 180, Item 6) and main body for correct reassembly of the throttle plate. Remove the throttle plate screws (Item 5) and throttle plate.
2. Remove the throttle shaft and lever assembly (Item 10).
3. Remove the shaft seals (Item 3) and seal retainers (Item 2) from both sides of the main body.
4. Remove the venturi retaining screw (Item 11) and remove the venturi (Item 4) from the main body.
5. Remove the idle needle valve (Item 8) and idle needle valve spring (Item 9) from the main body.
6. Invert the carburetor, loosen the adjusting nut (Item 12) and remove the main adjusting screw (Item 13) with the adjusting nut.
7. Remove the screw plug (Item 21).

Fig. 180 LP Carburetor Breakdown

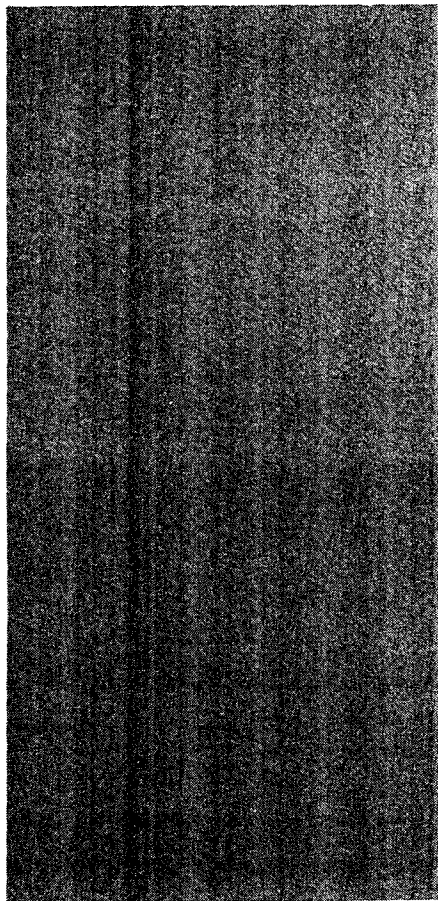

8. Mark the choke plate (Item 22) and air intake for correct reassembly of the choke plate. Remove the choke plate screws (Item 5) and choke plate. Remove the choke shaft nut (Item 16), choke lever (Item 15), choke shaft plug (Item 25) and choke shaft (Item 23).
9. Mark the location of the choke cable bracket (Item 19). Remove the choke bracket screw (Item 14).

Thoroughly clean all metal parts, using a special carburetor parts cleaner. Rinse in solvent. Blow out all passages and channels in the casting with compressed air. Reverse the air flow through each passage to insure the removal of all dirt particles.

WARNING

Never use a wire or drill to clean out the jets. Inspect all parts and replace any that are damaged or worn.

To reassemble the carburetor:

1. Attach the choke cable bracket (Item 19) to the main body using the bracket screw (Item 14) position as marked at time of disassembly and securely tighten the screw.
2. Insert the choke shaft (Item 23) and choke shaft hole plug (Item 25), attach the choke plate (Item 22) to the choke shaft. Position the choke plate as marked at time of disassembly. Leave the screws loose. Close the choke and align for best closing, then securely tighten the screws.

3. Attach the choke shaft lever (Item 15) to the choke shaft with its hex nut (Item 16). Position the lever as marked at time of disassembly. Securely tighten the nut.
4. With the carburetor inverted, replace the pipe plug (Item 21), adjustment screw locknut (Item 12) and adjustment screw (Item 13). Turn the adjustment screw in against its seat, then back it out two turns.
5. With the flange of the carburetor up, place the venturi (Item 4) into the throttle bore with the side hole in line with the screw hole in the main body and secure the venturi with its retaining screw (Item 11).
6. Place the throttle shaft seals (Item 3) into the seal retainers (Item 2) and assemble the seals and retainers into the counterbores of the main body.
7. Insert the throttle shaft and lever (Item 10) through the seals so the throttle stop screw is in contact with the stop pin when the throttle plate is in closed position. Attach the throttle plate (Item 6) to the shaft. Leave the screws loose. Align the throttle plate to the match marks. Close the throttle and align the plate for best closing. Tighten the screws.
8. Place the spring on the idle needle valve (Item 8) and install the idle needle and spring. Turn the needle valve in lightly against its seat. Back out the needle valve 1-1/4 turns.

VAPORIZER - PRIMARY REGULATOR SERVICE

The vaporizer (Figure 181) consists of a high pressure regulator and a vaporizer combined into a single unit. The high pressure regulator reduces LPG fuel tank pressure to a uniform outlet pressure. The vaporizer section vaporizes the liquid gas.

To disassemble the vaporizer:

Refer to Figure 182 for parts identification and follow the steps outlined below.

1. To remove the corrugated heat exchanger, clamp the vaporizer in a vise and remove the 1-1/4" brass nut (Item 24) with a thin wall socket wrench.
2. Remove the inlet orifice retainer (Item 11) and aluminum washer (Item 12) from the inlet bore.
3. Loosen the locknut (Item 3) on the adjusting screw (Item 2) and turn the screw all the way down to depress the inlet valve seat. The valve seat in its normal position interferes with the removal of the inlet orifice (Item 13).
4. Turn a 1/4" - 20 screw into the inlet orifice block and remove the block (item 13).

WARNING

The spring-loaded inlet valve seat must be fully depressed during this operation to prevent damage to both the seat and orifice block.

5. Remove the pressure adjusting screw (Item 2) and spring (Item 4).
6. Remove the six diaphragm cover screws (Item 5) and the diaphragm cover (Item 6).

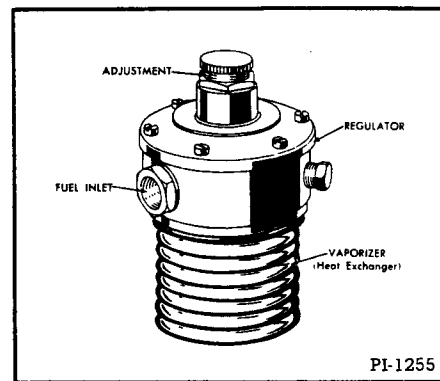

Fig. 181 Vaporizer-Primary Regulator

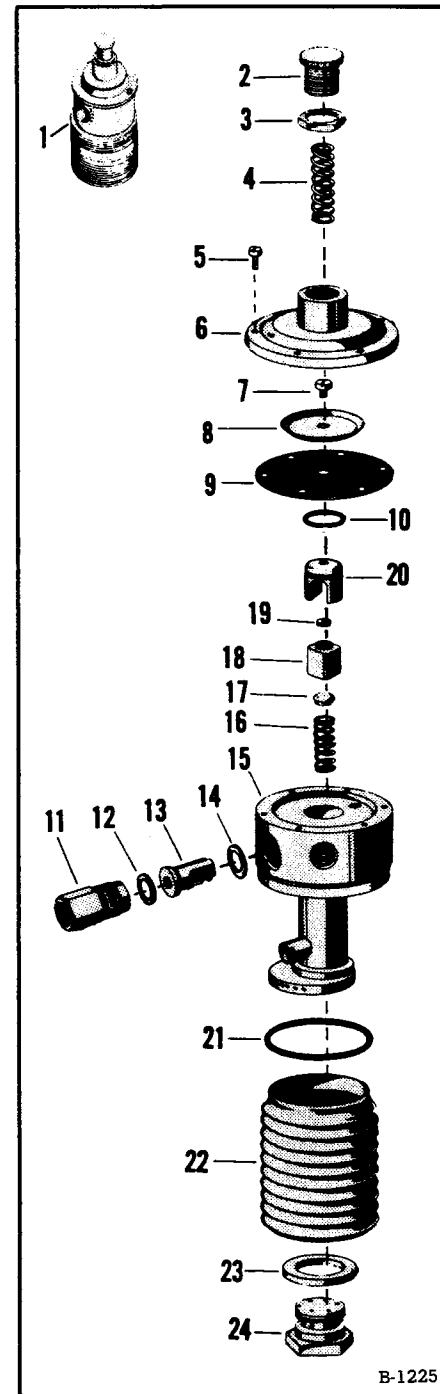

Fig. 182 Vaporizer Breakdown

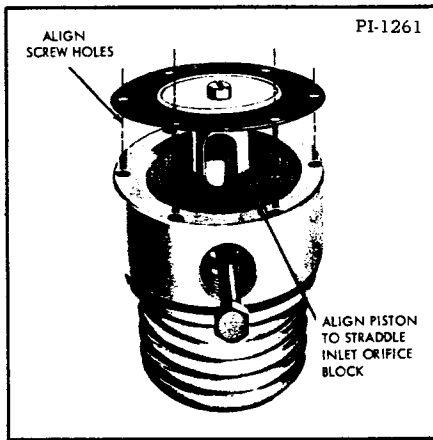

Fig. 183 Aligning Piston to Body

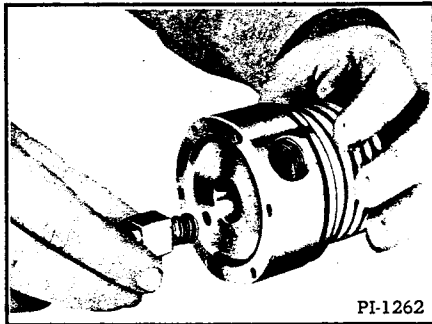
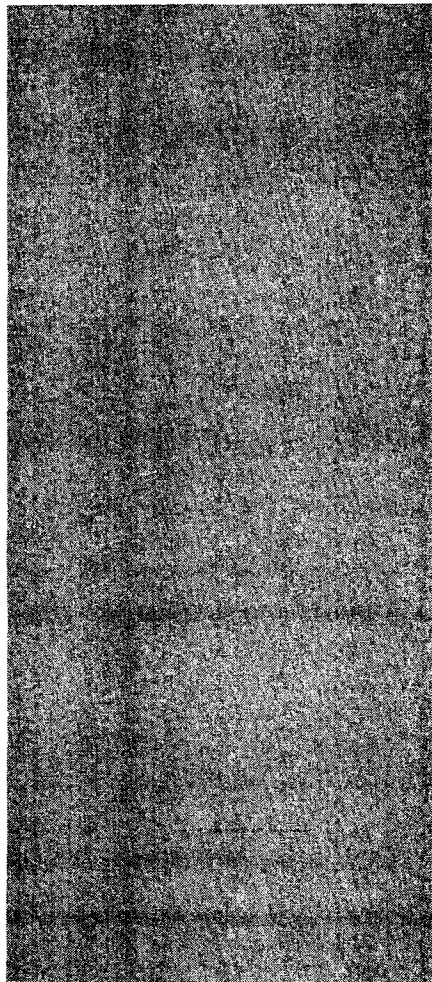

Fig. 184 Inserting Button and Spring



7. Lift the rubber diaphragm (Item 9) with the assembled piston from the bore. Remove the screw (Item 7) that secures the diaphragm and retainer to the piston and discard the diaphragm.
8. Invert the vaporizer assembly (Item 15) and remove the inlet valve seat and retainer, spring and valve cap (Items 16 thru 19).
9. Remove the large o-ring (Item 21) from its groove on the outside of the vaporizer housing.

To reassemble the vaporizer:

1. Position a new diaphragm (Item 9) over the piston (Item 20) and lay the retainer (flange up) on the diaphragm. Secure the parts with the diaphragm screw, but do not tighten at this time.
2. Check the condition of the inlet orifice (Item 13). If it is damaged at the orifice shoulder, replace this part.
3. Insert the inlet orifice block into its bore temporarily. This part has a slot and rides on a dowel pin located in the bore to prevent the part from being installed improperly.
4. Position the assembled diaphragm and piston into the bore (Figure 183) so that the piston straddles the inlet orifice block without rubbing against it.
5. Align the six screw holes of the diaphragm with the holes in the vaporizer head and tighten the diaphragm screw (Figure 183). Hold the diaphragm and retainer to keep them from moving when tightening the screw.
6. Remove the assembled diaphragm and piston and the inlet orifice block from their respective bores after proper alignment has been determined.
7. Check the inlet valve seat. If the neoprene disc is damaged or badly worn, replace the entire unit.
8. Place the button (Item 17) on the spring (Item 16) and insert the button end of the spring into the inlet valve seat (Item 18). Install these parts into the bore (Figure 184).
9. Install the assembled diaphragm and piston into the bore after replacing the o-ring on the piston. Coat the seal with a light film of oil for easier installation. Recheck the piston alignment by looking into the inlet orifice bore. The yoke of the piston should line up with the inlet orifice bore, and the six diaphragm holes should align with the holes in the top of the vaporizer.
10. Replace the cover over the diaphragm and secure it with the six cover screws. Place the adjustment screw spring (Item 4) into the bore through the top of the cover and install the adjusting screw and lock nut (Items 2 & 3).
11. Turn the adjusting screw all the way in to depress the inlet seat.
12. Install a new fiber washer on the inlet orifice block and insert the block in the bore using the slot as a guide. Remove the 1/4" - 20 screw from the assembled valve.
13. Place a new aluminum washer into the orifice bore. Thread the inlet orifice retainer into the bore and tighten. Install a new large o-ring into the groove on the outside of the vaporizer assembly.

14. Install a new o-ring on the heat exchanger and install the heat exchanger into the vaporizer head. Install the fiber washer and 1-1/4" brass nut. Tighten it securely using a thin wall socket.

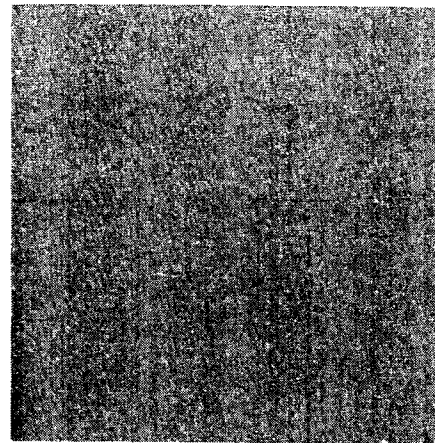

o adjust the vaporizer:

NOTE: The vaporizer assembly must be adjusted for a working pressure of not more than 12 PSI (Gauge Pressure) at each overhaul and at any time the pressure adjusting screw is moved.

1. Place the assembly in a vise or suitable clamp. Secure an air hose which will supply approximately 75 PSI to the inlet connection (Figure 185).
2. Connect a 0 to 30 or a 0 to 50 PSI pressure gauge to the outlet.
3. Back off the vapor adjusting screw until only one or two threads are holding the screw in the cover. Apply air pressure to the unit.
4. Turn the pressure adjusting screw in slowly until a reading not over 12 PSI shows on the gauge.

NOTE: To obtain an accurate gauge reading it may be necessary to unscrew the gauge partially to bleed off some of the air. Retighten the gauge and readjust for not over 12 PSI. If the gauge reading remains steady, the valve is not leaking. If the pressure reading creeps up, it indicates a leaking valve. It will be necessary to check for incorrect assembly, or replace valve parts as necessary.

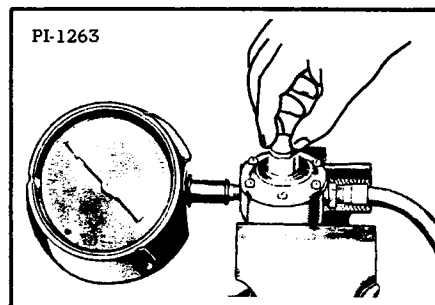
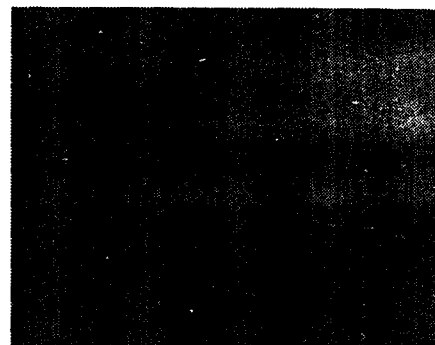

Fig. 185 Checking Working Pressure

5. With everything connected and adjusted as above, smear soap film over the vent hole in the diaphragm cover. Bubbles will appear if the diaphragm is leaking.
6. After the proper adjustment has been made, tighten the locknut on the pressure adjusting screw. Turn off the air pressure and disconnect the gauge and air line.



FINAL REGULATOR SERVICE

To disassemble the regulator: (Figure 186)

1. Remove both diaphragm assemblies (Item 2) by turning to the left, counterclockwise.
2. Remove the inlet orifice (Item 6).
3. Remove the regulator adjusting screw (Item 10).
4. Remove both leaf spring retaining screws (Item 8).
5. Remove the valve block and spring assembly (Item 5). Do not take this assembly apart.

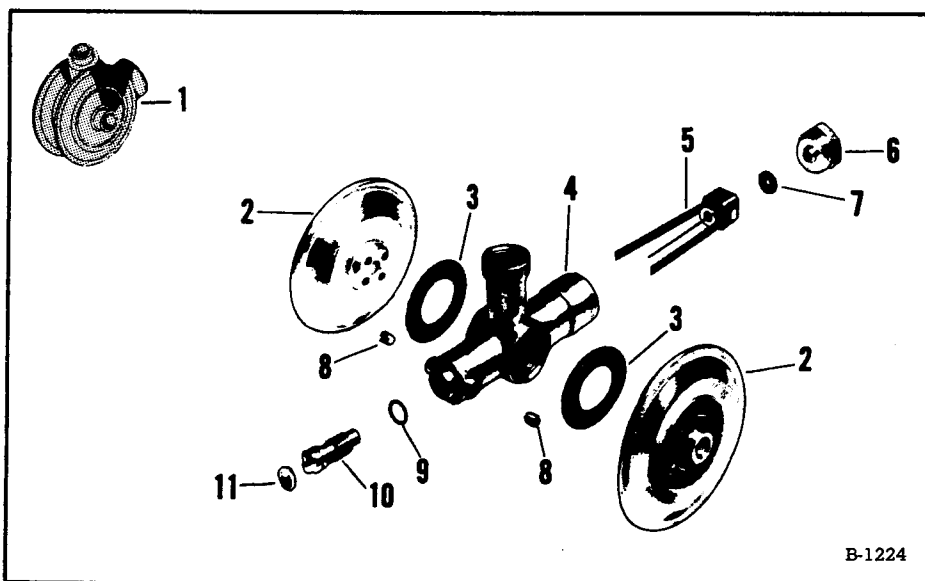

Fig. 186 Final Regulator Breakdown

B-1224

To clean the parts:

1. Clean all parts except the diaphragms with isopropyl alcohol. Clean the diaphragm covers by wiping with a cloth.

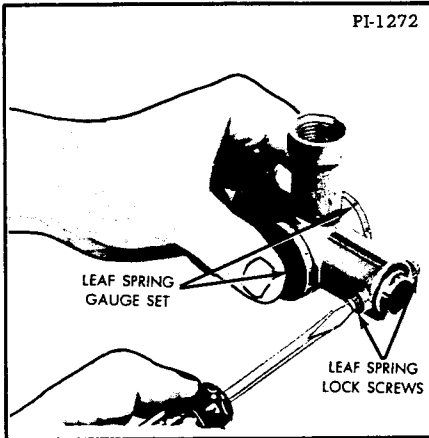
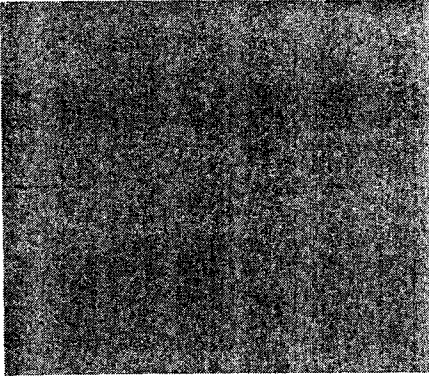
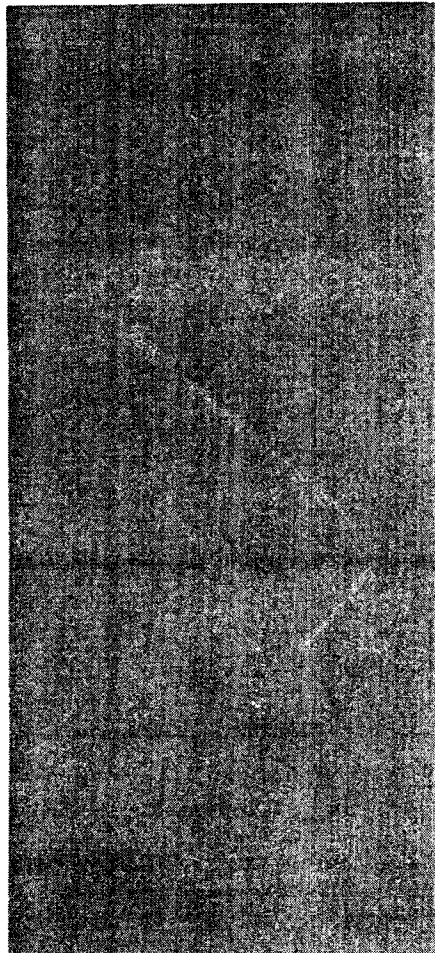

Fig. 187 Leaf Spring Gauge Set



2. Check the diaphragms for leaks. Remove the screen (or screens) from the vent opening in the diaphragm cover. Blow into the vent opening to extend the plunger, then seal the opening with your thumb. Press on the extended plunger. If the diaphragm is leaking, the plunger can be pressed in and will stay in. If resistance is felt, and the plunger springs back out upon being released, the diaphragm is not leaking.
3. Discard all worn or damaged parts.

To reassemble the regulator:

1. Install a new regulator valve seat (Item 7).
2. Insert the block, spring and valve assembly into the regulator body, making sure that the ends of the leaf springs enter their respective slots in the regulator body and are visible through the leaf spring retainer screw holes.
3. Install and tighten the inlet orifice (Item 6).
4. With the o-ring seal lightly lubricated, use finger pressure only to screw the regulator adjusting screw (Item 10) into the regulator body.

WARNING

If resistance is felt, it indicates that the round valve rod has not entered the hole in the regulator adjusting screw. In this event, remove the regulator adjusting screw and try again until the screw can be turned in by hand until the slotted head is almost flush with the body.

5. Seat the adjusting screw, lightly, with a screwdriver. It will need a final setting after assembly is complete.
6. Insert the leaf spring gauge set (Figure 187). Hold them in position while installing and tightening the leaf spring lock screws. Do not tighten them excessively.
7. Install and thoroughly tighten by hand both diaphragm assemblies. Use new cover-to-body gaskets (Item 3).

To test for a leaking valve:

1. Connect air or gas (at not over 12 PSI) to the regulator inlet.

NOTE: A previously adjusted vaporizer-primary regulator can be used as a source of air or gas at not over 12 PSI.

2. Smear a bubble film over the regulator outlet. A leaking regulator valve will be indicated by an expanding bubble at the outlet.
3. If the regulator valve leaks, disassemble the regulator and clean or replace valve parts as needed. Recheck for leaks.

Following is a procedure for setting the regulator valve to open at approximately 1/2" water vacuum:

1. Connect the air or gas (at not over 12 PSI) to the regulator inlet.
2. Seat the adjusting screw, lightly, with a screwdriver.

- Cover the regulator outlet with a bubble film. Slowly back out the regulator adjusting screw, by turning it counterclockwise, until the regulator just begins to leak. Point of leak will be indicated by a slowly expanding bubble at the regulator outlet.

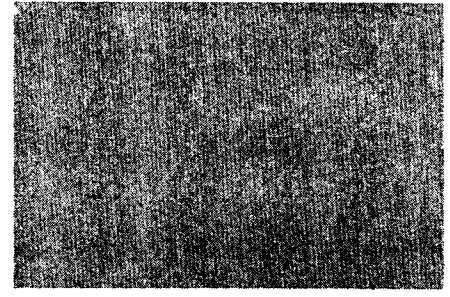

Find the point of leak and turn the regulator adjusting screw to the right (Clockwise) 3/4" to one turn from this position.

- After setting as indicated above, blow sharply into the diaphragm breather hole. This will open and reseat the inlet valve. Repeat this several times. Recheck the setting, following steps 3 and 4.

LP FUEL FILTER LOCK

To replace the filter element:

- Close the hand valve on the tank.
- Remove the filter assembly from the fuel tank.

NOTE: When you will be cleaning the filter, remove the entire solenoid section first to keep accumulated dirt and scale from entering the solenoid section.

Remove the solenoid by clamping the filter housing (Figure 188, Item 9) in a vise and carefully loosening the 5/8" hex brass body (Item 1). Carefully remove the solenoid section, including all items 1 through 7, 13 and 14.

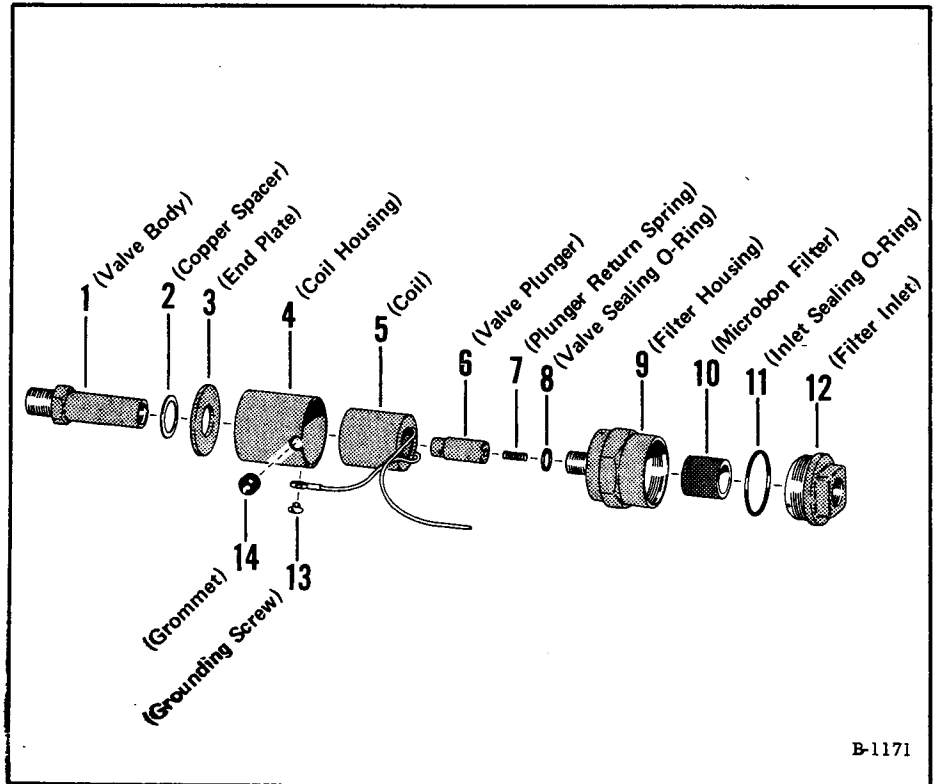
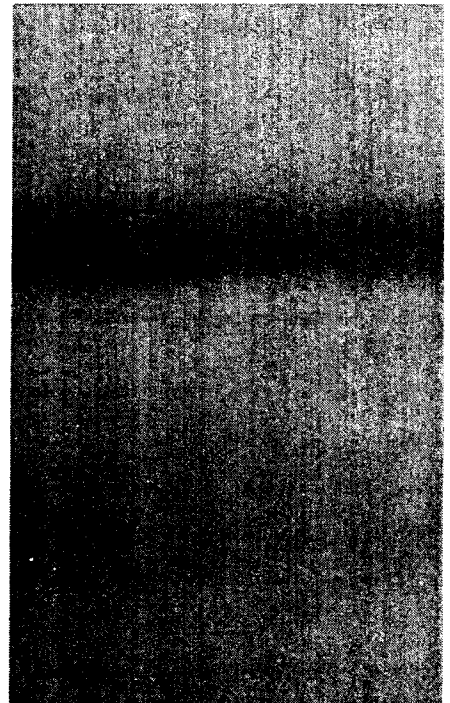

Fig. 188 LP Fuel Filter Lock

B-1171

- Hold the filter housing (Item 9) in a vise and unscrew the filter inlet (Item 12). It has a 3/4" square nut.
- Remove the filter element and clean any deposits out of the filter housing. Clean the element (Item 10) by blowing compressed air through it, from the inside out. Inspect the o-ring (Item 11) for any cuts or damage.
- Replace the cleaned or new filter element in the recess inside the filter element. Be sure it is seated. Lubricate the o-ring with a light mineral oil. Carefully turn the filter inlet completely in by hand, then torque it to 30 - 40 ft. lbs.
- Reassemble the solenoid section to the filter housing using a maximum of 18 ft. lbs. torque. Oil the o-ring (Item 8) on the filter housing to keep it from being damaged.



IGNITION TIMING

Remove the screen from the flywheel air intake opening by removing the screws holding the screen in place. This will expose the timing marks on the flywheel shroud, also the vane (on the flywheel) marked with an "X" and the letters "DC" (Figure 189). Now, follow this procedure:

- Connect the timing light in series with the No. 1 spark plug.

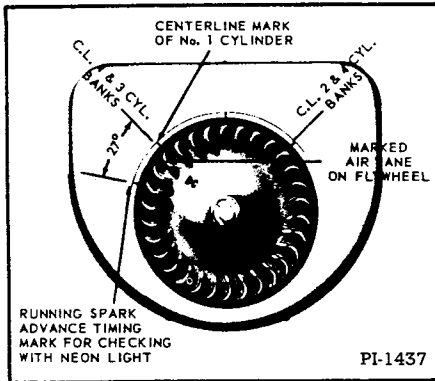

Fig. 189 Timing Marks

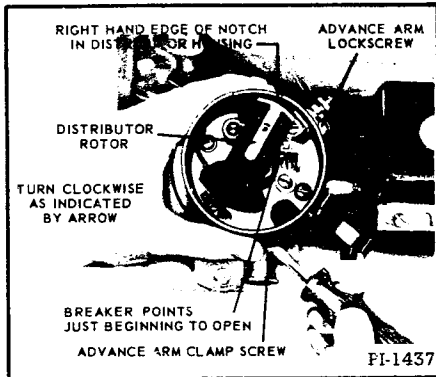

Fig. 190 Loosening Advance Arm Clamp

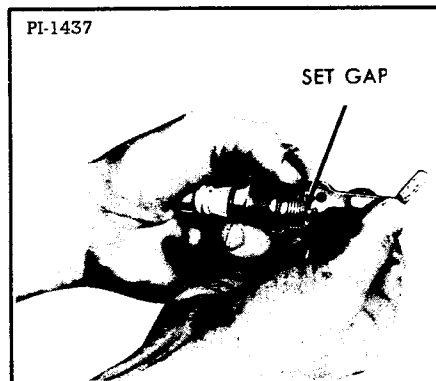
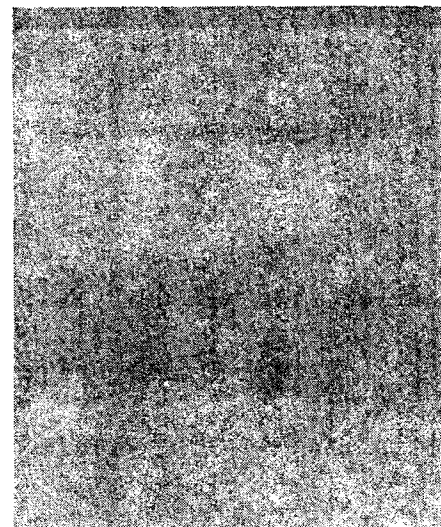

Fig. 191 Spark Plug Gap



2. Chalk or paint the end of the "X" marked vane on the flywheel white.
3. With the engine operating at 1800 RPM or over, allow the flash from the light to illuminate the whitened vane. At the time of the flash, the leading edge of the vane should line up with the running spark advance timing mark on the flywheel shroud (Figure 189). If it does not, loosen the advance arm clamp screw (Figure 190) and turn the distributor body slightly clockwise or counterclockwise until the advance timing mark and the white vane coincide. Be sure to tighten the advance arm clamp screw carefully.

WARNING

If the engine is running below 1800 RPM when timing, the automatic advance in the distributor will not be fully advanced and the inaccurate timing may cause serious damage to the engine when operating at high speeds.

4. Be sure to mount the flywheel screen after correct timing has been accomplished.

DISTRIBUTOR MAINTENANCE

The distributor breaker point gap should be .018 to .022 inches. To readjust the breaker point gap:

1. Turn the engine over by hand until the breaker arm rubbing block is on a high point of the cam.
2. Loosen the stationary contact locknut and screw the fixed contact in or out, until the correct gap is achieved.
3. Tighten the locknut and recheck the gap.

The distributor should be periodically lubricated and inspected for external conditions which could affect its operation.

Every 50 hours of operation, the oiler on the side of the distributor base should have 3 to 5 drops of medium engine oil added. Every 100 hours, apply 3 to 5 drops of medium engine oil to the felt in the top of the cam sleeve. Do not over-lubricate.

SPARK PLUG

The spark plug gap should be .030 inch. Plugs should be kept clean both inside and out (Figure 191). If the porcelain insulator is cracked, replace with a new plug of correct heat range. The spark plug thread is 18 millimeter. Be sure to use a good gasket under the spark plug. Tighten the spark plugs to 25 - 30 ft. lbs. torque.

HIGH TEMPERATURE SAFETY SWITCH

As a safety precaution, some engines have a high temperature safety switch mounted on the cylinder head near the No. 4 spark plug. The switch will automatically stop the engine when head temperatures rise beyond a safe degree.

The switch is set by the manufacturer to operate at the correct temperature. Consequently, the adjusting screw on the top of the switch should not be tampered with. If the cylinder head temperature at the spark plug reaches 570° F, the switch will automatically short out the distributor and stop the engine. A waiting period of about 7 minutes will be required before the switch has cooled off sufficiently to permit re-starting the engine. An overheated

ELECTRICAL CIRCUITRY (Rectifier-Regulator Module, One Unit)

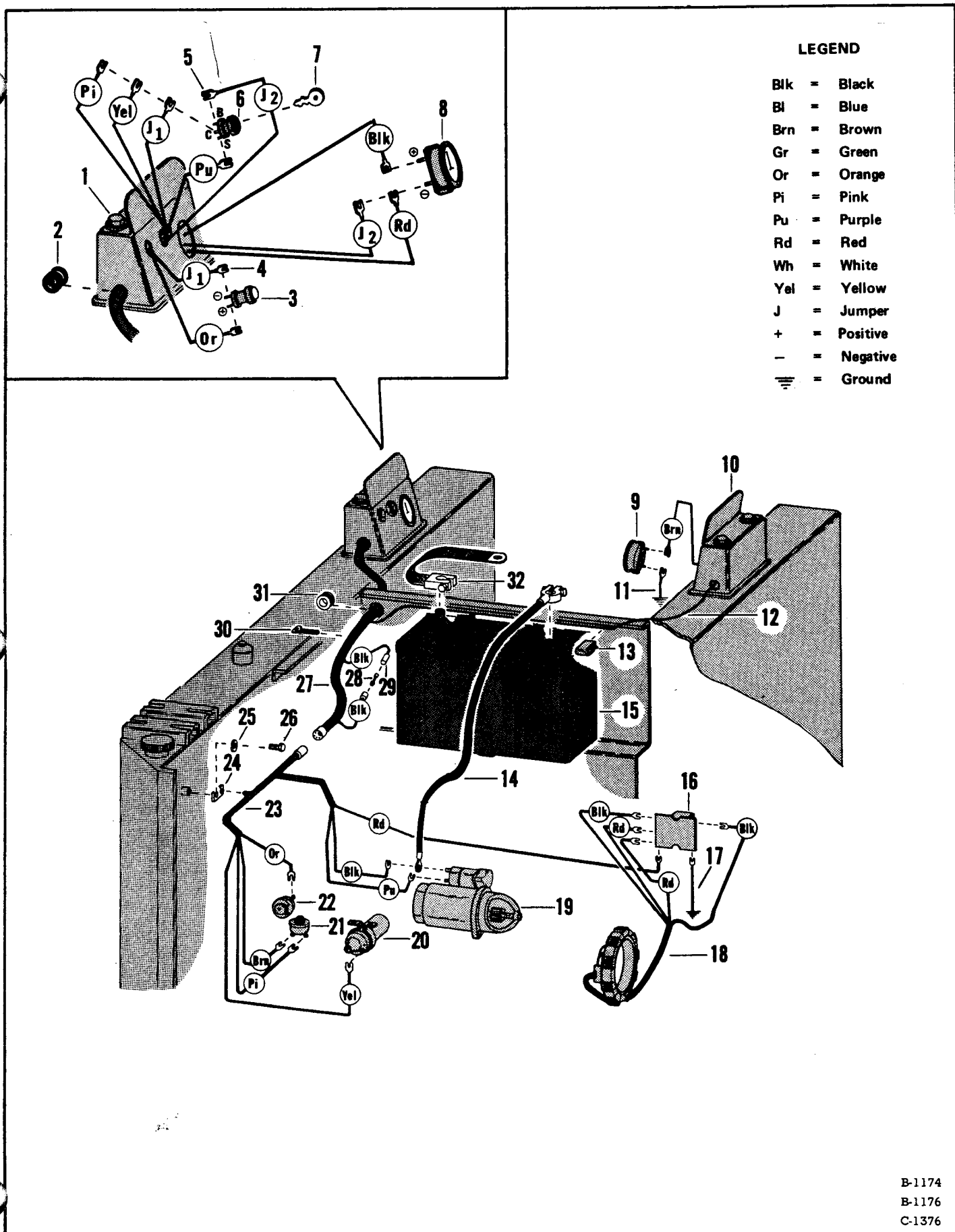

LEGEND

- Blk = Black
- Bl = Blue
- Brn = Brown
- Gr = Green
- Or = Orange
- Pi = Pink
- Pu = Purple
- Rd = Red
- Wh = White
- Yel = Yellow
- J = Jumper
- + = Positive
- = Negative
- ⏏ = Ground

Fig. 192 Electrical Circuitry (Rectifier-Regulator Module, One Unit)

B-1174
 B-1176
 C-1376

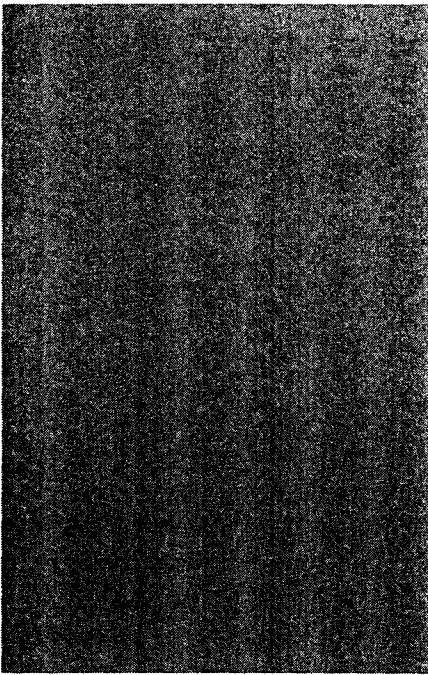

engine will score the cylinder walls, burn out connecting rod and crankshaft bearings and warp pistons and valves. The cause of the overheating condition will need to be remedied before re-starting the engine.

The wire from the high temperature safety switch must be connected to the same terminal on the distributor as the wire from the negative terminal of the ignition coil.

ALTERNATOR CHARGE SYSTEM

Rectifiers and stators on Kohler and Wisconsin engines are often needlessly replaced. The electrical system fuse is in the positive battery cable circuit, which carries both charge and draw amperage. A burned out fuse, corrosion in the fuse holder or an otherwise poor connection would create a no charge condition. Check the condition of the fuse and its contacts within the holder before assuming more serious alternator problems.

To check the stator:

Examine leads for broken wires or loose connections. If none is found, remove one red and one black lead from RECTIFIER-REGULATOR. Using an ohmmeter with R x 1 scale (Simpson Model 260, or similar meter with ohmmeter sensitivity of 20,000 ohms/volt) check continuity as follows: (See Chart at Left).

To check the Rectifier-Regulator:

Use the following procedure only when battery is not fully charged. Determine charge with hydrometer. It should not exceed 1225 (See Chart, Below Left).

METER PROBE CONNECTIONS	CORRECT METER VALUE	REPLACE STATOR
Red to Red	2.0 Ohms	∞ Indicates Short Circuit ∞ Indicates Open Circuit
Black to Black	0.1 Ohms	
Red to Black Red to Engine Black to Engine	∞	Any Reading Indicates Short Circuit

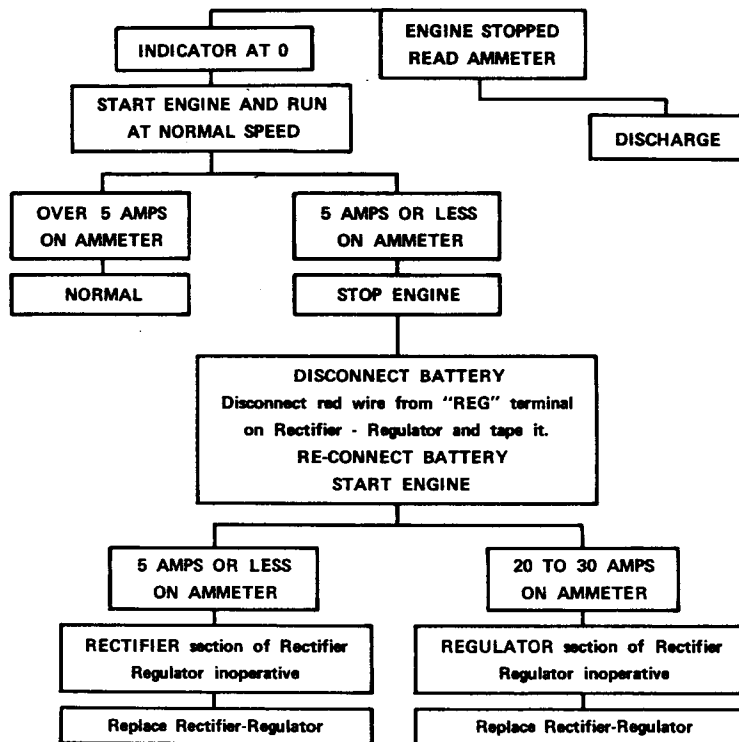

FOR EMERGENCY USE: Operate with "REG" wire disconnected and taped (to prevent short). After 1 hour, connect loose red wire to "AC" terminal. Charge will be 5 amps. After additional operation, if battery required more charge, remove red wire from "AC" and repeat.

Alternator wiring:

The metallic portions of the regulator are isolated from the mounting, and so the same regulator can be used in either a positive or negative ground system. WISCONSIN and KOHLER MOTORS, however, have adapted negative grounds as standard for all 12 volt generating circuits. All alternator-regulator wiring furnished by WISCONSIN and KOHLER will be for negative ground, and wired in accordance with the diagram in Figure 192. The white wire attached to the "BATNEG" terminal on the rectifier-regulator is grounded to the engine at a lug under one of the starter mounting bolts. This lug is also used for attaching the ground cable from the negative post of the battery to the engine.

All leads from rectifier-regulator must be 10 gauge wire and shall not exceed 10 feet in length. If longer leads are needed, 8 gauge wire must be used.

Installation of Equipment Solenoids:

1. Do not connect solenoid power lead to rectifier-regulator "BATNEG" terminal.
2. Make power lead connection at starter switch (as close to battery as possible) (Figure 192).
3. Add by-pass condenser at solenoid terminal. Use a 1 MFD condenser similar to that used for auto radio suppression.

Rectifier-Regulator Mounting:

The rectifier-regulator is insensitive to vibration and thus can be mounted to any type of support. Installation must, however, be in a vertical position. This chimney effect mounting tends to dissipate heat more efficiently. The four lead wires from the stator are 36" long, and if it is desired to mount the rectifier-regulator at some location other than the standard position on the engine shroud, approximately 15" of wire is available for this purpose.

Because an alternator differs from a D.C. generator, there are precautions to take:

1. Do not reverse battery connections.
2. Connect booster batteries properly; positive to positive and negative to negative.
3. Disconnect the regulator to battery lead if a fast charger is used.
4. Never use a fast charger to boost battery output.
5. Do not attempt to polarize the alternator. It needs no polarization.
6. Do not ground output wires or field wires between the alternator and regulator.
7. When arc welding on machine, disconnect battery ground lead.
8. Do not operate engine with battery disconnected from system.

Flywheel Alternator System:

The alternator system used on the K662 Kohler and VF4D Wisconsin engines provides electrical power to charge the 12 volt battery and also furnishes power for a lighting circuit. This system has the following basic components:

1. Permanent Field Magnet Ring
2. Alternator Stator
3. Full Wave Rectifier
4. Voltage Regulator

A brief description of each of these components will aid in explaining the operation of this system:

1. Permanent Magnet Ring. This assembly consists of 12 permanent magnets imbedded in a die cast ring. The ring is affixed to the inside rim of the flywheel, then machined to obtain the proper air gap between it and the stator.

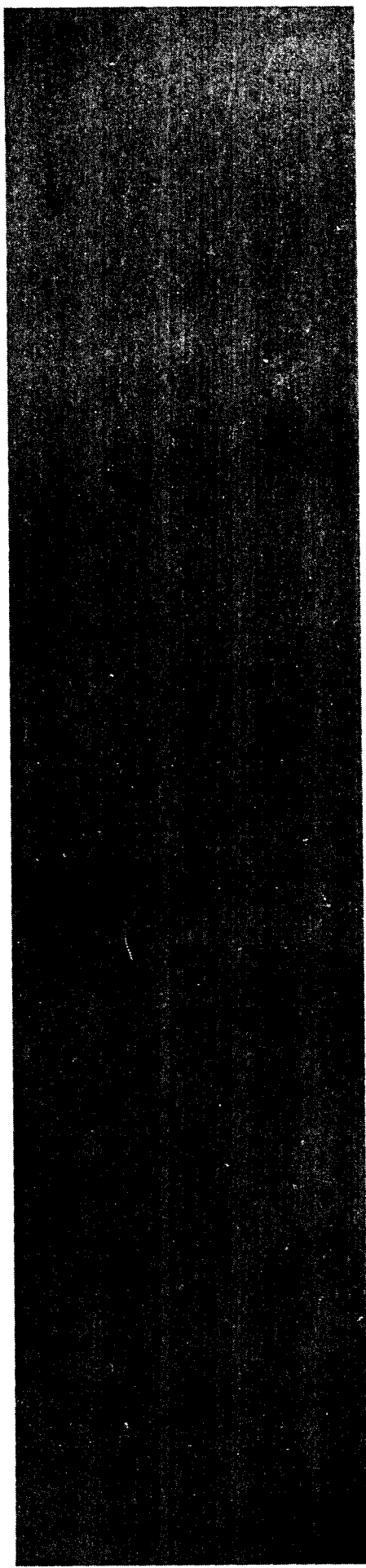

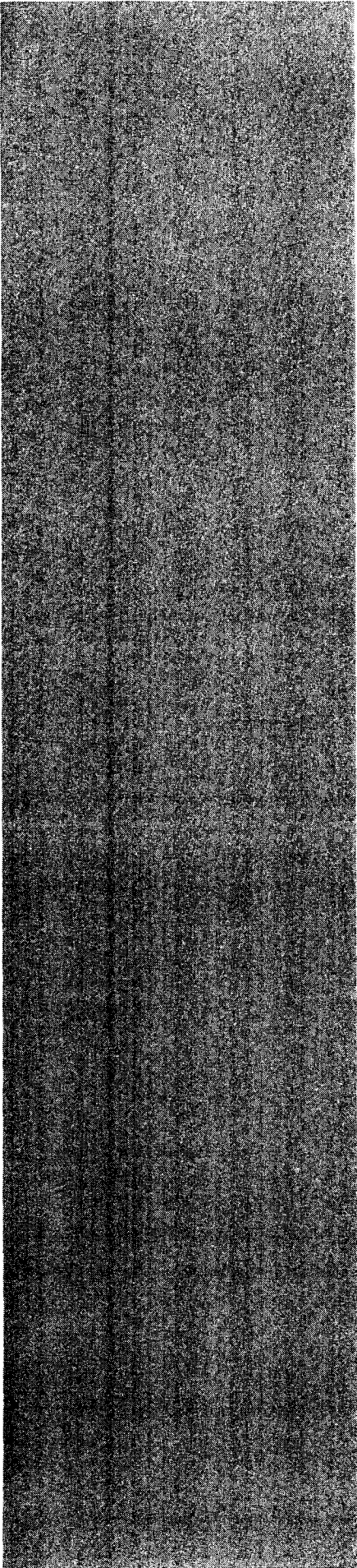
- 
2. **Alternator Stator.** The stator is assembled in stationary position on the gear housing of the engine. This assembly consists of twelve coils. Each of the coils contain a primary or load winding and a secondary winding which acts as a regulator winding.
 3. **Full Wave Rectifier.** A rectifier is a device used to convert alternating current to direct current. The rectifier used does this through the use of half-wave diodes. These are electronic devices that allow current to flow in one direction but block flow in opposite direction. Since alternating current continually alternates from positive to negative direction, the use of both positive and negative diodes in a full wave bridge arrangement rectifier AC into a smooth flow of direct current. Since heat is necessary to operation of this rectifier, the heat dissipating fins must be mounted in an upright position for maximum cooling.
 4. **Voltage Regulator.** This is a solid state regulator that uses resistors, a silicon controlled rectifier (SCR) and a Zener voltage sensor. The use of solid state electronic devices eliminates the necessity of mechanically operated contacts and thus failure due to vibratory damage or fatigue. The voltage regulating device is mounted on the front of the full wave rectifier.
 5. **Function of the Alternator System.** As the permanent field magnet ring rotates around the stator, an alternating current is induced in the primary or load winding of the stator. The current produced is approximately 35 amperes. This AC current flows to the Full Wave Rectifier where it is rectified to direct current which then flows to the battery and lighting circuit.

The regulator acts to limit the battery charge rate by controlling battery voltage. When the Zener diode in the voltage regulator senses capacity charging, it switches and allows current to flow into the secondary winding of the stator. As current flow increases in the secondary, it causes the current flowing in the primary winding to decrease. When no current flows in the secondary, maximum current flows in the primary, likewise, when no power is needed in the load winding, maximum current flows in the regulator winding.

Servicing the Alternator System:

The serviceman will find that the syncro alternator differs somewhat from the conventional alternator or generator. The conventional alternator must derive output current through the use of a field current from the battery, whereas the syncro alternator has current available at all times and uses it only to regulate voltage. This is accomplished through the use of an electronic switch know as a silicon controlled rectifier. When the SCR conducts regulating current through the regulating winding, it actually limits or turns off the current flow in the load winding as the current demand varies.

1. **Installation of Rectifier-Regulator Assembly.** Assembly must be installed in a vertical position, creating a chimney effect which tends to dissipate heat more efficiently.

Do NOT install resistors, fuses or lead wire smaller than No. 10 AWG in connections from the battery to the bridge rectifier assembly.

2. **Service Procedure.** It is desirable to check an improperly operating alternator with a volt ohmmeter. Listed below are various alternator problems with a detailed analysis of best procedure to follow:
 - A. First examine lead wires for loose or broken connections at the rectifier-regulator. Opens or ground may be detected in the stator through the use of the R x 1 scale of your ohmmeter. Remove (4) input leads from rectifier-regulator. Connect meter test leads to read lead wires to check continuity. Approximately 2.0 ohms resistance should be read on your ohmmeter.

Next connect meter to black lead wires. Approximately 0.1 ohms should be your reading here. There should be no ground connection from either winding, nor should there be a connection between windings. If a connection exists between the two windings or to ground, stator assembly should be replaced.

- B. Full Wave Bridge Rectifier. Examine each of (4) diodes for breakdown by connecting ohmmeter R x 1 scale from AC input connection to positive plate, then move lead to negative plate alternately. Meter should read approximately 10 ohms in proper polarity. A shorted diode will indicate no resistance and would cause a short circuit through the load winding when in operation. AC open diode would read infinite resistance and would also indicate that replacement is necessary.
- C. Regulator Assembly. The regulator assembly contains (2) semiconductors, a silicon controlled rectifier, which is the electronic switch for the control winding, and a zener diode which is the battery voltage sensing device, turning the SCR on when the battery voltage at the predetermined level. To adjust voltage, remove (2) screws from regulator cover, lift cover off, connect voltmeter to battery terminals. Be sure battery load is less than alternator output so that unit is regulating. With alternator running at approximately one-half speed, adjust potentiometer to desired voltage.
- D. Battery Voltage Too Low. Follow previous procedure, turning variable resistor clockwise.
- E. Full Charge Will Not Regulate. Check for broken lead wires at connection to regulator plates. To be sure regulator winding operates properly, connect (2) red leads together. Start engine. A maximum of 4 amperes charge should be noted. This would indicate stator winding is satisfactory. Regulator should be replaced.
- F. Battery Voltage Too High. Remove regulator cover. Connect voltmeter to battery terminals. Start engine. With a small screwdriver or suitable blade adjust variable resistor counterclockwise until proper voltage is obtained. Replace cover.

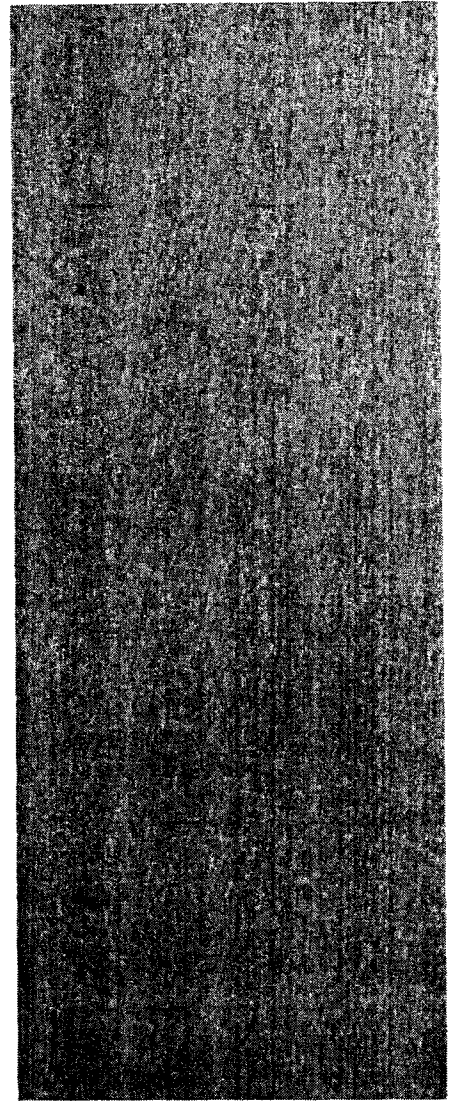

TURN CLOCKWISE TO INCREASE.

TURN COUNTERCLOCKWISE TO REDUCE.

- G. No Charge. If alternator does not charge when load is applied to battery, shut off engine. Disconnect regulator lead (red) from regulator terminal. Be sure lead is taped or isolated from conducting engine parts. Once again start engine. Alternator should charge to full output. If not, assembly should be replaced.

Recent rectifiers furnished by engine manufacturers do not have the voltage adjustment feature. This was eliminated to improve the service life of the unit.

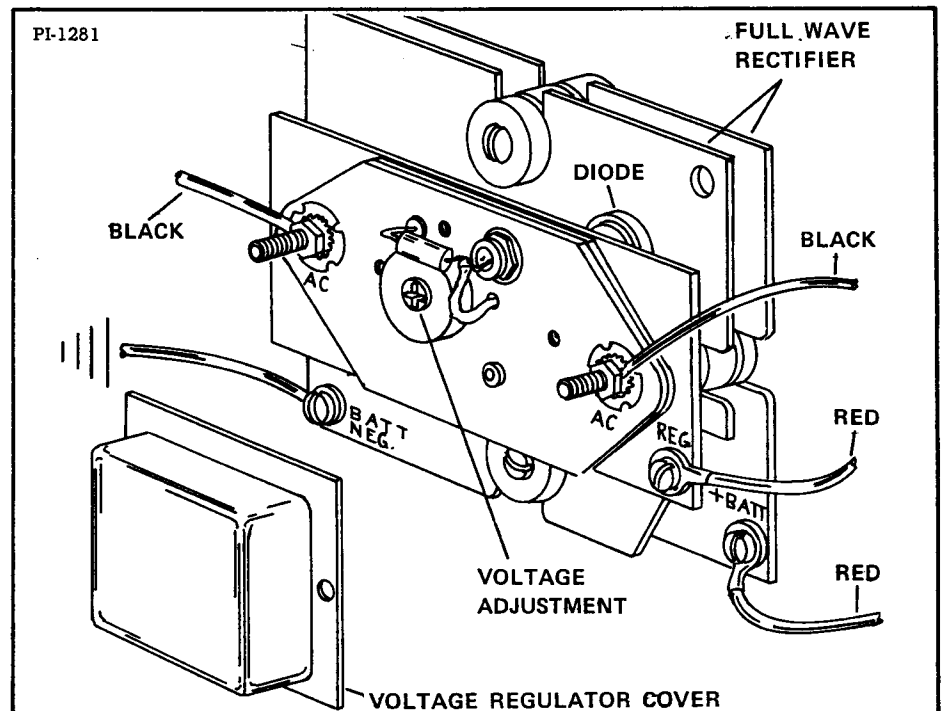

Fig. 193 Voltage Adjustment

ELECTRICAL CIRCUITRY (Rectifier-Regulator Module, Two Unit)

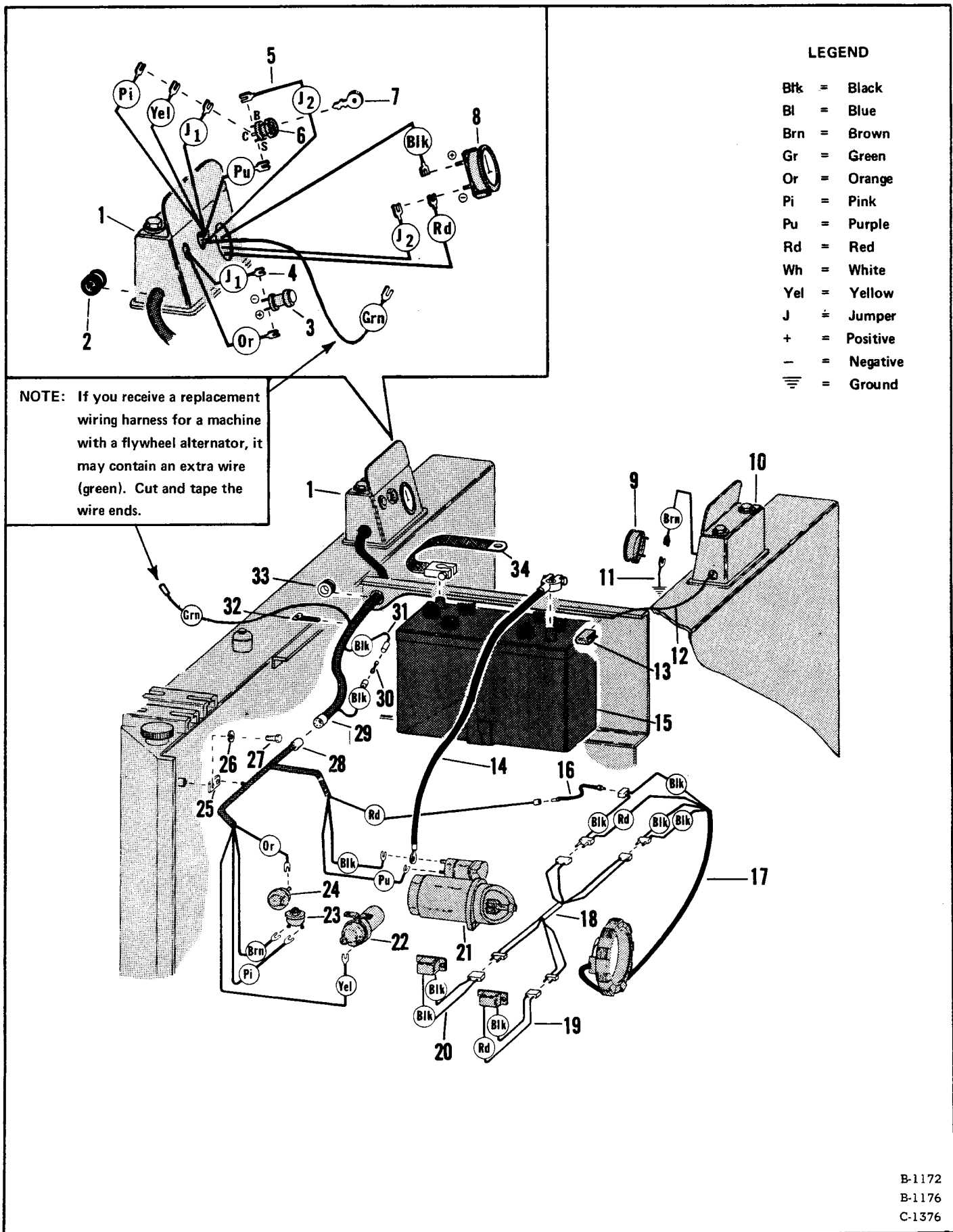

Fig. 194 Electrical Circuitry (Rectifier-Regulator Module, Two Unit)

NOTE: Read this completely before attempting any checks.

Current Wisconsin engines have the rectifier and regulator modules mounted to the shrouding at the rear of the engine. On some engines the rectifier and regulator modules were mounted behind the distributor. They are hard to check and service. You may want to move the modules out onto the shrouding. To do this:

1. Disconnect the connectors by squeezing the outer ends of the receptacles and pulling apart.
2. Remove the modules from their position behind the distributor.
3. Mount the modules on the shroud at the rear of the engine. Mount the rectifier slightly higher and to the left of the regulator module.

NOTE: The rectifier and regulator modules are grounded to the engine frame. You will need to remove paint from the shroud to get a metal to metal contact between the base of the modules and the shrouding. Do not mount the modules anywhere other than on the engine.

4. Use a jumper harness (Figure 195 Item 1) to connect the stator leads to the rectifier and regulator modules. The fool-proof type connectors prevent incorrect wiring.

CHECKING THE RECTIFIER AND REGULATOR

All ohmmeter readings are to be made on the R1 scale.

Examine the leads for broken or frayed wires, or loose connections. If none are found, disconnect the battery and uncouple the rectifier and regulator modules from the jumper harness. Make sure the bases of the modules are making good contact with the engine shroud.

Use an ohmmeter to check whether the rectifier and regulator are defective. All the checks can be completed without removing anything from the machine. If a meter connection is shown going to ground, it means engine ground. Be sure you have a good ground connection.

NOTE: If your ohmmeter does not give you the readings shown in Figures 196 thru 205, reverse the leads going into your meter. If the readings still differ from the readings listed, replace the part tested.

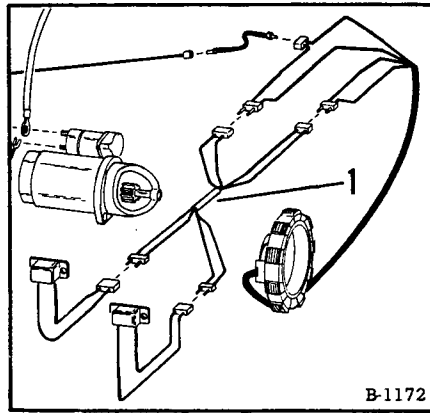

Fig. 195 Wiring Diagram

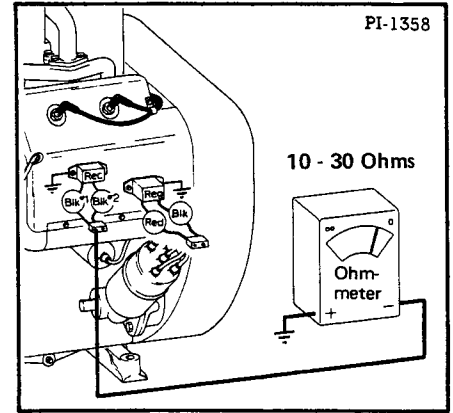

Fig. 196 Rectifier Check #1

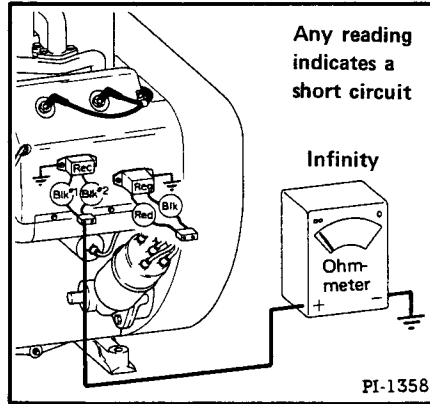

Fig. 197 Rectifier Check #2

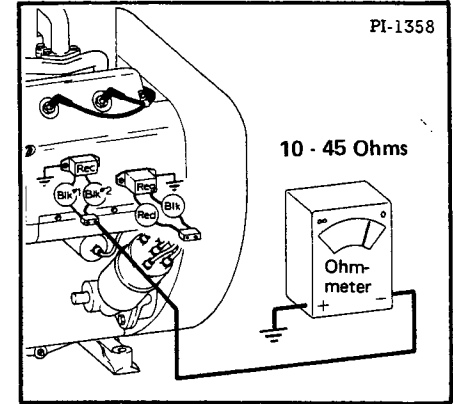

Fig. 198 Rectifier Check #3

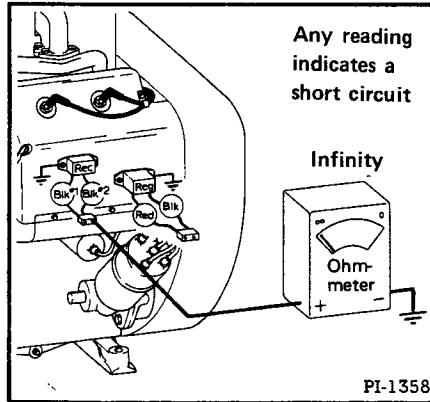

Fig. 199 Rectifier Check #4

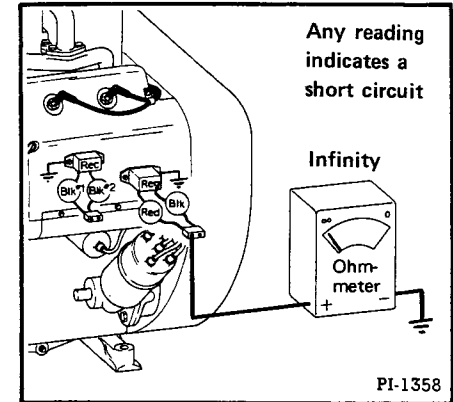

Fig. 200 Regulator Check #1

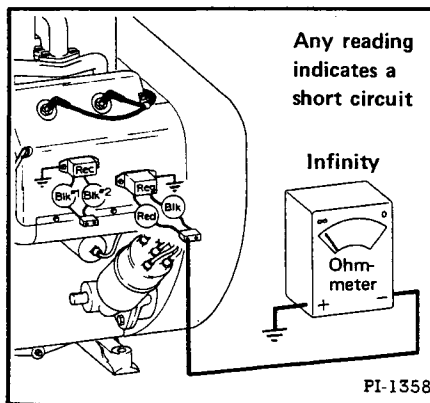

Fig. 201 Regulator Check #2

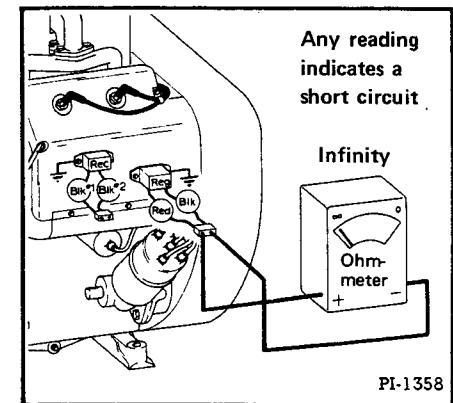

Fig. 202 Regulator Check #3

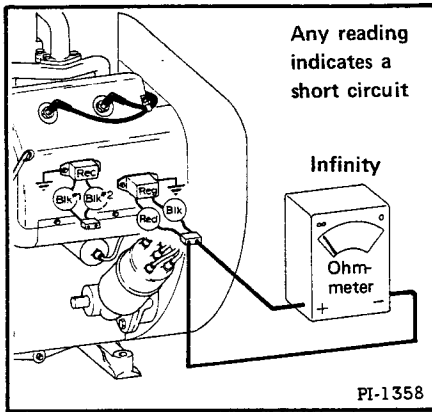

Fig. 203 Regulator Check # 4

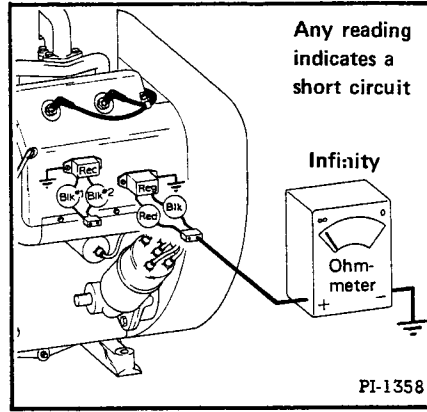

Fig. 204 Regulator Check #5

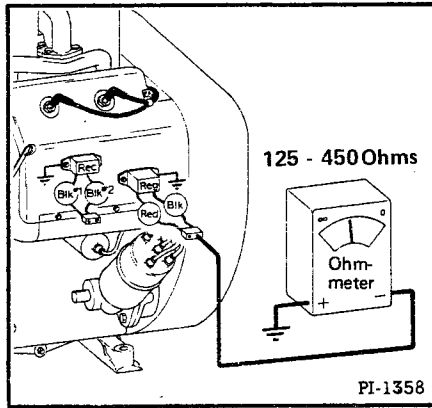

Fig. 205 Regulator Check #6

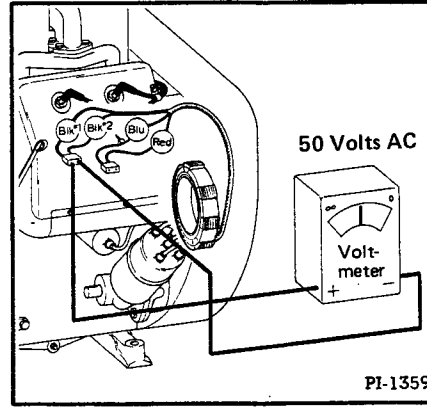

Fig. 206 Stator Check #1

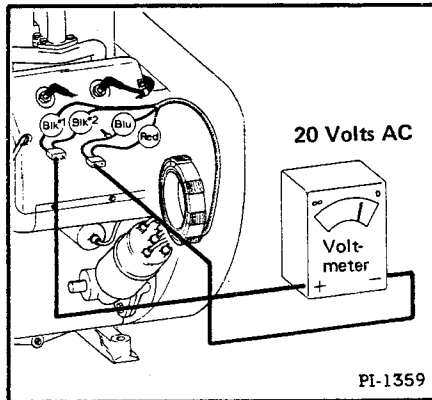

Fig. 207 Stator Check #2

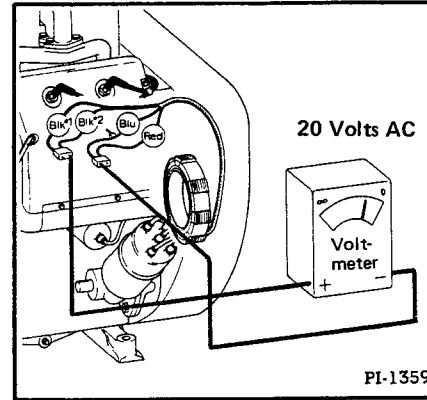

Fig. 208 Stator Check #3

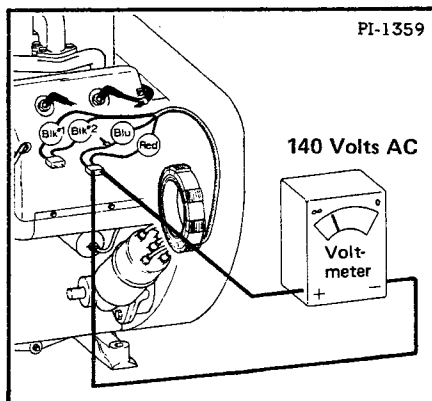

Fig. 209 Stator Check #4

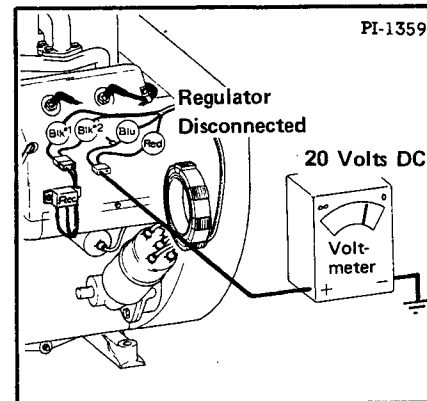

Fig. 210 Stator Check #5

STATOR CHECKS

Use a test light (or continuity tester) to check for shorts from the stator leads to ground. The test light will indicate any shorts by lighting the bulb. If the bulb indicates there is a short, the stator will need to be replaced. If the bulb does not light when checking any of the stator leads to ground, check to make sure there is continuity (bulb lights) between each combination of two stator leads. If you have continuity, go on to the voltage check. Use a voltmeter to check the stator. Run the engine at full throttle when taking these readings.

NOTE: The voltmeter readings may differ from the ones shown in Figures 206 thru 210. The readings given are meant as a guide.

If the stator is bad the readings will differ greatly from the readings shown. They will be lower readings.

NOTE: If the engine is not run at full RPM the readings may vary.

If all checks are made and all readings are acceptable, but the battery doesn't charge, there must be a bad connection in the wiring harness or the battery terminal.

NOTE: The blue wire, as referred to in these tests, is the wire next to the red wire. It is blue coming off the stator, but may be any color next to the connector.

ELECTRICAL CIRCUITRY (Delco Alternator)

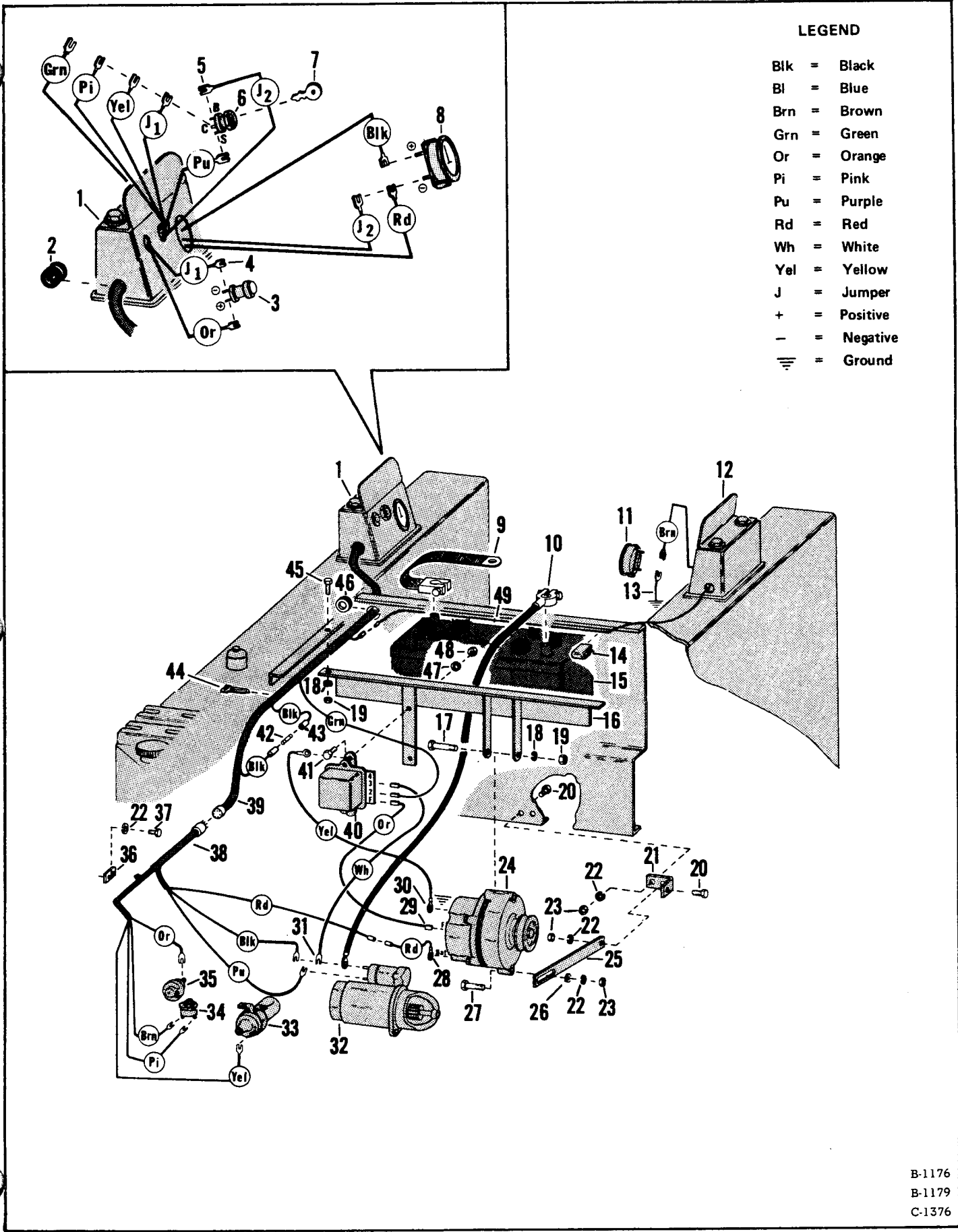

LEGEND

- Blk = Black
- Bl = Blue
- Brn = Brown
- Grn = Green
- Or = Orange
- Pi = Pink
- Pu = Purple
- Rd = Red
- Wh = White
- Yel = Yellow
- J = Jumper
- + = Positive
- = Negative
- ⏏ = Ground

Fig. 211 Electrical Circuitry (Delco Alternator)

B-1176
B-1179
C-1376

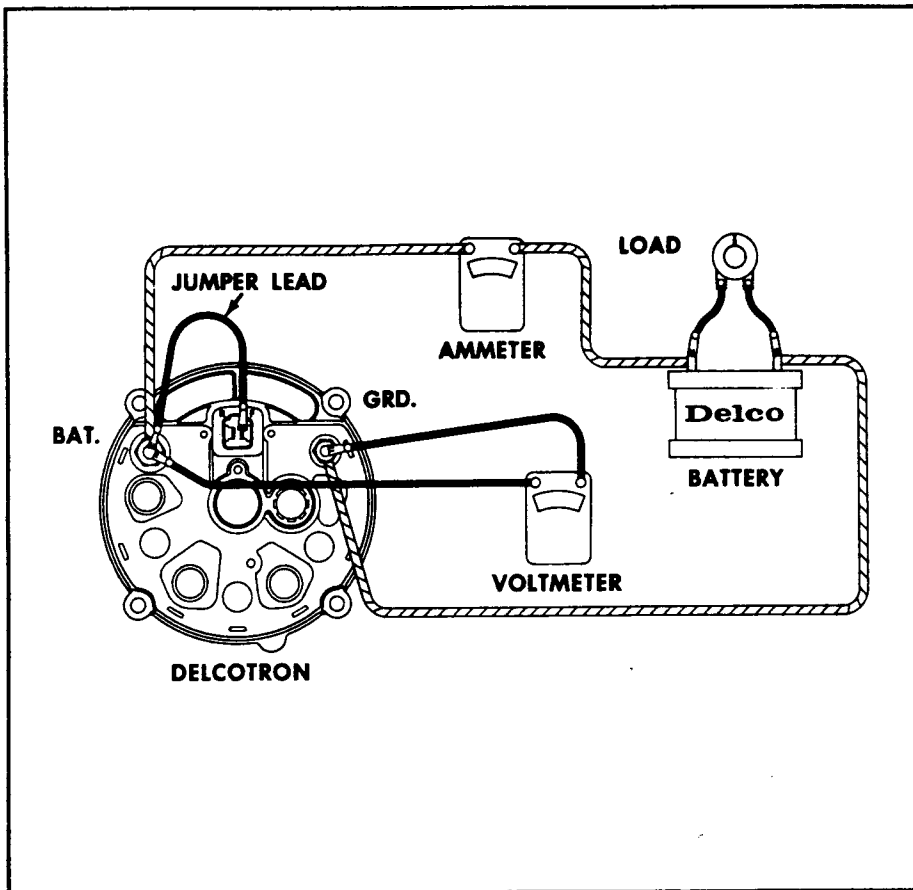

Fig. 212 Alternator Check

ALTERNATOR CHECK

The following test can be made with the alternator in the machine. Disconnect all wires from the alternator except the ground wire. Connect a jumper lead from the field terminal to the output terminal. Also connect a voltmeter and ammeter into the circuit as shown in the wiring diagram (Figure 212).

With the engine at full RPM and a carbon pile rheostat (equivalent to 25 amp. current draw) connected across the battery, the alternator must provide an output of at least 14 amps (maximum rated output is 22 amps). If the alternator does not provide at least 14 amps, it is defective and should be serviced at an authorized Delco-Remy Service Center.

If the alternator charging rate falls within allowable limits, but the battery is still undercharged or overcharged, the following voltage regulator tests should be made using a voltmeter or 12 volt test light.

NOTE: An overcharged battery condition is usually indicated by the battery using an excessive amount of water, or by being hot on top.

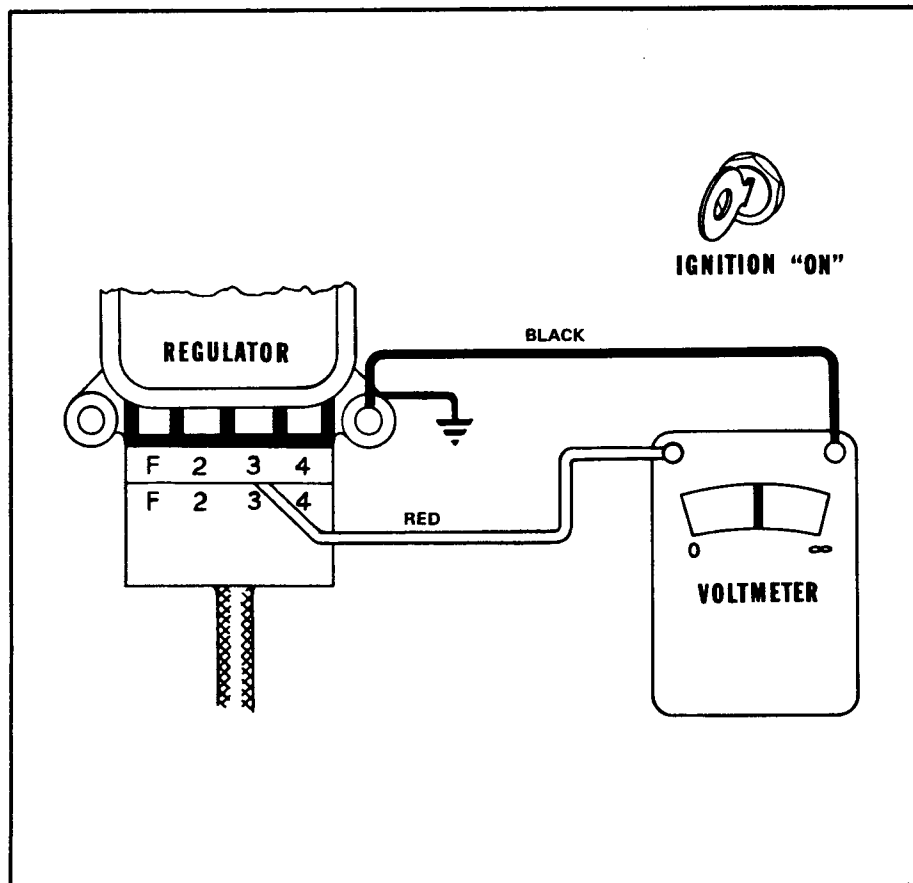

Fig. 213 Regulator Check #1

REGULATOR CHECK #1

The following test can be made with the regulator in the machine. Connect the voltmeter red lead (positive) to #3 terminal on the regulator. Connect the voltmeter black lead (ground) to the base of the regulator (Figure 213). The ignition switch should be turned on. If the reading is very low or zero, the circuit is open between the battery and #3 terminal on the regulator.

A 12 volt test light can also be used. Connect one lead of the test light to #3 terminal on the regulator and connect the other lead to the regulator base. The ignition switch should be turned on. The test light should light. If it doesn't, an open circuit is indicated between the battery and #3 terminal.

REGULATOR CHECK #2

The following test can be made with the regulator in the machine. Connect the voltmeter red lead (positive) to the #2 terminal on the regulator. Connect the voltmeter black lead (ground) to the base of the regulator (Figure 214). The ignition switch must be turned on. Near battery voltage should be indicated on the voltmeter. If a

very low or zero reading is indicated, the circuit is open between #2 terminal on the regulator and the ignition switch and the wiring should be replaced.

A 12 volt test light can also be used. Connect one lead of the test light to #2 terminal on the regulator and connect the other lead to the regulator base (ground). With the ignition switch on, the test light should light. If it doesn't, the circuit is open between #2 terminal and the ignition switch. A loud click should be heard whenever the #2 wire leading to the regulator is disconnected or reconnected.

REGULATOR CHECK #3

This test can be made with the regulator in the machine. Disconnect the wire leading to the F (field) terminal on the regulator. Connect the red lead (positive) to the F (field) terminal on the regulator. Connect the black lead (ground) to the regulator base (Figure 215). The ignition switch must be turned on. A zero reading would indicate the contact closing voltage setting is incorrect and the regulator unit should be adjusted or replaced.

A 12 volt test light can also be used. Connect one lead to the F terminal on the regulator. Connect the other lead to the regulator base (ground). The ignition switch must be on. The test light should light. If the light fails to light, readjust the voltage setting or replace the regulator.

If the battery is undercharged and has low voltage, the upper contacts in the voltage regulator are closing too soon.

If the battery is overcharged and losing water due to too high a charging rate, the upper contacts in the voltage regulator are not closing soon enough.

If either condition exists, have the regulator adjusted to specifications at an authorized Delco-Remy Service Center.

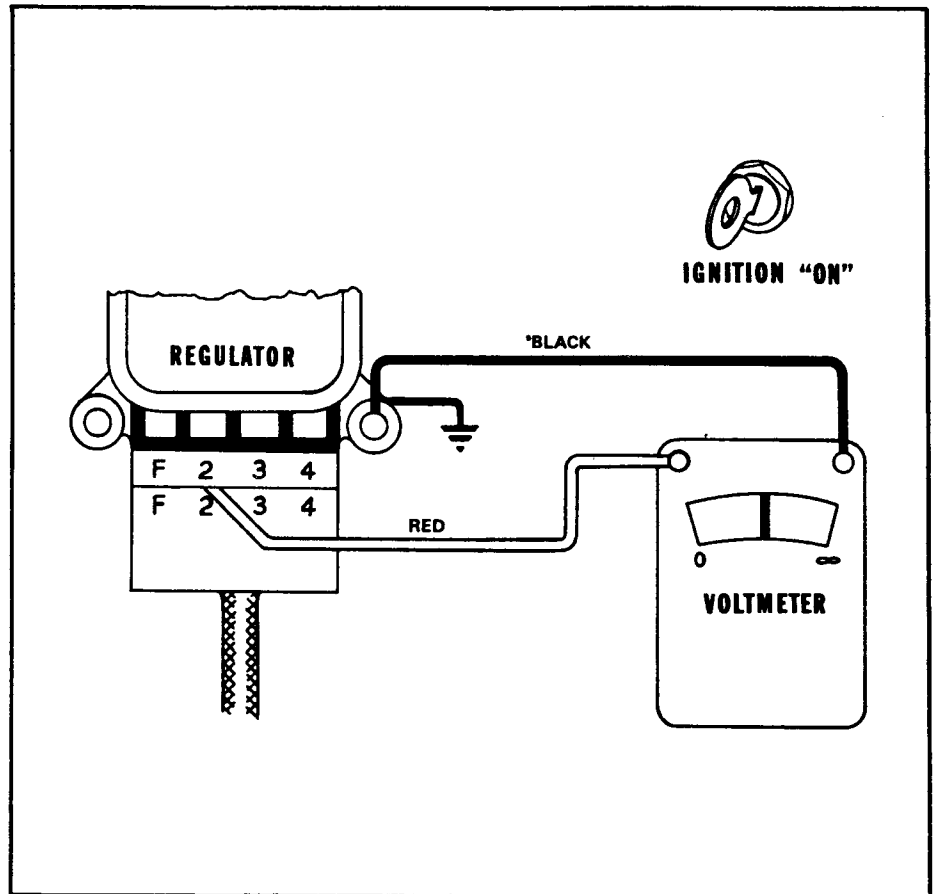

Fig. 214 Regulator Check #2

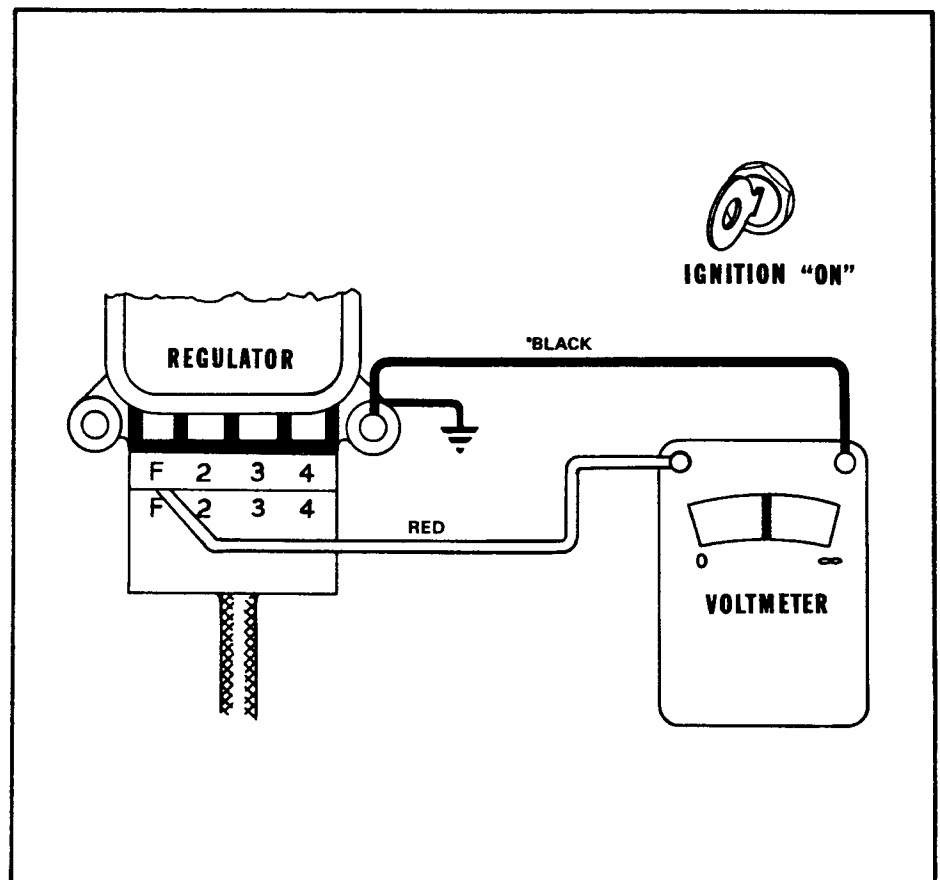

Fig. 215 Regulator Check #3

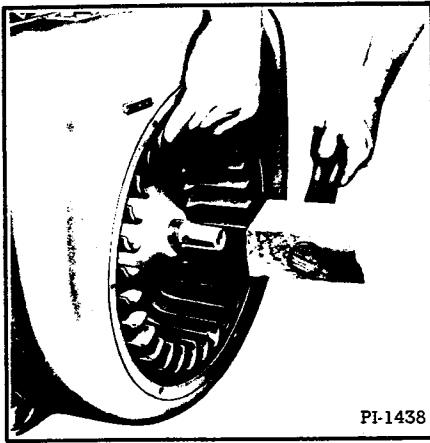

Fig. 216 Removing Flywheel

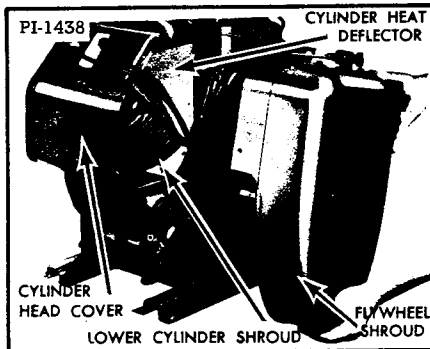

Fig. 217 Removing Shrouding

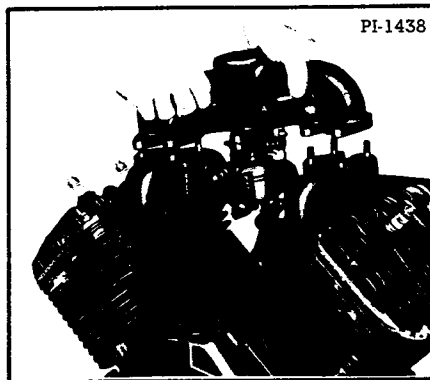

Fig. 218 Removing Manifolds

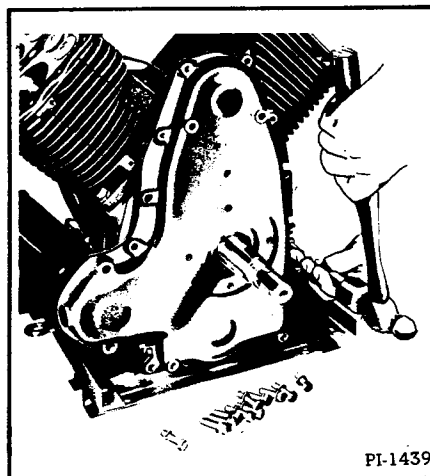

Fig. 219 Removing Gear Cover

When ordering engine parts, include the engine specification number.

ENGINE RECONDITIONING

Engine repairs should be made only by a mechanic who has had experience in such work. When disassembling the engine it is advisable to have several boxes available so that parts belonging to certain groups can be kept together. Capscrews of various lengths are used in the engine, therefore great care must be exercised in reassembly, so the right screw will be used in the various places. Otherwise, damage may result.

Tighten the cap screws and nuts of the manifolds, cylinder heads, gear cover, oil pan, connecting rods, cylinder blocks, main bearing plate and the spark plugs to the specified torque readings indicated in the following paragraphs of reassembly.

While the engine is partly or fully dismantled, all the parts should be thoroughly cleaned. Remove all accumulated dirt between the fins.

Follow this order in disassembling the engine: To reassemble, reverse the order.

ACCESSORIES

Remove the engine oil filter, starter, hydraulic pump, variable speed sheave and any other attaching parts first.

FLYWHEEL

Remove the flywheel screen. Remove the flywheel nut and washer. The flywheel is mounted to a taper on the crankshaft. Take a firm hold of the fins and pull outward. At the same time, strike the end of the crankshaft with a soft hammer (Figure 216). The flywheel will slide off the taper of the crankshaft and bearings. When reassembling the flywheel, be sure the Woodruff key is in position on the shaft and the keyway in the flywheel is lined up accurately with the key.

AIR SHROUDING

To disassemble air shrouding, first remove the cylinder head covers (Figure 217) and the screws mounting the flywheel shroud to the lower cylinder shrouds and cylinder heat deflectors. Then remove the screws holding the flywheel shroud to the gear cover.

CARBURETOR & MANIFOLDS

The carburetor and manifolds can be removed in sections (Figure 218).

In reassembly, tighten the nuts for mounting the manifolds to 14 to 18 ft. lbs. torque. Tightening beyond specification may cause the flanges to break.

CYLINDER HEAD

The cylinder head must be removed if it is necessary to regrind valves, or to do work on the piston, rings or connecting rods. All of the cylinder head screws are plainly in view and can be easily removed. Screws of different lengths are used but these can be properly reassembled according to the various lengths of cylinder head bosses.

Before reassembling the cylinder heads, remove all carbon and lead deposits. Use new cylinder head gaskets in reassembly, as the old gaskets will be so compressed and hard, they may not seal properly.

Use a mixture of graphite and oil on the cylinder head screws to prevent them from rusting tight against the cylinder block. Tighten cylinder head screws to 22 - 24 ft. lbs. torque. After the initial run-in, retorque the head screws.

GEAR COVER

Disconnect the governor linkage before removing the gear cover, since the same mounting screws are used for the governor housing and gear cover. Remove the gear cover screws and drive out the two dowel pins (Figure 219). You can then remove the cover, exposing the timing gears (Figure 220). In reassembly, tighten the cap screws to 14 - 18 ft. lbs. torque.

CAMSHAFT GEAR

Remove the three cap screws and lock washers which hold the gear to the end of the camshaft (Figure 220). Note that the camshaft gear has offset holes to provide accurate assembly for valve timing.

IDLER GEAR & SHAFT

Remove the socket head (Allen-head) set screw that locks the idler shaft in place (Figure 221). The screw is located in the side of the crankcase behind the distributor mounting flange. Remove the idler gear and shaft using a gear puller.

In reassembly, be sure the oil groove in the shaft is facing up. Drive the shaft into the crankshaft with a soft metal hammer. Maintain a .003 to .004 inch clearance between the idler gear and the shoulder of the shaft.

OIL PAN

The engine can now be inverted so the supports and oil pan can be removed (Figure 222). In reassembly, tighten the oil pan mounting screws to 6-9 ft. lbs. torque.

OIL PUMP

Remove the locknut and pump driver gear from the shaft. If the gear is too tight to remove by hand, use a puller. Hammering on the end of the shaft to loosen the gear will damage the pump.

Remove the slotted pipe plug from the bottom of the crankcase (Figure 223). Using a 5/32" Allen wrench, remove the lock screw from the pipe plug hole. Withdraw the oil pump from inside the crankcase. If the pump fits too tight to remove by hand, tap the front of the pump housing (not the shaft) with a hammer and brass rod.

In reassembly, be sure the lockscrew seat in the pump housing lines up with the lockscrew hole in the crankcase.

PISTONS & CONNECTING RODS

Using a 1/2" socket wrench, loosen and remove the hex locknuts from the connecting rod bolts. By tapping the ends of the bolts lightly, the connecting rod cap will release from the bolts.

Scrape off all carbon deposits that might interfere with removal of the position from the upper end of the cylinder. Turn the crankshaft until the piston is at the top of its stroke. Push the connecting rod and piston assembly upward and out through the top of the cylinder. Be careful not to scrape the crank pin by allowing the rod bolts to strike or scrape across it. Place the cap on the connecting rod immediately to prevent mismatching in reassembly. Be sure any shims are in place before putting the cap on.

NOTE: These models of engines were originally furnished with babbitt cast connecting rod bearings. Shell bearing rods are being used for current production engines. The shell bearing rods are interchangeable with babbitt bearing rods for service replacement.

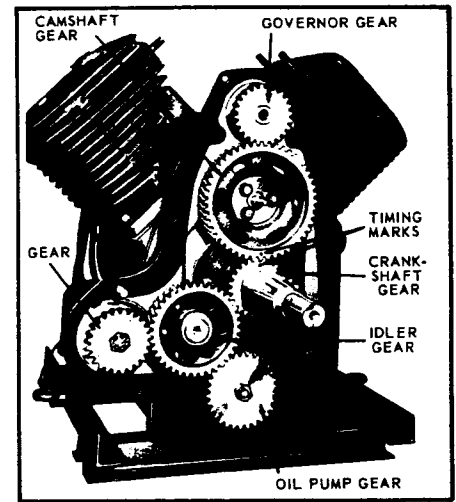

Fig. 220 Removing Camshaft Gear

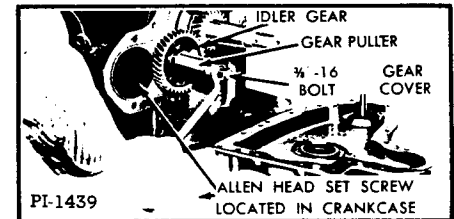

Fig. 221 Removing Idler Gear

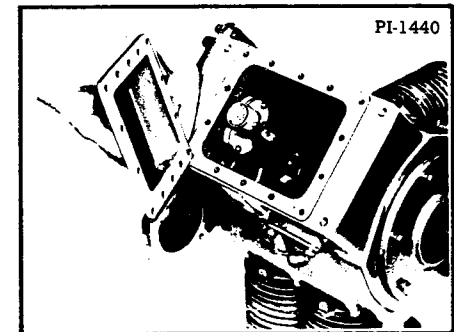

Fig. 222 Removing the Oil Pan

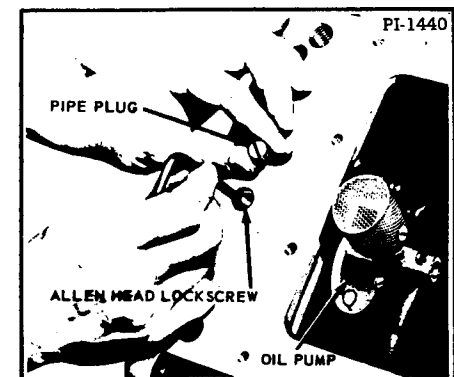
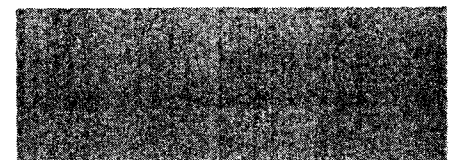

Fig. 223 Removing Oil Pump Lockscrew



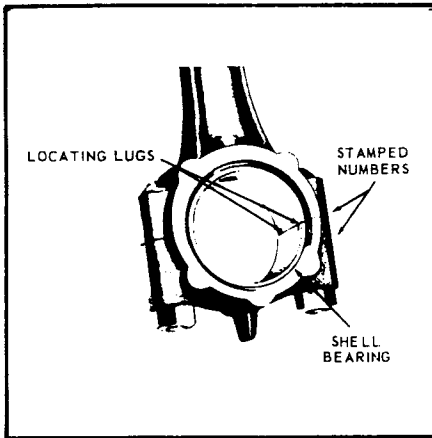

Fig. 224 Bearing Locating Lugs

Be careful, in reassembly, to mount the bearings properly. The cap should be assembled to the rod so the locating lugs of the bearing halves are both toward the same side (Figure 224). Refer to the chart (Figure 229) for clearance between the bearing and crank pin.

When reassembling the piston to the engine, the wide section of the piston skirt must be toward the maximum thrust side (opposite the crankshaft rotation, (Figure 225). The clearance between the piston skirt and cylinder must be measured in the center of the thrust face at the bottom of the piston skirt. Refer to Figure 229 for proper skirt clearance.

In reassembly, be sure the piston and connecting rod assemblies are put back into the same bore from which they are removed. Use a suitable ring compressor and stagger the piston ring gaps 90° apart around the piston. Oil the pistons, rings, wrist pins, rod bearings and cylinder walls before assembly.

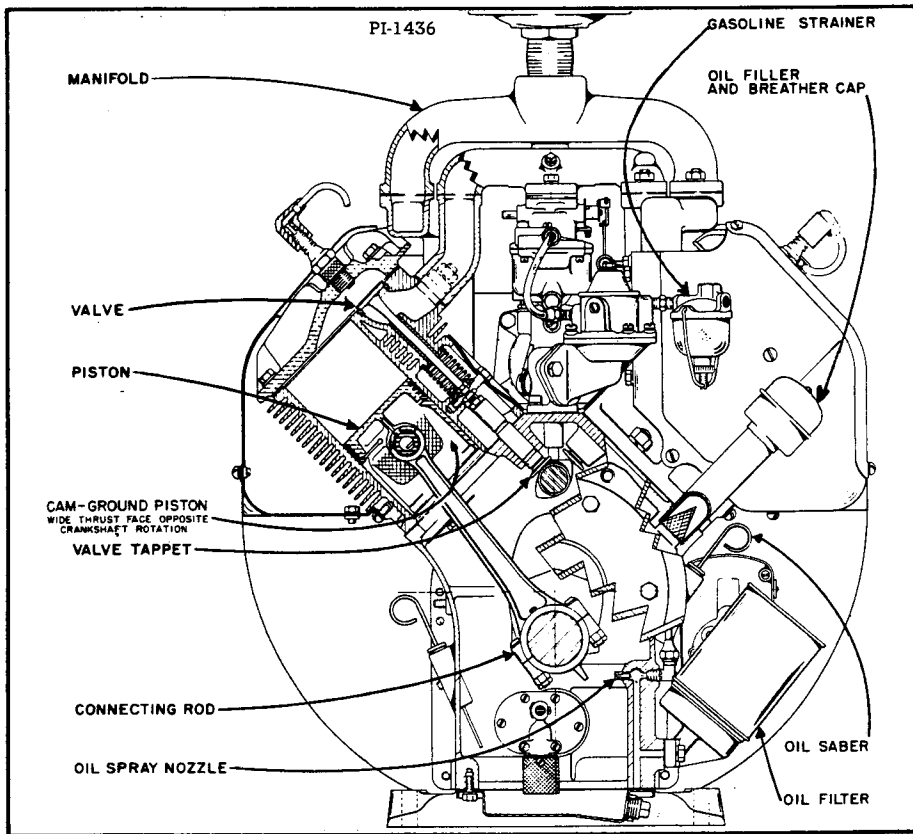

Fig. 225 Engine Cutaway

WARNING

Identical numbers are stamped on the side of the rod and its corresponding cap. These numbers must be on the same side of the connecting rod when installed in the engine. Be sure the hole in the connecting rod cap is facing toward the oil spray nozzle (Figure 226). Install new nuts on the connecting rod bolts and torque to 22 - 28 ft. lbs.

PISTON RINGS

If a ring expander tool is not available, install rings by placing the open end of the ring on the piston first (Figure 227). Spread the ring only far enough to slip over the piston and into the correct groove, being careful not to distort the ring. Install the bottom ring first. Work toward the head of the piston, installing the top ring last.

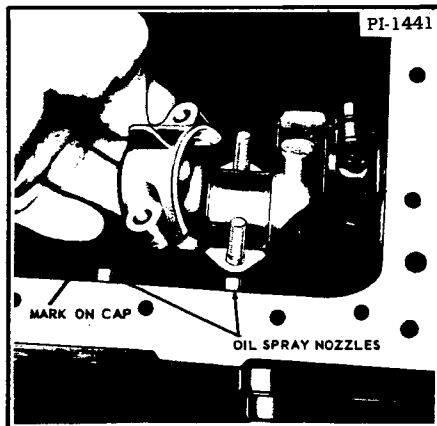

Fig. 226 Installing Rod Caps

Each piston has two compression rings, a scraper ring and an oil ring (Figure 228). The outer diameter of the top compression ring is chrome plated. Mount the scraper ring with the scraper edge down, otherwise oil pumping and excessive oil consumption will result.

CYLINDER BLOCKS

Clean all dirt and foreign deposits from between the cylinder fins and manifold ports.

The cylinder blocks do not need to be removed unless the cylinder bore is scored, out-of-round, or worn oversize more than .005 inch. In this event, the blocks will need to be removed, rebored and fitted with oversize pistons and rings. In reassembly, tighten the four cylinder block mounting nuts to 40 - 50 ft. lbs. torque.

VALVES & SEAT INSERTS

Remove the valve tappet inspection plate and compress the valve springs with a standard automotive type valve lifter (Figure 230). Insert a rag into the opening at the bottom of the valve chamber so the retaining locks do not fall into the engine crankcase. Remove the retaining locks, seats, springs and valves and clean these, as well as the ports and guides, of all carbon and gum deposits. Tag each valve so that in reassembly they will be mounted in the same guide they were removed from. Replace valves that are burned or pitted.

The exhaust valve face and replaceable exhaust seat inserts are of stellite material. A positive type valve rotator is furnished as standard equipment on the exhaust valves. Clean and inspect operation of the rotor.

The inlet and exhaust valve inserts can be removed, when replacement becomes necessary by using an insert puller.

Before grinding valves, inspect the valve guides for possible replacement. The valve face is ground at a 45° angle to the vertical centerline of the valve stem. The valve seat insert should also be ground at a 45° angle. After grinding, lap valves in place until a uniform ring will show entirely around the face of the valve. Clean the valves. Wash the block thoroughly with a hot solution of soap and water. Wipe the cylinder walls with clean, lint free rags and light engine oil, especially if the cylinders were rebored and honed.

Valve guides in the cylinder block are replaceable. The valve stem has a clearance of .003 to .005 inch in the guide. When the clearance becomes .007 inch, the guide should be driven out and a new pressed into place.

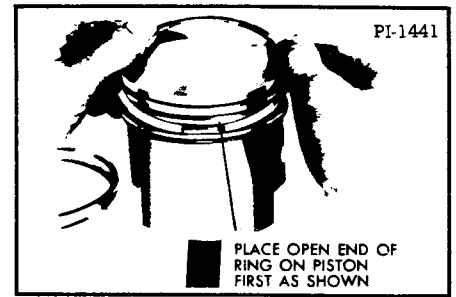

Fig. 227 Installing Rings

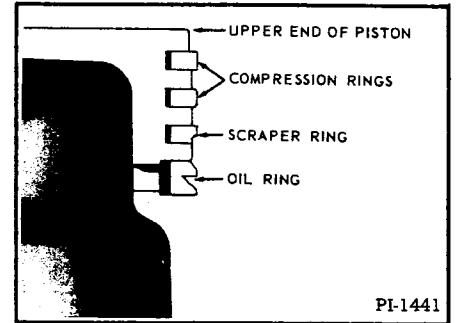

Fig. 228 Installing Rings

Piston to Cylinder at Piston Skirt (thrust face)		.0035 - .004
Piston Ring Gap		.010 - .020
Piston Ring Side Clearance in Groove	Top Ring	.002 - .0035
	2nd & 3rd Rings	.001 - .0025
	Oil Ring	.0025 - .004
Piston Pin to Connecting Rod Bushing		.0005 - .0011
Piston Pin to Piston		.0000 - .0008 tight
Connecting Rod to Crank Pin-Side Clearance		.009 - .018
Connecting Rod Shell Bearing to Crank Pin Diameter (Vertical)		.0012 - .0034
Connecting Rod Babbitt Bearing to Crank Pin		.0007 - .0020

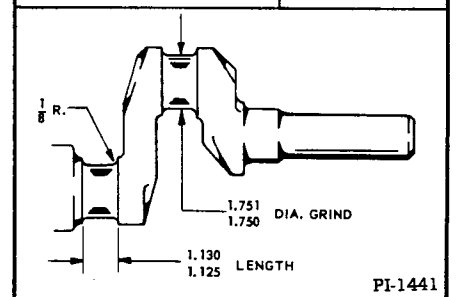

Fig. 229 Crankshaft

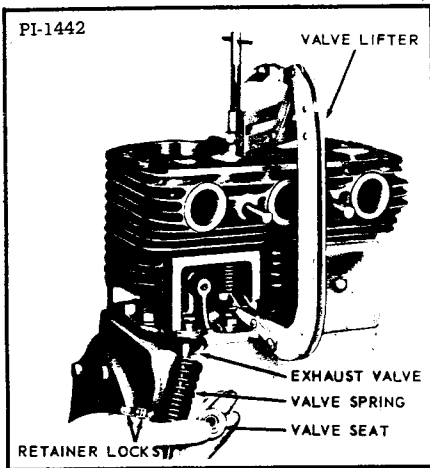

Fig. 230 Removing Valves

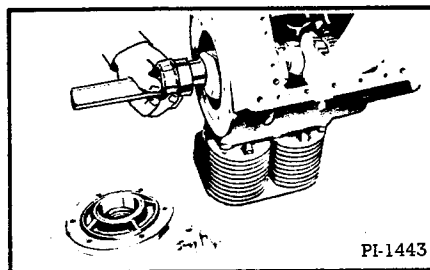

Fig. 231 Removing the Crankshaft

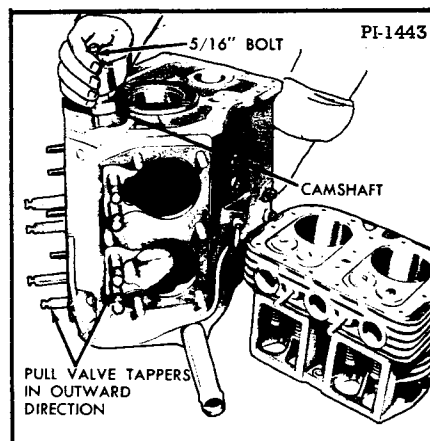

Fig. 232 Withdrawing the Camshaft

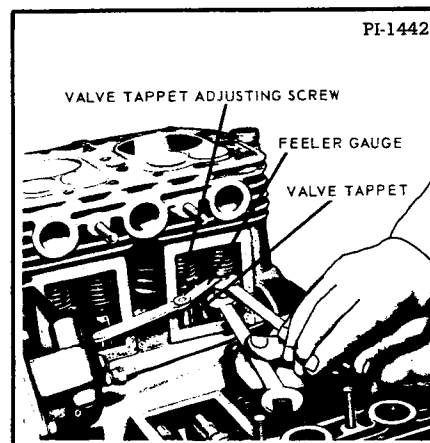

Fig. 233 Adjusting Valve Tappets

CRANKSHAFT

To remove the crankshaft (Figure 231), take out the six capscrews in the main bearing plate at the take-off end. Pry the plate off and remove the crankshaft from the end of the crankcase. In reassembly, use the same quantity and thickness bearing plate gaskets and shims as were removed. They are necessary to provide proper end play for the tapered roller crankshaft bearings.

NOTE: End play should be .002 to .004 inch when the engine is cold.

There is practically no wear in these bearings, so readjustment is seldom necessary after proper assembly.

WARNING

In reassembly, the timing marks on the crankshaft gear and camshaft gear must be aligned (Figure 220), or the engine will not operate properly. If timing is off considerably, the engine will not run at all.

The mounting holes in the main bearing plate are offset so the plate will be correctly mounted for main bearing lubrication. Tighten the main bearing cap screws to 25 - 30 ft. lbs. torque.

CAMSHAFT

The camshaft must be withdrawn from the flywheel end of the engine (Figure 232). When replacing, be sure the spring and plunger are in place in the end of the camshaft, as they hold the camshaft in position endwise.

VALVE TAPPETS

Take the valve tappets out after the camshaft is removed. In reassembly, the tappets must be inserted in their proper position in the crankcase before the camshaft is installed.

After the cylinder blocks have been assembled to the crankcase, adjust the valve tappets (Figure 233). With the tappets in their lowest positions (engine cold) the clearance should be .008 inch for the inlet and .016 inch for the exhaust, with or without stellite valves.

TECHNICAL DATA (Wisconsin)

FITS & CLEARANCES

Breaker Point Gap018 - .022
Spark Plug Gap030
Idler Gear to Shaft Collar Clearance003 - .004
Piston to Cylinder at Piston Skirt (Thrust Face)0035 - .004
Piston Ring Gap010 - .020
Piston Ring Side Clearance in Grooves	
Top Ring002 - .0035
2nd Ring001 - .0025
3rd Ring001 - .0025
Oil Ring0025 - .004
Piston Pin to Connecting Rod Bushing0005 - .0011
Piston Pin to Piston0000 - .0008
Connecting Rod to Crank Pin - Side Clearance009 - .018
Connecting Rod Shell Bearing to Crank Pin Diameter0012 - .0034
Connecting Rod Babbitt Bearing to Crank Pin Diameter0007 - .0020
Crank Pin Diameter	1.751 - 1.750
Crank Pin Length	1.130 - 1.125
Valve Stem Clearance in Guide003 - .005
Valve Stem Clearance in Guide (Maximum Permissible)007
Crankshaft End Play (Cold)002 - .004
Valve Tappets	
Inlet008
Exhaust016

TORQUE VALUES

Spark Plugs	25 - 30 ft. lbs.
Cylinder Head Screws	22 - 24 ft. lbs.
Gear Cover Screws	14 - 18 ft. lbs.
Oil Pan Mounting Screws	6 - 9 ft. lbs.
Connecting Rod Nuts	22 - 28 ft. lbs.
Cylinder Block Mounting Nuts	40 - 50 ft. lbs.
Main Bearing Plate Capscrews	25 - 30 ft. lbs.



KOHLER ENGINE SERVICE

COMPRESSION CHECK

A commercial compression testing gauge should be used in the manner indicated by the manufacturer. An engine in top mechanical condition will show compression of 110 to 120 PSI.

When this figure falls below 100 PSI it indicates leaking rings or valves, or deposits in the combustion chamber which limit the charge entering the combustion chamber.

NOTE: The above reading is based on the engine being run at 1000 RPM.

Compression over 130 PSI indicates a need for removing carbon deposits from the combustion chambers.

CRANKCASE BREATHER

The crankcase breather valve is used to maintain a slight vacuum in the crankcase. All parts must be clean and in good condition. A faulty breather valve may cause high engine temperatures and oil leaks at all engine seals.

An engine in good condition will have crankcase vacuum of 10 to 20 inches water column as read on a V-tube water manometer. If a vacuum is not within the specified range, this could be caused by one of the following:

1. Clogged crankcase Breather--Can cause positive pressures to build up in the crankcase. Disassemble and clean the breather assembly. Re-check the pressure after reinstalling the breather valve.
2. Worn Oil Seals--Can cause lack of vacuum. Oil leakage is usually evident around worn oil seals.
3. Blowby--Leaky Valves--Can cause positive pressures. Make a compression test on the engine.

GOVERNOR & SPEED CONTROL

Operating speed is determined by the throttle control setting. The governor maintains engine speed over varying loads and serves as a top speed limiting device. A stop (Figure 235, Item A) is provided to prevent the engines exceeding the recommended top speed.

Governor sensitivity may be adjusted by means of a screw (Item B). If too sensitive, speed surging on change of load (hunting) may occur. A sudden drop in speed when a load is applied indicates that the governor should be set for greater sensitivity. To increase sensitivity, increase spring tension by turning the hex nuts farther onto the eye screw (Item B). Relieve spring tension to decrease sensitivity.

TEMPERATURE	VISCOSITY
Below 0° F	SAE 5W-20
0° F to 30° F	SAE 10W-30
Above 30° F	SAE 30

Fig. 234 Oil Specifications

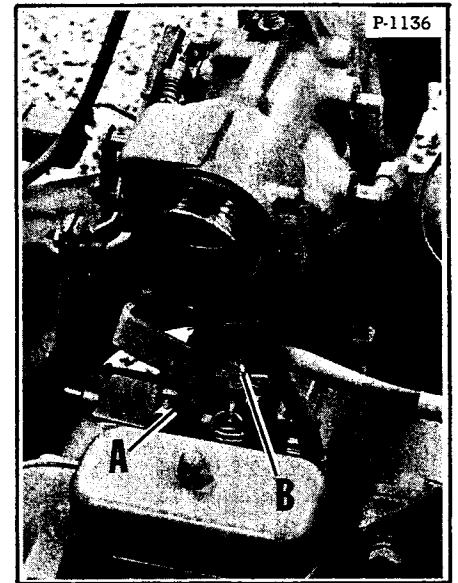

Fig. 235 Governor Adjustment

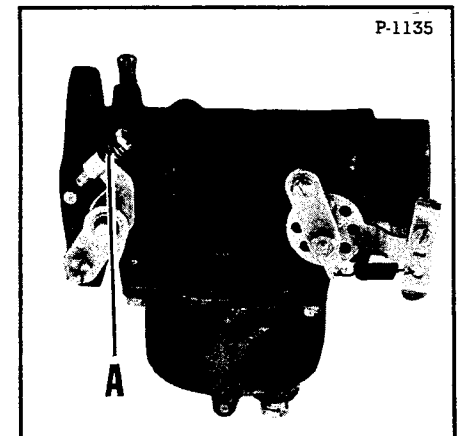
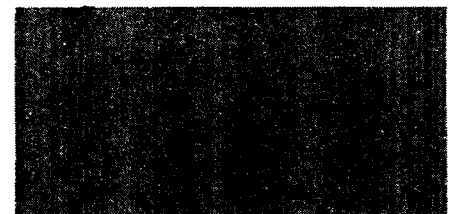

Fig. 236 Carburetor Adjustment



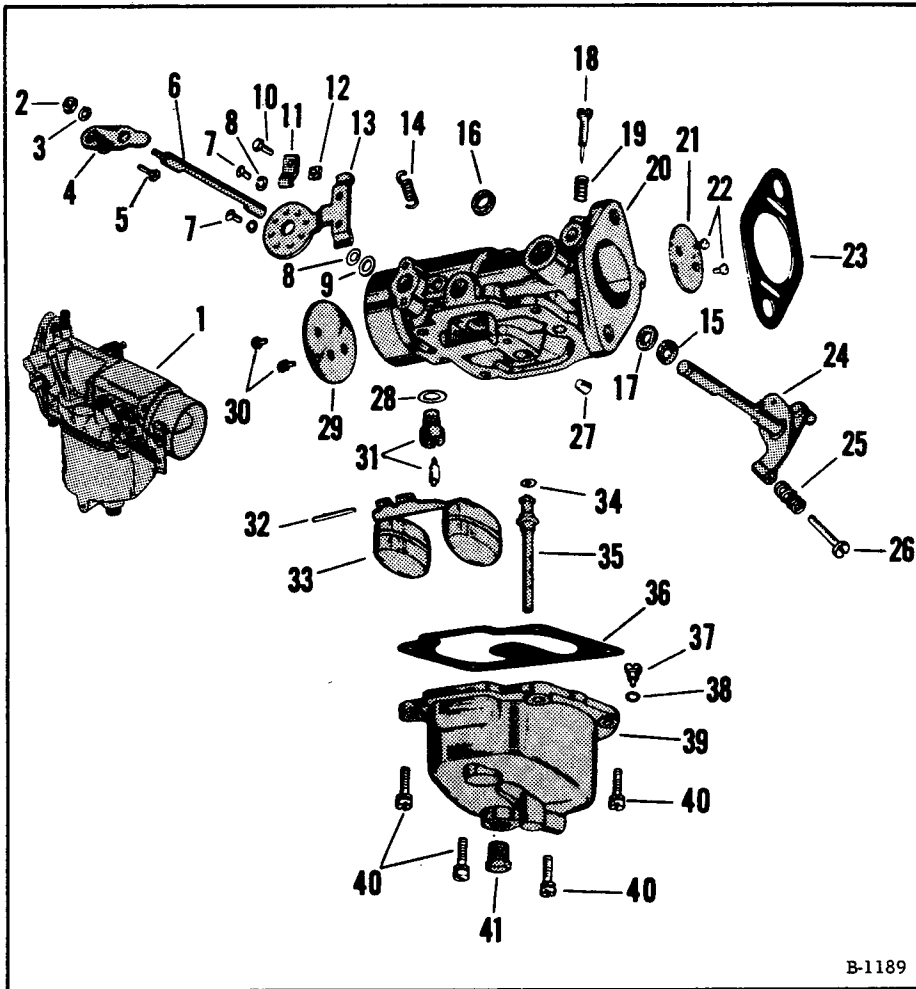

Fig. 237 Gasoline Carburetor Breakdown

NOTE: When sensitivity is changed, the speed stop screw (Item A) setting must also be changed.

When sensitivity is increased, the stop screw should be turned out to maintain 3200 RPM maximum. Turn the screw in when sensitivity is decreased.

CARBURETOR ADJUSTMENT

1. This carburetor is a fixed jet type and no adjustment can be made of the high speed mixture (jets are available for high altitude operation).
2. The idle speed screw (Figure 236, Item A) adjustment should be made to an engine speed no less than 1000 RPM.
3. If the idle speed screw is completely out of adjustment and the engine will not start, turn it in lightly against the seat. Back it out 1-1/4 turns. Follow step 2 for final adjustment after starting the engine.
4. Be sure the choke cable is adjusted to full choke position.

CARBURETOR RECONDITIONING (Gasoline) (Figure 237).

To remove the fuel bowl:

1. With the carburetor inverted, loosen the fuel bowl plug (Item 41).
2. Remove the four fuel bowl assembly screws (Item 40). Separate the fuel bowl (Item 39) from the throttle body assembly.
3. Remove the bowl to body flange gasket (Item 36).

To disassemble the throttle body:

1. With the throttle body inverted, remove the float axle (Item 32) by pressing against the end of the axle with the blade of a small screwdriver. Remove the float assembly.
2. Remove the discharge tube and well assembly (Item 35). Remove the rubber seal (Item 34) from the end of the tube.
3. Remove the fuel valve (needle and seat) (Item 31) with its gasket (Item 28).
4. Remove the idle adjusting needle (Item 18) and spring (Item 19).
5. Mark the throttle lever and throttle body with a file or prick punch as a guide to correct assembly. Remove the throttle plate screws (Item 22), throttle plate (Item 21)

and throttle lever and shaft assembly (Item 24).

NOTE: If screws are riveted, they must be filed away before the screws can be removed. Do not attempt to re-rivet upon assembly.

6. Remove a throttle shaft seal (Item 17) and retainer (Item 15) from each side of the throttle body, using a small screwdriver to lift the parts out of the shaft holes.
7. Mark the choke lever, choke bracket and adjacent shaft boss with a file or prick punch as a guide to correct reassembly. Remove the choke lever return spring (Item 14).
8. Remove the choke plate screws (Item 30) and choke plate (Item 29). Remove the choke shaft nut (Item 2), lockwasher (Item 3) and lever (Item 4).
9. Remove the choke bracket screws (Item 7), lockwashers and bracket (Item 13).
10. Remove the choke shaft (Item 6), choke shaft seal (Item 9) and retainer (Item 8) from the choke shaft boss. Use a small screwdriver to lift out the retainer and seal.
11. Insert a 6" length of 1/8" diameter rod into the shaft hole and drive out the choke shaft plug (Item 27).

To disassemble the fuel bowl:

1. Remove the main jet (Item 37) and fiber washer (Item 38).
2. Remove the fuel bowl drain plug (Item 41).

Thoroughly clean all metal parts, using a special carburetor parts cleaner. Rinse in solvent. Blow out all passages and channels in the castings with compressed air. Reverse the air flow through each passage to insure the removal of all dirt particles.

WARNING

Never use a wire or drill to clean out the jets.

Inspect all parts and replace any that are damaged or worn. Always use a repair kit. For the correct repair kit to use, see your Bobcat Parts Book.

To reassemble the fuel bowl assembly:

1. Install the main jet (Item 37) with its fiber washer. Install the fuel bowl drain plug (Item 41) but do not tighten at this time.

To assemble the throttle body assembly:

1. Install a new choke shaft seal (Item 9) (lip side out) and retainer (Item 8).
2. Attach the choke bracket (Item 13) with lockwashers and screws. Make sure the bracket is aligned to the match marks made at the time of disassembly.
3. Insert the blank end of the choke shaft (Item 6) into the choke shaft hole and rotate the shaft so the flat side is out. Attach the choke plate loosely with its screws. Close the choke. Align the choke plate for best closing. Tighten the screws.
4. Assemble the choke lever to the choke shaft with a lockwasher (Item 3) and nut (Item 2). Align the lever to the match marks made during disassembly. Tighten the nut.

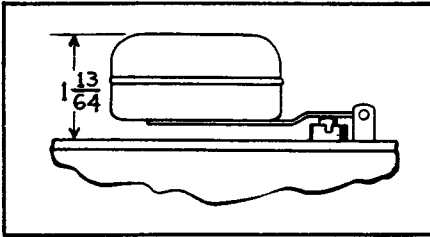

Fig. 238 Float Adjustment

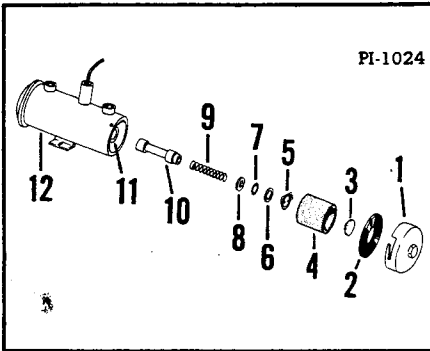
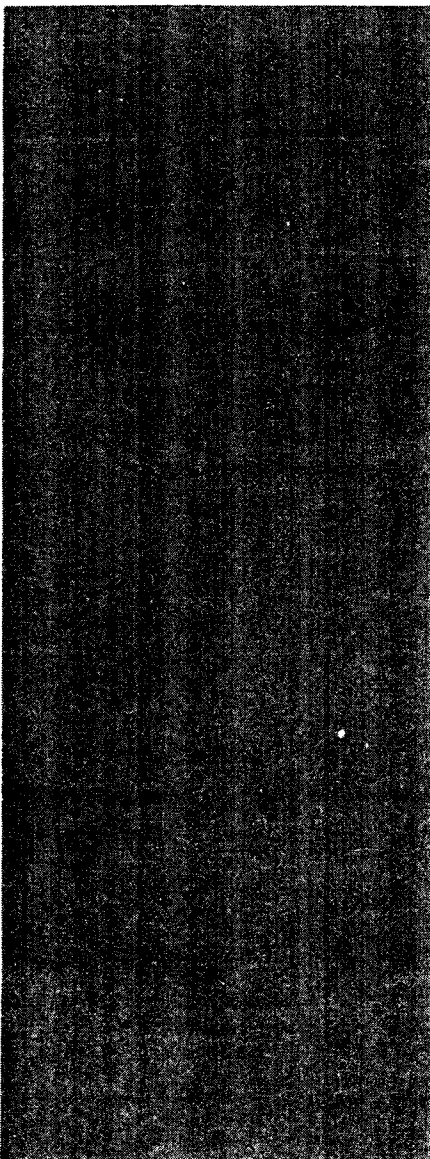

Fig. 239 Electric Fuel Pump



5. Install a new throttle shaft seal (Item 17) into the retainer (Item 15) with the lip of the seal in the open side of the retainer.
6. Press the seal and retainer into the throttle shaft hole until the outer face of the retainer is flush with the shaft boss. Slight tapping with a light hammer may be required. Repeat at both sides of the throttle body.
7. Install the throttle shaft and lever assembly (Item 24) with a slight twisting motion of the shaft to ease the shaft through the seals.
8. Attach the throttle plate (Item 21) to the throttle shaft, leaving the screws loose. Close the throttle and align the plate for best closing. Tighten the screws.
9. With the throttle body inverted, install a new fuel valve seat (Item 31) with a new gasket. Use a wide blade screwdriver or seat wrench.
10. Insert the cone end of the fuel valve needle in the fuel valve seat. Place the float and lever assembly (Item 33) in position on the throttle body. Align the hole in the float lever bushing with the holes in the axle bracket. Install the float axle.
11. With the throttle body inverted and the float lever holding the needle valve on its seat, check the distance from the throttle body flange to the top of each float. This dimension should be 1-13/64" (Figure 238).
12. Install the idle adjusting needle (Item 18) and spring. Turn the needle IN lightly against its seat. Back the needle OUT 1-1/4 turns as a preliminary adjustment.
13. Apply a light coating of lubricating oil to the shoulder end of the discharge tube and well assembly (Item 35) to hold the seal (Item 34) in place. Install the seal end of the assembly into the discharge port of the throttle body.

To assemble the fuel bowl to the throttle body:

1. Place a new body to bowl gasket on the throttle body and position the fuel bowl on the throttle body.
2. Align the holes in the fuel bowl with the holes in the gasket and throttle body. Insert the four assembly screws. Tighten them evenly and securely.
3. Securely tighten the drain plug in the fuel bowl.

ELECTRIC FUEL PUMP SERVICE

To disassemble an electric fuel pump:

1. With a 5/8" wrench, release the bottom cover (Figure 239, Item 1) from the bayonet fittings. Twist the cover by hand to remove it from the pump body.
2. Remove the filter (Item 4) magnet (Item 3) and cover gasket (Item 2). Wash the filter in cleaning solvent and blow out dirt and cleaning solvent with air pressure. Check the cover gasket and replace if deteriorated. Clean the cover.
3. Remove the retainer spring (Item 5) from the plunger (Item 11) using a thin nose plier to spread and remove the ends of the retainer from the tube. Then remove the washer (Item 6), o-ring seal (Item 7), cup valve (Item 8), plunger spring (Item 9) and plunger (Item 10) from the tube (Item 11).
4. Wash the parts in cleaning solvent and blow clear with air pressure. If the plunger does not wash clean or if there are any rough spots, gently clean the surface with crocus cloth. Sloss the pump assembly in cleaning solvent. Blow out the tube with air pressure. To do a complete job, swab the inside of the tube with a cloth wrapped around a stick.

To reassemble an electric fuel pump:

1. Insert the plunger assembly (Item 10) into the tube with the buffer end first. Check the fit by slowly raising and lowering the plunger in the tube. It should move fully without any tendency to stick. If a click cannot be heard, the interrupter assembly is not functioning properly. In this case the pump should be replaced.
2. To complete the assembly, install the plunger spring (Item 9), cup valve (Item 8), o-ring seal (Item 7) and washer (Item 6). Compress the spring (Item 9) and insert the retainer (Item 5) with the ends of the retainer in the side holes of the tube (Item 11).
3. Place the cover gasket and magnet in the bottom cover and assembly the filter and cover assembly. Twist the cover by hand to hold it in position on the pump housing. With a 5/8" wrench, securely tighten the bottom cover.

WARNING

Do not tamper with the seal at the center of the mounting bracket (at the side of the pump) as it retains the dry gas, which surrounds the electrical system, in the upper portion of the pump.

To inspect and adjust:

Electric fuel pump delivery should be 1-3/4 PSI maximum. Use a low pressure gauge or water manometer to check this. Pressure can be increased or decreased by stretching or compressing the spring.

CARBURETOR ADJUSTMENTS (LPG)

1. Turn the high speed needle counterclockwise one and one half turns (from closed position), and start the engine.
2. When the engine reaches normal operating temperature, accelerate and check response. Operate the engine under load and adjust the high speed needle for the leanest mixture which will allow satisfactory acceleration and steady governor operation.

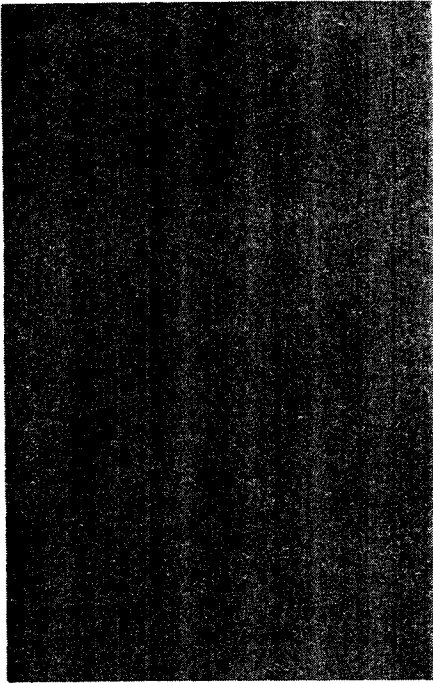

3. If the engine misses and backfires, the high speed mixture is too lean. The high speed adjustment screw must be turned counterclockwise 1/4 turn at a time to correct this condition.
4. If the engine shows sooty exhaust and is sluggish, the mixture is too rich. To correct, the high speed adjustment screw should be turned clockwise until smooth running is reached.
5. To make a final check of the high speed adjustment, operate under full load and make other corrections necessary.
6. Idle speed screw adjustments should be made at a speed not less than 1000 RPM. Adjust the idle mixture screw (approximately 2-1/2 turns open) until smoothest idle is obtained.

WARNING

Do not use force on the high speed needle or idle mixture screw--they will be damaged.

CARBURETOR RECONDITIONING (LP Gas) (Figure 240)

To disassemble the LP carburetor:

1. Turn the throttle stop screw (Item 43) to the left until the throttle plate is fully closed.
2. Remove the throttle plate screws (Item 34) and throttle plate (Item 33).
3. Remove the throttle shaft (Item 44).
4. Remove the throttle shaft seal retainers and seals (Items 35 & 36).
5. Take out the venturi retainer screw and remove the venturi (Item 32).
6. Remove the choke plate screws, choke plate (Item 31) and choke shaft (Item 49).
7. Remove the idle adjusting needle and spring (Items 38 & 39).
8. Remove the four idle diaphragm cover screws (Item 57) cover (Item 56) and idle diaphragm (Item 55). Remove the control channel plug (Item 37), fiber washer and spring (Items 41 & 42).

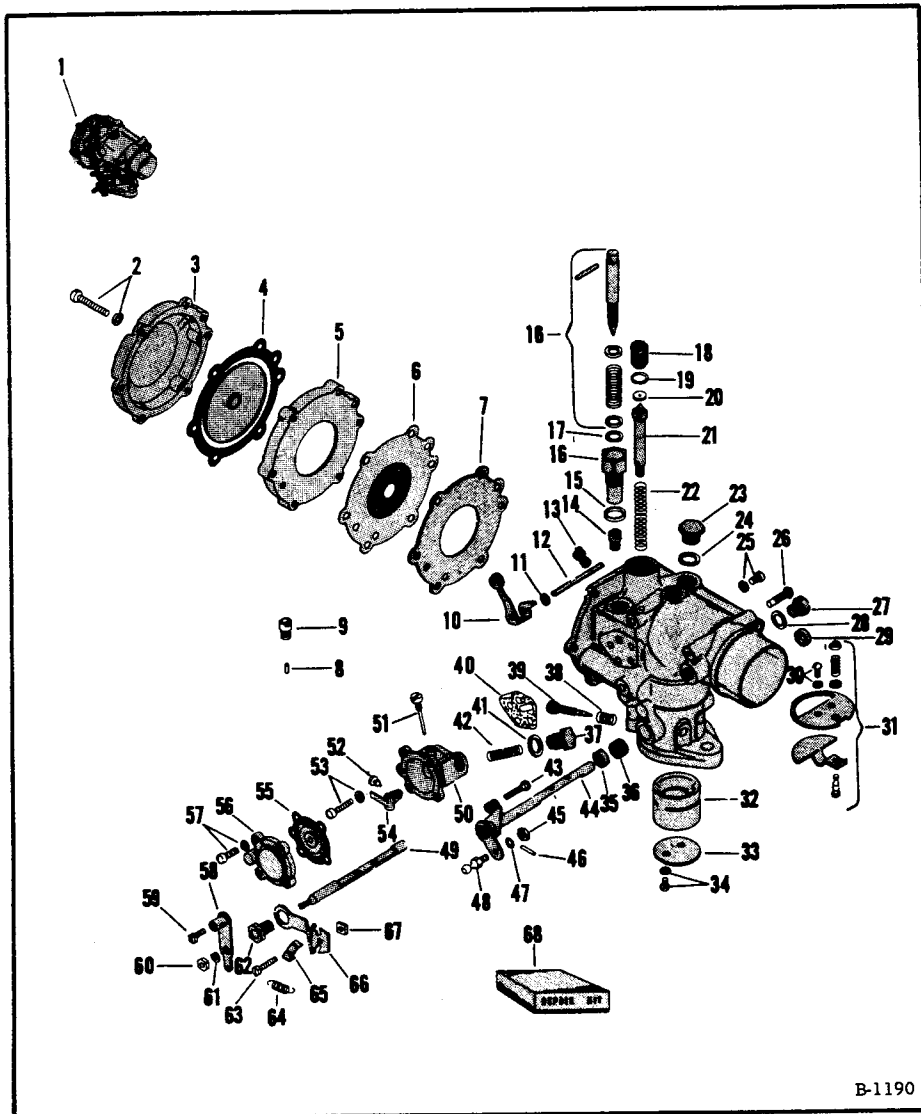

B-1190

Fig. 240 LP Carburetor Breakdown

9. Remove the lever axle (Item 51), diaphragm lever (Item 54) and rubber valve disc (Item 52).
10. Remove the two diaphragm housing screws (Item 53), housing (Item 50) and gasket (Item 40).
11. Remove the diaphragm cover assembly screws (Item 2) and diaphragm assembly (Item 3 thru 7).
12. Separate the diaphragm assembly components.
13. Remove the axle retainer, fuel valve axle (Item 12) and fuel valve lever (Item 10).
14. Remove the inlet orifice (Item 18). The orifice is secured in position with an 8-32 socket head (Allen head) set screw. Loosen this set screw before attempting to remove the inlet orifice.
15. Remove the inlet valve stem (Item 21) and spring.
16. Remove the adjusting needle from the main jet adjustment (Item 16).
17. Use a 5/8" socket wrench to remove the main jet adjustment body (Item 16).
18. Use a special jet wrench to remove the main jet (Item 14).

Thoroughly clean all metal parts, using a special carburetor parts cleaner. Rinse in solvent. Blow out all passages and channels in the casting with compressed air. Reverse the air flow through each passage to insure the removal of all dirt particles.

WARNING

Never use a wire or drill to clean out the jets.

Inspect all parts and replace any that are damaged or worn. Always use a repair kit. For the correct repair kit to use, see your Bobcat Parts Book.

To reassemble the carburetor:

1. Install the main jet (Item 14) and compensator jet (Item 13).
2. Place a new fiber washer on the main jet adjustment body. Install and tighten with a 5/8" socket wrench.
3. Place a new o-ring on the main jet adjusting needle. Seat the adjusting needle, then back it out 2 or 3 turns.
4. Place a new rubber seat on the fuel valve stem (Item 21).
5. Place the fuel valve spring (Item 22) on the fuel valve (Item 21). Insert the valve, spring end first, into the casting.
6. Place a new o-ring on the inlet orifice (Item 18) and turn it part-way into the casting.

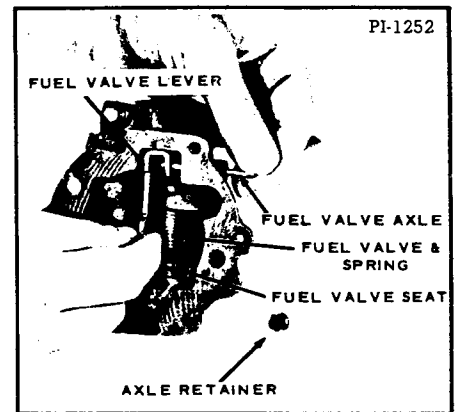

Fig. 241 Installing Fuel Valve Lever

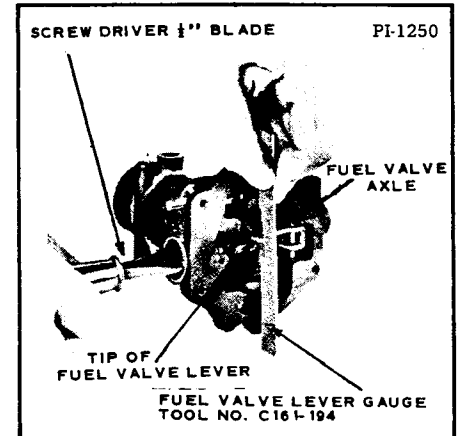

Fig. 242 Adjusting Fuel Valve Lever

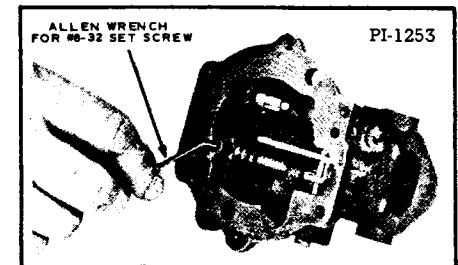
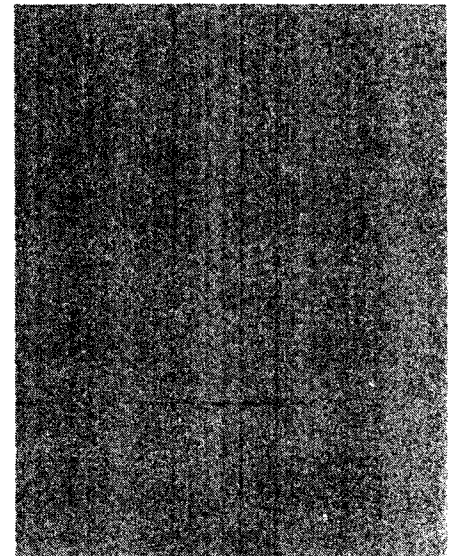
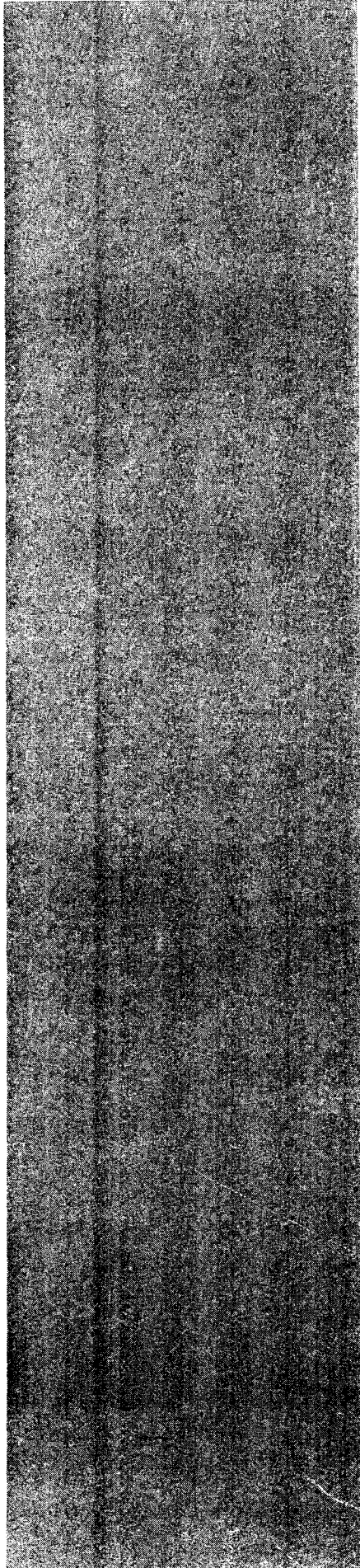

Fig. 243 Securing Fuel Valve Lever





7. Insert the tip of the fuel valve lever into the slot in the valve stem (Figure 241). Install the axle and axle retainer.
8. Place the special fuel valve lever adjusting gauge on the machined surface of the casting and against the nylon roller (Figure 242). Adjust the fuel valve lever to step 2 on the gauge by turning the inlet orifice in or out. Secure it in position by tightening the 8-32 set screw (Figure 243).

NOTE: The fuel valve lever is not adjustable on early type carburetors.

9. Install aligning studs in three of the diaphragm mounting screw holes.
10. Install the diaphragm assembly components in this order:

NOTE: Install the components so the vacuum port and vent channel port openings are in the right positions.

Gasket (Figure 240, Item 7).

Inner Diaphragm (Item 6).

Diaphragm Spacer (Item 5).

Outer Diaphragm (Item 4).

Diaphragm Cover (Item 3).

11. Install three diaphragm assembly screws (Item 2). Remove the aligning studs and install the remaining screws.
12. Install the venturi and secure it with the venturi screw.
13. Place the idle diaphragm gasket on the housing and fasten the housing to the carburetor body with two 3/4" long screws.
14. Insert a new valve disc in the lever assembly from the lever arm side. Position the lever in the housing and secure it with the lever axle.
15. Align the diaphragm and cover on the housing with the cup side of the diaphragm next to the lever. Install the attaching screws and lockwashers.
16. Insert the spring into the idle channel plug. Place the fiber gasket on the plug. Install the plug into the housing.
17. Install the throttle shaft seals and seal retainers. Secure the retainers by staking.
18. Install the throttle plate.
19. Install the idle adjusting screw and spring. Turn the screw in lightly against its seat, then adjust the needle to 1-1/2 to 2 turns open.
20. Place the choke return spring on the choke shaft. Install the choke shaft and choke plate with the relief spring outward.
21. Turn the throttle stop screw to its right to open the throttle for a fast idle.

VAPORIZER-PRIMARY REGULATOR SERVICE

To service the vaporizer - Primary regulator, see page 81.

IGNITION TIMING

The engine is equipped with a timing sight hole which is located on top of the blower housing. Timing marks are stamped on the rim of the blower housing.

To correctly time the magnets to the engine:

1. Remove the No. 1 spark plug. The No. 1 cylinder is on the left side when facing the timing sight hole.
2. Turn the engine over by hand until compression is on the No. 1 cylinder and the "M" mark is centered in the timing sight hole.
3. Turn the magneto gear counterclockwise until the small white mark appears in the sight window of the magneto cover. The gear will now be in a somewhat fixed position. You will feel a point of drag or holding at this point. The impulse lever and stop will be in the position shown in figure 244.
4. Install the magneto in this position. Hold it as straight as possible. Watch the gear when installing to be sure it does not move from its position.
5. Check for correct timing by rotating the engine slowly until the impulse (a loud click) is heard. The "DC" mark should be just past the center of the sight hole.
6. Final setting can be made with a timing light, moving the magneto until the "SP" mark is centered in the sight hole.

NOTE: On engines equipped with an LP gas carburetor, the "SP" mark should be set to the left of center, lining up with the edge of the sight window when facing the engine from the front or blower side. This will give an increase in spark advance, which is permissible when LP gas fuel is used.

USING TIMING LIGHT

Follow the manufacturer's instructions for using a timing light. Basically, these steps should be used:

1. Connect one lead of the timing light to either spark plug or spark plug lead.
2. Connect one lead of the timing light to the ungrounded side of the battery.
3. Connect one lead from the timing light to a ground.
4. When the engine is running, aim the light into the timing sight hole so that the markings on the flywheel can be seen.

MAGNETO SERVICE

1. Check the magneto output by placing the end of a spark plug cable about 1/8" from the engine and cranking at normal speed.
2. If there is no spark, check the breaker points.
3. If the contact points are dirty, they may be cleaned with lacquer thinner. Wipe them dry, but make sure no particles of lint or oily film are left between the point surfaces. If pitted or burned, the points should be replaced.

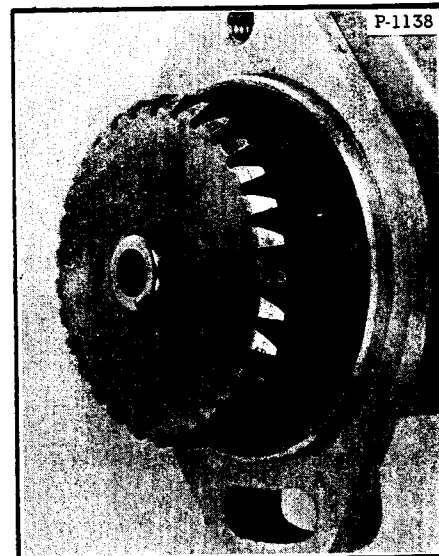

Fig. 244 Impulse Lever and Stop

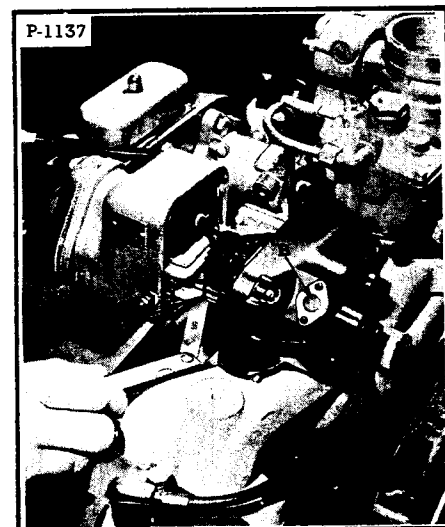
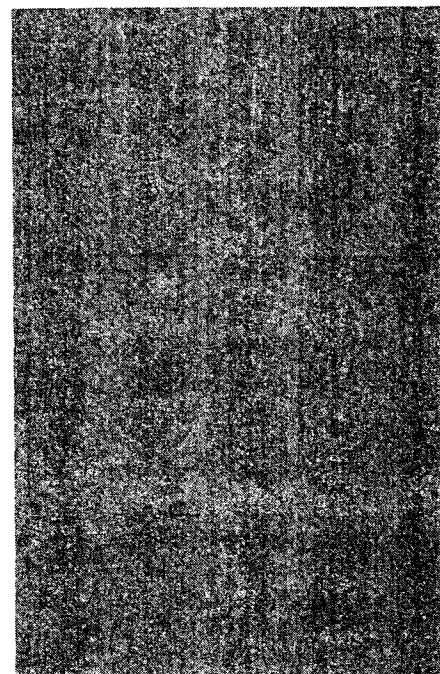
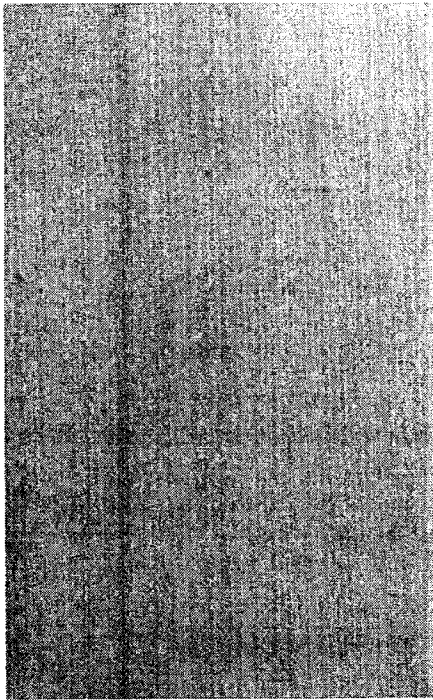

Fig. 245 Adjusting The Points





To reset the breaker points:

1. The breaker contacts should be adjusted to .015 when fully opened. Turn the flywheel until the points are wide open at the high point on the breaker cam. To adjust the points, follow these steps.
2. Loosen the two clamp screws so the contact plate can be moved.
3. Insert a small screwdriver in the adjusting slot.
4. Open or close the points by moving the plate until the opening is .015 inch (Figure 245).
5. Tighten the two clamp screws.
6. If poor ignition persists, check the condition of the coil and condenser with a good commercial tester.

The only lubrication point in the magneto is the cam wiper felt. This felt should be replaced whenever it is necessary to replace the breaker points.

ELECTRICAL SYSTEM

The alternator system used on the engine provides electrical power to charge the 12 volt battery. This system has the following basic components:

1. Permanent Field Magnet Ring
2. Alternator Stator
3. Full Wave Rectifier
4. Voltage Regulator

As the permanent field magnet ring rotates around the stator, an alternating current is induced in the primary or load winding of the stator. The current produced is approximately 30 amperes. This AC current flows to the full Wave Rectifier where it is rectified to direct current which flows to the battery.

To adjust the voltage, remove the regulator cover and connect a voltmeter to the battery terminals. Be sure that the battery load is less than the alternator output so the unit is regulating. With the alternator running at about half speed, adjust to desired voltage by turning the voltage adjustment screw (Figure 246). Turn clockwise to increase; counterclockwise to reduce.

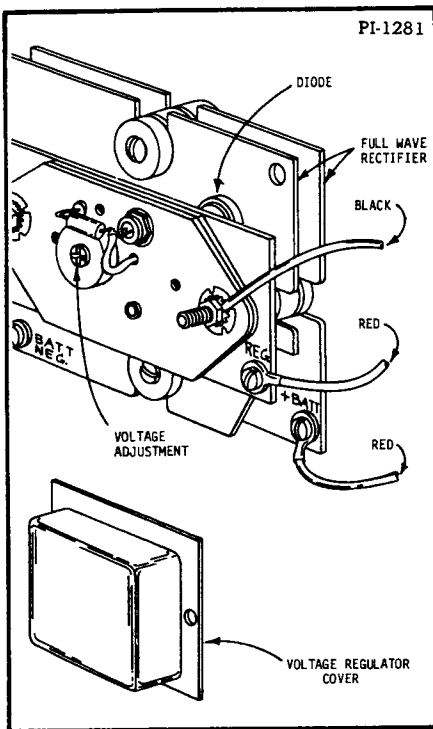
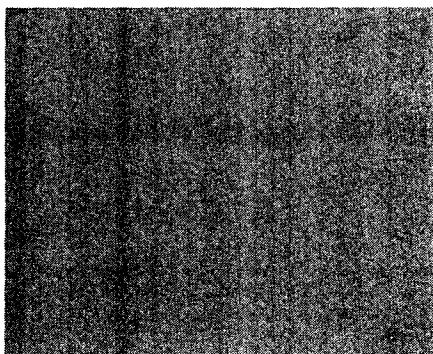

Fig. 246 Voltage Adjustment



ELECTRICAL CIRCUITRY (S/N 42806 & Below)

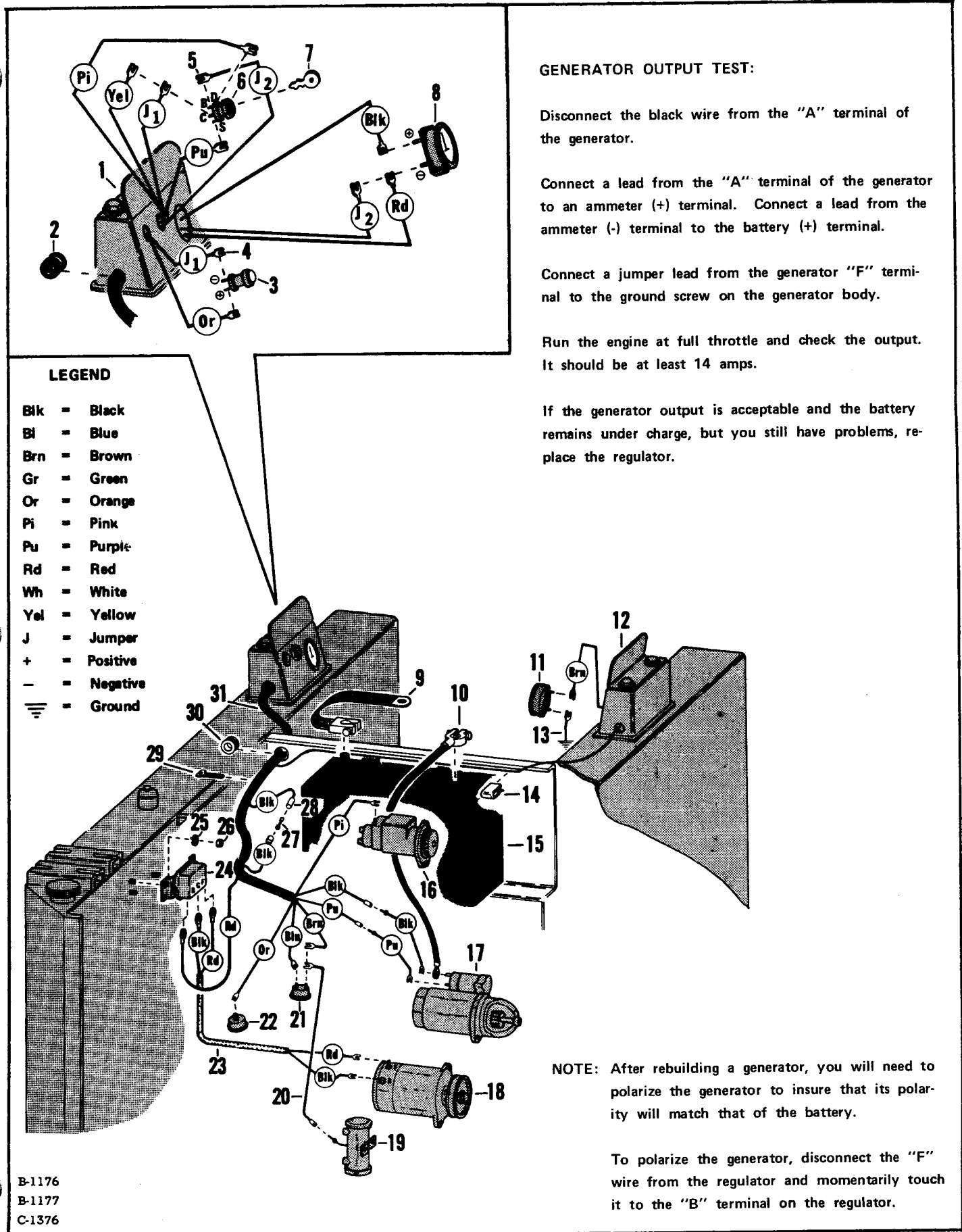

Fig. 247 Electrical Circuitry and Tests

ELECTRICAL CIRCUITRY (S/N 42807 & Up)

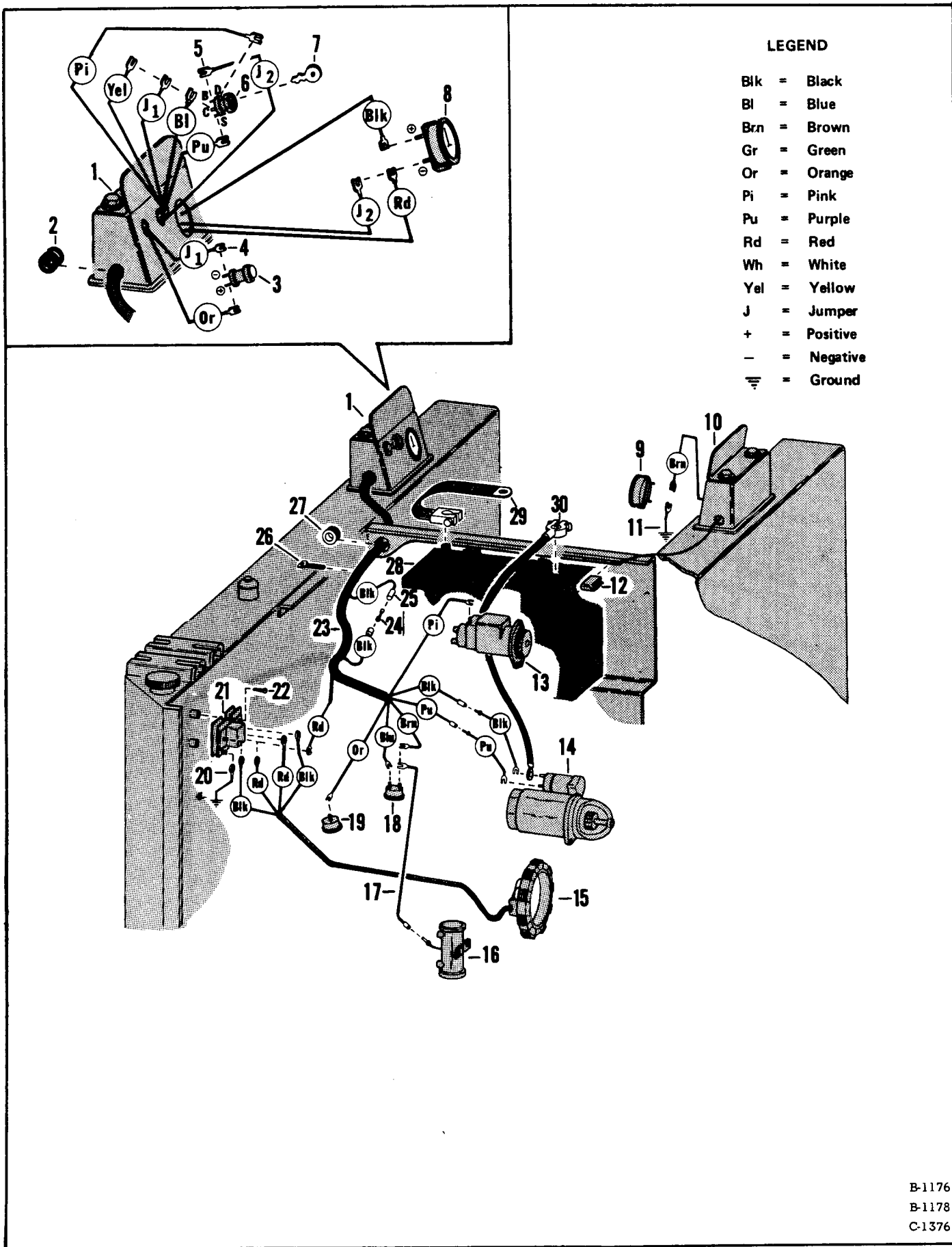

Fig. 248 Electrical Circuitry

ENGINE RECONDITIONING

To disassemble the engine:

1. Disconnect the spark plug wires.
2. Disconnect the fuel line, governor linkage and choke cable from the carburetor.
3. Remove the shrouding.
4. Remove the intake and exhaust manifolds from the engine.
5. The flywheel is mounted on a tapered shaft. Use a puller, to prevent damage to the crankshaft, when removing the flywheel.
6. Remove the magneto and governor units from the engine.
7. Disassemble the breather. Remove the gear cover and shroud mounting plate.
8. Remove the cylinder heads. Clean deposits from the cylinder bore, piston and combustion chamber.
9. Take off the valve chamber covers. Remove the retainer keys, rotators, retainers, springs and valves.
10. Push out the flywheel key. Slide the front oil seal off the shaft (Figure 249).
11. Loosen the nut on the camshaft. Remove the nut and gear from the shaft. Remove the cover plate by taking out the three cap screws. Remove the camshaft.
12. Using two large screwdrivers, pry the drive gear and key from the crankshaft.
13. At this point the oil must be drained from the crankcase.

Place the flywheel onto the crankshaft. Tip the engine forward, using the flywheel as a supporting base.

14. Remove the starter and generator.
15. Remove the oil base cap screws. Remove the oil base, oil pump intake pipe and screen, and baffle plate.
16. Remove the connecting rod caps and bearings. Push the piston and rod assemblies out of the top of the cylinder bore after cleaning the deposits from the lip.
17. Take off the closure plate assembly and remove the crankshaft from the cylinder block.
18. The valve tappets can now be taken out from the inside of the cylinder block.
19. Tip the cylinder block off the flywheel base and remove the oil pump from the front of the block.
20. Check the condition of the camshaft bearings and oil transfer bearings. If worn beyond the clearances show on page 125, replace them.

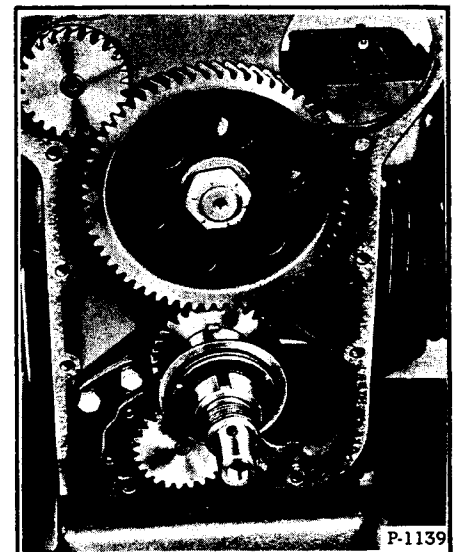
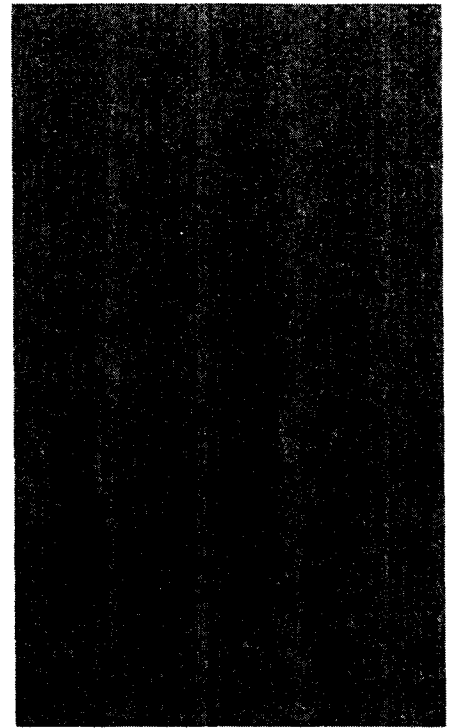
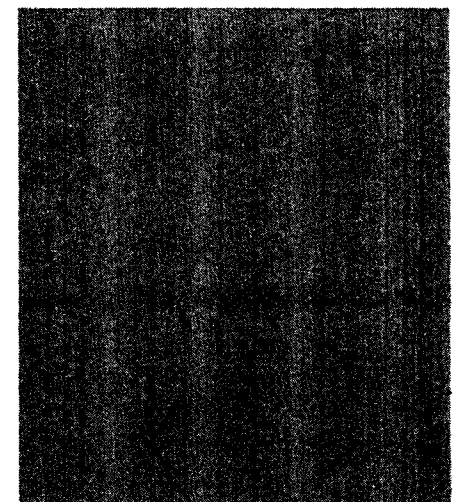
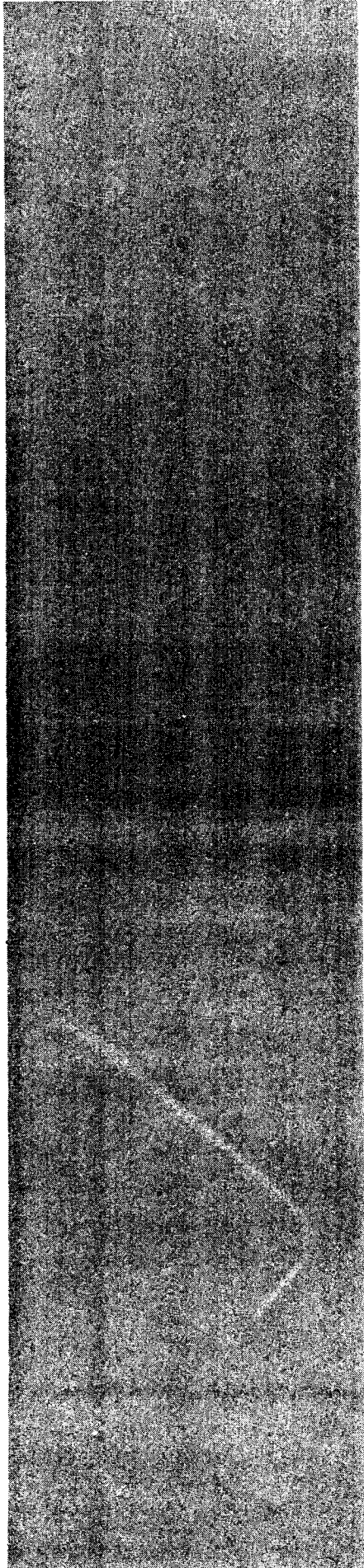

Fig. 249 Removing Front Oil Seal



- 
21. The roller bearing races in the end plate and cylinder block should not be removed unless badly scored or grooved. If replacement is necessary, drive the race out of the block with a drift punch.
 22. The roller bearings must be pressed from the crankshaft if replacement is necessary. The roller bearings used in this engine are of extra large capacity, designed to give long service life.

After cleaning all parts, inspect them carefully to determine which are reusable.

1. Cylinder Block:

If badly scored, tapered or out of round more than .005 the cylinder should be rebored.

Always bore or rebore to exactly .010, .020 or .030 over the standard bore size of 3.625.

Use an inside micrometer or dial gauge to determine cylinder wear before and during honing.

If honed to the nearest available oversize mentioned above, oversize piston and ring assemblies can be used without any additional fitting, as proper clearances will have been allowed.

Any commercial cylinder hone can be used with either a drill press or a portable electric drill. The drill press is preferable as it is important to keep the bore in alignment with the crankshaft crossbore.

Finish by washing the block with soap and water. Cover the cylinder wall with oil to prevent rust.

2. Crankshaft:

Check for score marks and metallic pick-up. Slight score marks can be cleaned with crocus cloth soaked in oil.

With a micrometer, check the journals for out-of-round. If out-of-round, replace the shaft or have the crank pin reground to .010 to .020 undersize.

Check the gear, keyway and the tapered part of the shaft for wear. If either taper or keyway is worn, replace the part.

3. Connecting Rod:

Check the bearings for wear, score marks, running clearance and side clearance. Replace if worn beyond the high limit of clearance shown on page 125.

Undersize bearings, .002 less than standard, are available for cases of moderate wear. Bearings .010 and .020 less than standard are available where grinding of the crank pin is necessary.

4. Piston:

If the cylinder block does not need reboring and the old piston is free of score and scuff marks, check the piston ring grooves and lands.

Clean up the grooves and fit new rings.

With rings in place, check with a feeler gauge. If a .005 feeler can be inserted between the ring and land, replace the piston.

Piston ring end clearance should be from .007 to .017 in the cylinder bore (Figure 250).

Never re-use old rings. Always use heavy duty type rings.

5. Piston Pins:

Very little wear occurs on the piston or in the piston bosses.

After assembly of the piston to the connecting rod, align the rod to the piston so it will be square in the cylinder bore. Use a commercial rod aligner.

6. Valves, Seats and Guides: (Figure 251)

Check the clearance of old valve stems in the guides. If worn, replace the guides and install new valves.

The valve seats are eatonite or stellite. The seating surfaces should be held as nearly as possible to 1/32" in width. Seats with more than 1/16" seating surface should be reconditioned with 45° and 15° cutters to form the proper seat.

Valve seats can be replaced only by using special tools. Follow instructions given by the tool manufacturer when replacing these seats.

7. Oil Pump:

The oil pump is a positive gear type. Pressure is adjusted at the factory. It should not be necessary to change this adjustment.

A sudden drop in oil pressure may be caused by dirt or foreign particles in the pump check valve. Remove the screw (Figure 252) and take out the spring and valve. Inspect and clean the seat and valve. Reinstall the valve, spring and adjusting screw.

Turn the adjusting screw the same distance into the pump body as before it was removed. If it should be necessary to readjust the oil pressure, turn the screw to the left (counterclockwise) to decrease pressure and to the right (clockwise) to increase pressure. Seal the screw with Permatex or equivalent when adjustment is completed.

When the oil pump is installed, the oil pump drive gear should be checked for backlash and for alignment with the drive gear.

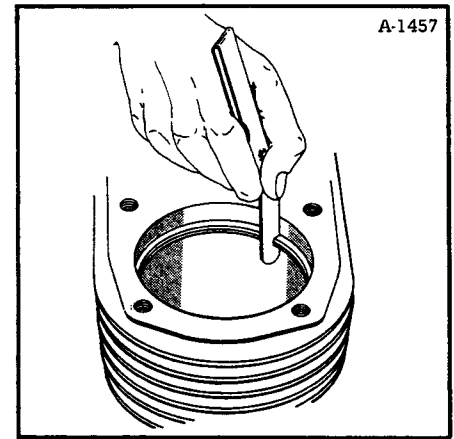

Fig. 250 Ring End Clearance

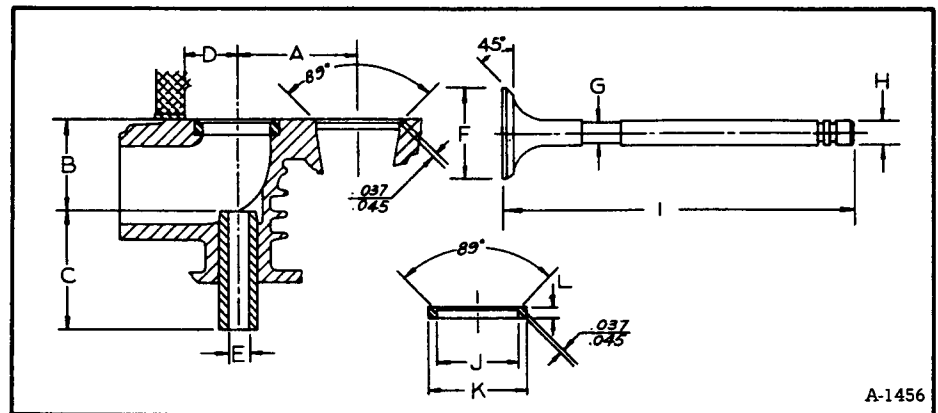

Fig. 251 Valves, Seats and Guides

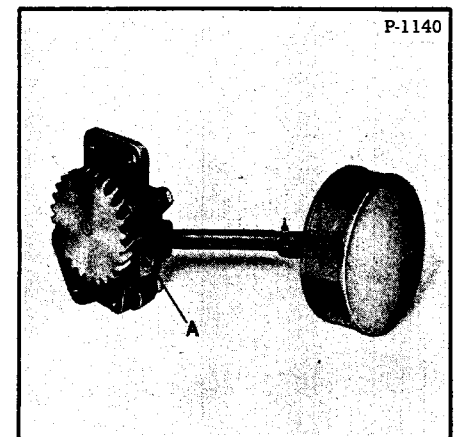
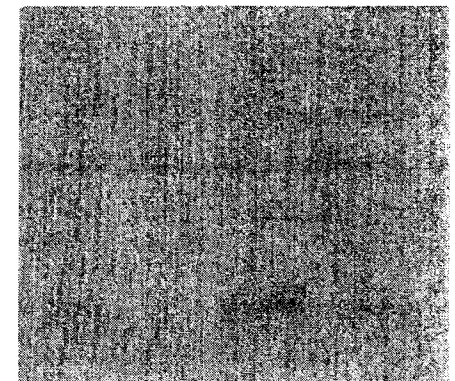

Fig. 252 Oil Pump



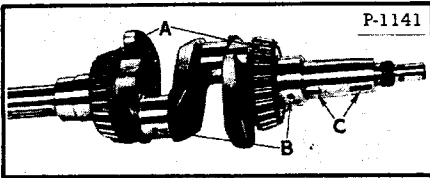

Fig. 253 Roller Bearings

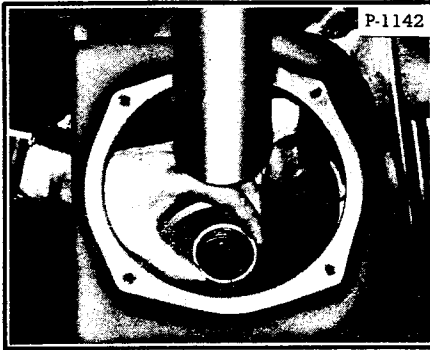

Fig. 254 Pressing in Transfer Sleeve

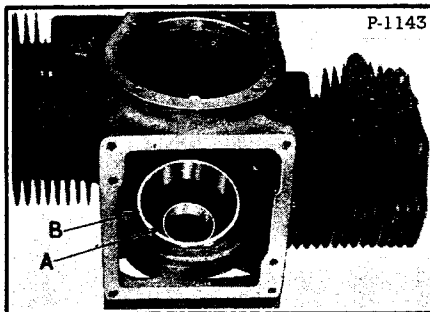

Fig. 255 Pressing in Bearing Race

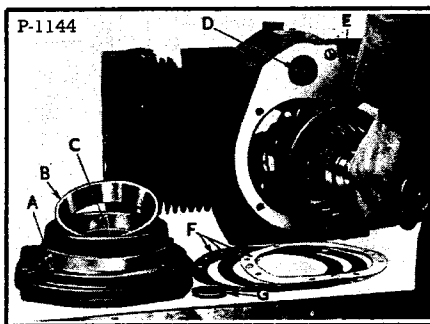

Fig. 256 Installing Crankshaft

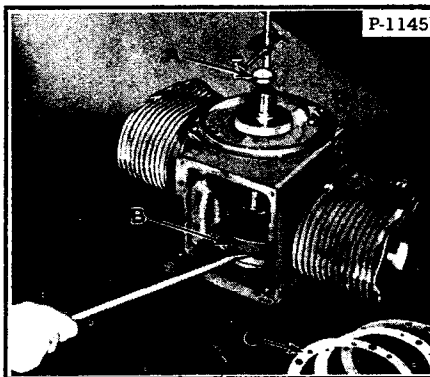

Fig. 257 Checking End Clearance

To reassemble the engine:

1. Crankshaft and camshaft:

Press the roller bearings onto the crankshaft (Figure 253).

With a close fitting pilot or arbor, press the transfer sleeve into the cylinder block (Figure 254). Be sure the oil holes in the sleeve line up with the block oil holes.

Press the roller bearing race into the cylinder block (Figure 255).

Press the camshaft bearings into place with a pilot shaft.

From the inside of the cylinder block, position the valve tappets into their guides.

Slide the camshaft in from the front of the block.

The welch plug (Figure 256, Item G) can now be pressed into the camshaft opening at the rear of the cylinder block.

The second oil transfer sleeve and roller bearing race can now be pressed into the rear closure plate (Figure 256).

The crankshaft can now be installed into the cylinder block assembly (Figure 256).

Install an optimum number of shim gaskets on the rear closure plate and bolt this assembly to the cylinder block. Be sure the oil passages line up.

WARNING

Do not rotate the closure plate.

The crankshaft should now be checked for end clearance.

2. Crankshaft End Clearance:

Use a dial indicator to check for accuracy when adjusting for crankshaft end clearance.

Position the indicator to align with the end of the crankshaft at the closure plate end of the engine (Figure 257).

Use a soft hammer and drive the crankshaft toward the front of the engine. Position the indicator and set the dial on "0".

Insert a bar under the crankshaft counterweight and pry the shaft toward the closure plate side (Figure 257).

The reading shown on the indicator will be the crankshaft end clearance. The proper gaskets can now be added or subtracted as necessary to obtain the .0035 to .0055 end clearance. These gaskets and shims are available in .005, .007 and .020 sizes.

When installing shim gaskets, the .020 size (steel shim) should have a minimum of .014 on both sides. Do not use a steel shim if the gasket stack is less than .048 inch.

3. Rear Oil Seal:

WARNING

When installing the rear oil seal, be very careful that the lip of the seal is not damaged in any way. Damage to the knifelike edge will cause an oil leak, as will any foreign matter.

Slide the seal onto the crankshaft. Tap the seal into the closure plate with a close fitting driver.

4. Crankshaft Gear, Oil Pump and Cover Plate:

Position the Woodruff key in the crankshaft.

Slide the gear onto the shaft and drive it into position using a brass drift pin.

Set the oil pump into position and bolt it to the block.

Apply grease to the cover plate. Position the gasket on it and bolt it to the block with the three cap screws (Figure 258).

5. Camshaft Gear and Timing:

Place the Woodruff key in the camshaft and rotate the cam so the key position is at 9 o'clock (Figure 259).

Turn the crankshaft to place the drive gear with its punch marked tooth at 12 o'clock position (Figure 259).

The single punch mark, "B", on the crankshaft gear must center on the two punch marks on the cam gear (Figure 260). Slide the cam gear into position and secure it with 40 ft. lbs. torque on the cam nut. Hold the cam gear with a screwdriver inserted through a hole in the gear and wedged against a screw head on the cover plate.

6. Piston Ring and Rod Assembly:

Assemble the pistons to the connecting rods. Secure the piston pins with retainer rings. Always use new retainers. Be sure the retainers are fully engaged in the grooves in the piston pin bosses.

Before putting rings on the piston, try them in the cylinder bore to be sure they have an end clearance of .007 to .017 inch (Figure 261).

Insert the oil ring expander (in the bottom groove) with the drainage notches down (Figure 262). Install the two-turn chrome steel rail. Insert the cast iron oil ring in the groove above the chrome steel rail.

Place the expander ring into the second groove. Install the steel rail into the groove. Install the cast iron ring above the steel rail. The side of the ring marked with dots or marked "TOP" must be up.

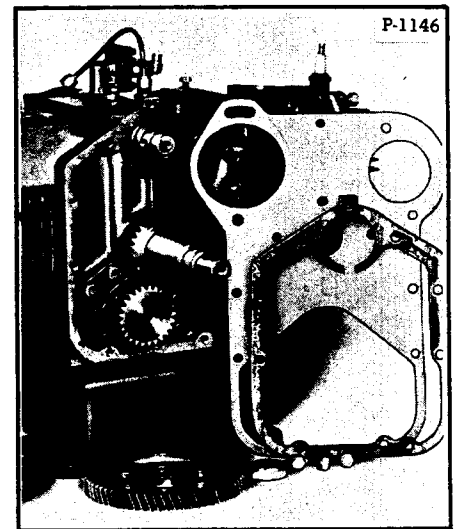

Fig. 258 Installing Cover Plate

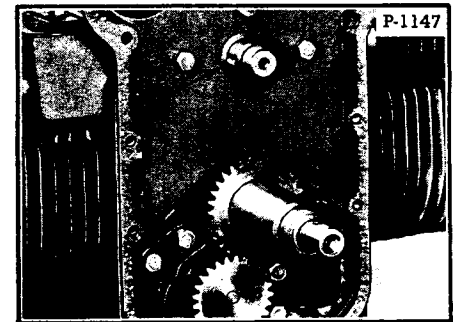

Fig. 259 Gear Timing

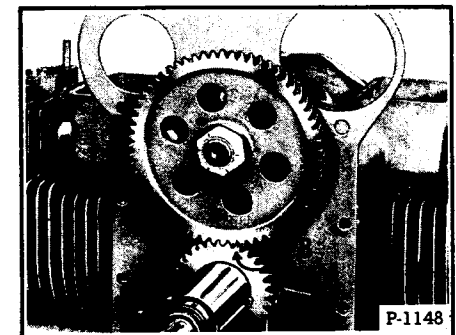

Fig. 260 Installing Cam Gear

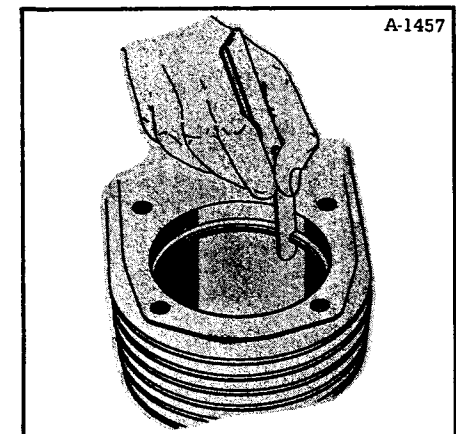

Fig. 261 Ring End Clearance

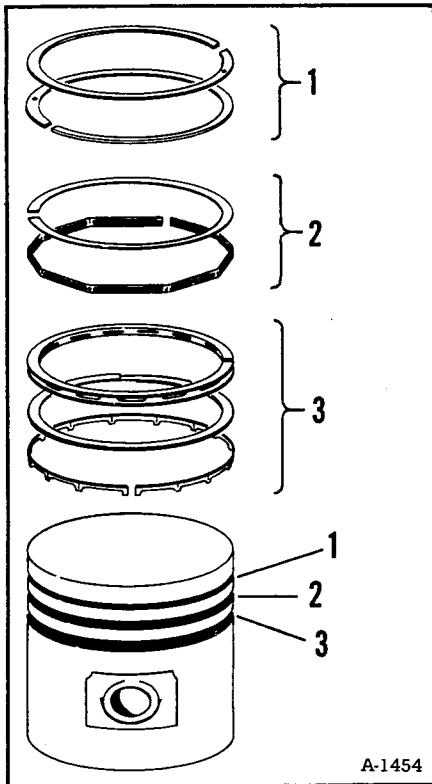

Fig. 262 Installing Rings

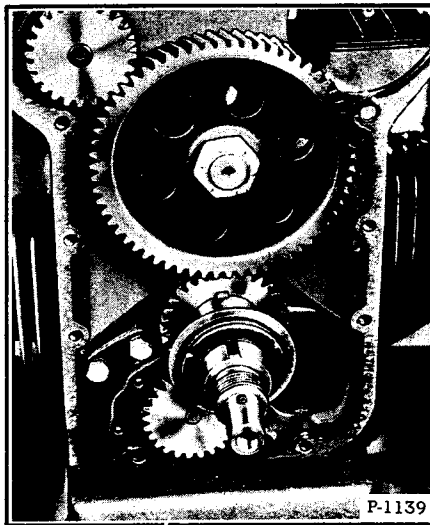
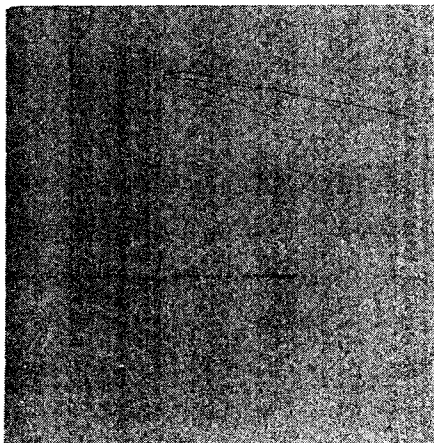

Fig. 263 Front Oil Seal



Install the top compression ring with the marked side up.

NOTE: Always stagger the ring gaps.

7. Piston Assembly and Installation:

Place the flywheel loosely on the crankshaft and tip the engine over, using the flywheel as a supporting base.

Separate the rod caps from the piston assemblies and install the rod bearings.

Oil the rod bearings, piston rings and crank pins.

Space the ring gaps so they are not in line. Insert the piston into the cylinder bore. Use a ring compressor to protect the rings during installation. Push the piston into the cylinder bore, at the same time aligning the connecting rod to the crank pin.

Assemble the connecting rod cap and cap screws to the connecting rod. Make sure the marks on the connecting rod and cap line up and face the flywheel end of the engine.

Tighten the cap screws to 40 ft. lbs. torque. Back off the screws and retighten to 35 ft. lbs. torque. This will assure a tight fit of the rod to the crankshaft and avoid the possibility that the screws may be tight in the threads while the rod is still loose on the shaft.

8. Oil Pump and Base:

Thread the intake pipe into the oil pump.

Install one oil pan gasket, oil baffle plate and second gasket to the cylinder block.

Attach the strainer clip to the intake pipe and install the strainer.

Position the base on the cylinder block and attach with four cap screws. Tighten the screws to 45 ft. lbs.

Tip the engine onto its base and remove the flywheel.

9. Front Oil Seal and Gear Cover: (Figure 263).

Slide the seal assembly onto the crankshaft. Align the seal slot with the crankshaft gear key.

Place the gasket on the gear cover. Position the cover onto the engine.

Install the housing support plate and starter brackets with the gear cover screws.

10. Flywheel:

Install the flywheel Woodruff key into the crankshaft.

Slide the flywheel onto the shaft.

Install the flywheel lock nut. Insert a bar between the flywheel fins and tighten the lock nut to 130 ft. lbs. torque.

11. Installing and Adjusting Valves:

Install the valve springs, spring retainers (or rotators) and valves.

Using a valve spring compressor, compress the valve springs and install the retainer keys.

Be sure the valves are firmly seated in the block. Crank the engine until the piston is at top dead center. Proceed to adjust the valve clearance. Set the exhaust valve at .015; intake at .008. Repeat for other side.

Install the studs, gaskets and covers on the valve chambers. Use plain brass washers and 1/4" nuts to hold the covers in place.

12. Crankcase Breather: (Figure 264)

Place the spring steel reed and stop plate (with the outside ends away from the reed) in position on the gear cover.

Install the nut on the end of the stud and thread the stud into the gear cover. Draw down the holding nut to hold the breather reed and plate in proper position.

Install the gasket, breather body and cover. Fasten with the acorn nut.

13. Cylinder Heads:

New head gaskets should be placed onto the head and held in place with the cap screws.

Be sure the washers are in place before the cap screws are positioned in the head.

Tighten the head bolts evenly and in sequence (Figure 265) to 50 ft. lbs. torque.

14. Governor and Magneto:

Position the gasket and governor assembly on the back plate. Fasten in place with the long bolt at the bottom. Install the lock washer and nut on the governor side.

Attach the oil line from the top oil gallery to the governor assembly. Refer to Governor Section (Page 105) for adjustment.

Install the gasket on the magneto flange. Refer to Ignition Timing (Page 113) for correct installation.

15. Manifolds:

Soak the manifold gaskets in water and place them into position on the engine block.

Position the manifolds onto the engine. Install two 5/16" cap screws in the outside bolt holes.

Place a heavy flat washer on the manifolds at the center bolt hole. Position the side baffles and install the 5/16" cap screws using a lockwasher and flat washer at the center hole.

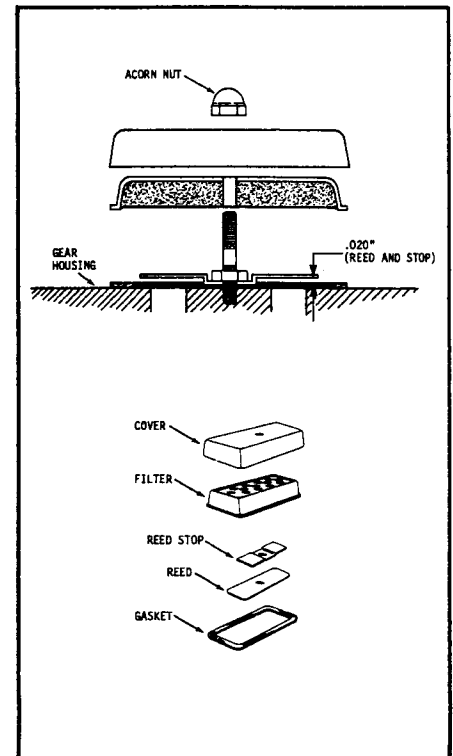

Fig. 264 Crankcase Breather

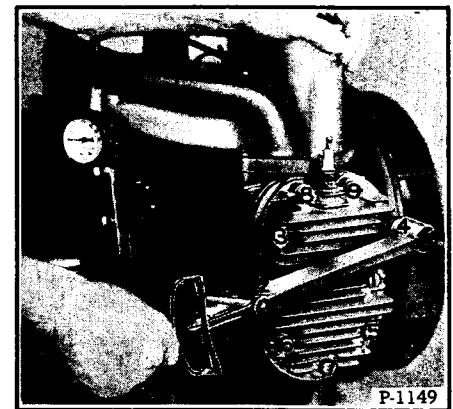
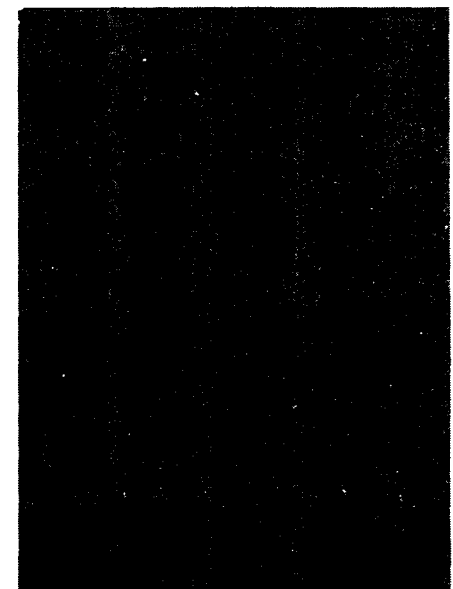

Fig. 265 Tightening Cylinder Head



Final tightening of these screws may be done after the front shroud is installed.

Make the carburetor and governor connections.

16. Spark Plugs and Cables:

Install new spark plugs in the heads. Use new gaskets. Tighten to 27 ft. lbs. torque.

Attach the high tension cables to the magneto and spark plugs. Fasten the cable clamps in place on the intake manifold.

17. Blower Housing and Rotating Screen:

Install the blower housing and screen assembly.

18. Final Adjustments:

Make final adjustments, as needed, for ignition, carburetion, governor and speed control.

TECHNICAL DATA (Kohler)

RUNNING CLEARANCES

Cylinder Bore	3.625
Crankshaft to main bearing running clearance002 - .0035
Main bearing to block or closure plate0025 - .0055 Interference
Closure plate to block001 - .005
Crankshaft end play0035 - .0055 (.004 desired)
Connecting rod to crankpin running clearance0003 - .0023
Connecting rod side play on crankpin003 - .007
Connecting rod to connecting rod bushing0015 - .0050 Interference
Connecting rod bushing to wrist pin0001 - .0006
Wrist pin to piston boss0001 - .0003 Selective
Ring side clearance, top ring0025 - .0045
Ring side clearance, middle ring0025 - .0045
Ring side clearance, oil ring002 - .0035
Ring end gap010 - .020
Camshaft to bearing running clearance (Front)001 - .003
(Rear)001 - .003
Camshaft bearing to bearing housing (Front)0035 - .0075 Interference
(Rear)0035 - .0075 Interference
Camshaft end play017 - .038
Valve clearance intake (cold)006 to .008 (.008 nominal)
Valve clearance exhaust (cold)015 to .017 (.015 nominal)
Spark plug gap025 (Gasoline), .018 (Gas)
Tappet in block0003 - .0018
Valve, stem in guide (Exhaust)002 - .0035
(Intake)0005 - .002
Guide in block0005 - .002 Interference
Exhaust valve seat in block0025 - .0045 Interference
Crankshaft gear to crankshaft001 Interference to .0005 Clearance
Camshaft gear to camshaft0005 - .002
Output shaft seal to closure plate0015 - .0085 Interference
Magneto pilot001 - .005
Governor pilot000 - .012
Governor gear to governor shaft0005 - .0013 Interference
Piston to cylinder bore clearance (top thrust face)0005 - .0015

Crankshaft standard wearing surface

Main journal	2.250
Rod journals	1.875
Transfer sleeve journals	2.125

OIL PUMP

Drive gear to shaft0005 - .0015 Interference
Pumping gears to shafts0005 - .0015 Interference
Pump body and plate to shafts001 - .0025
Pumping gear end clearance002 - .005
Pumping gear radial clearance0022 - .0030
Oil Pressure 1800 - 3600 R.P.M. (any load)35 - 60 psi

MAGNETO IGNITION

Magneto breaker gap015
Spark, run	22 deg. BTDC
Spark, impulse	2 deg. BTDC

TORQUE VALUES

Connecting Rod screw35 ft. lb.
* Cylinder Head Screw50 ft. lb.
Closure Plate Screw50 ft. lb.
Camshaft Nut40 ft. lb.
Flywheel Nut	130 ft. lb.
Spark Plug27 ft. lb.
Oil Pan Screw45 ft. lb.

* Lubricate with grease at assembly.

NOTE: Always use torque wrench on above parts.

ONAN ENGINE SERVICE

CRANKCASE BREATHER (Figure 267)

Lift off the rubber breather cap. Carefully pry the valve from the cap; or press hard, with both thumbs on top of the cap and your fingers below, to release the valve from the rubber cap. Wash the fabric flapper type check valve in fuel. Dry and install it, with the perforated disc toward the engine.

GOVERNOR & SPEED CONTROL

The governed engine speed is 3000 RPM maximum, no load.

Before making a governor adjustment, run the engine about 15 minutes to reach the normal operating temperature.

The speed at which the engine operates is determined by the tension applied to the governor spring. Increasing spring tension increases engine speed. Decreasing spring tension decreases engine speed.

CARBURETOR ADJUSTMENT

To adjust the idle jet needle (Figure 268), turn the idle adjusting needle IN until the engine loses speed. Then turn it OUT until the engine runs smoothly. A hunting condition at no-load can sometimes be corrected by an idle adjustment.

NOTE: Make the adjustment when the engine is running at normal operating temperature and no-load.

CARBURETOR RECONDITIONING (Gasoline)

Carburetor maintenance should consist of regular cleaning. Some gasolines have a tendency toward formation of gum deposits inside the carburetor which can usually be removed by soaking in alcohol or acetone. A fine, soft wire may be used to clean the jets.

Figure 269 shows the carburetor breakdown. When reconditioning the carburetor always use a repair kit. Refer to the Bobcat Parts Book.

Be sure the float is not damaged. If necessary to reset the float lever, use a small screwdriver to bend the lip of the float. With the carburetor casting inverted and the float resting lightly against the needle in its seat, there should be 5/16" (1/4" with styrafoam plastic float) clearance between the bowl cover gasket and the free end of the float (side opposite the needle seat) (Figure 268).

TEMPERATURE	VISCOSITY
Below 0° F	SAE 5W
0° F to 30° F	SAE 10W
30° F to 90° F	SAE 30
Above 90° F	SAE 50

Fig. 266 Oil Specifications

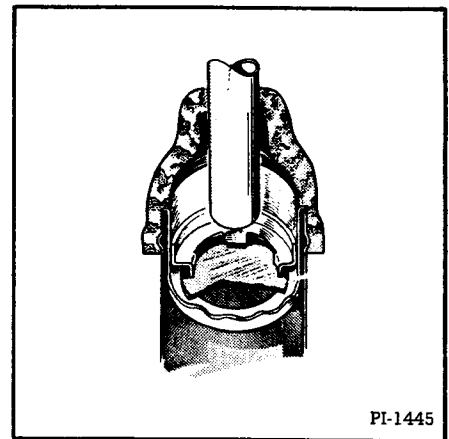

Fig. 267 Crankcase Breather

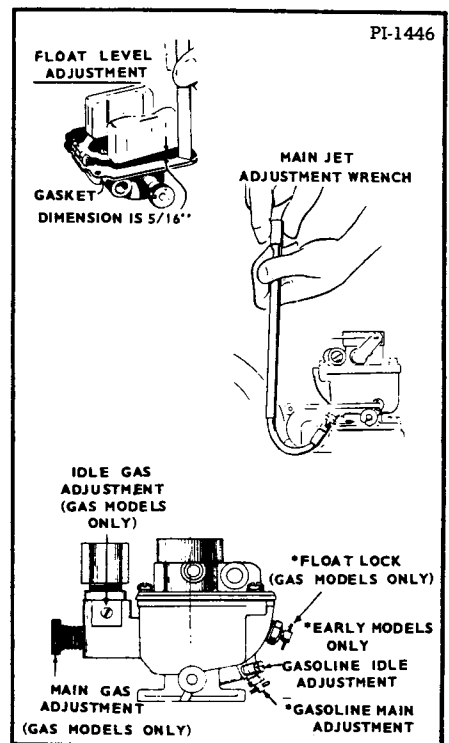

Fig. 268 Carburetor Adjustment

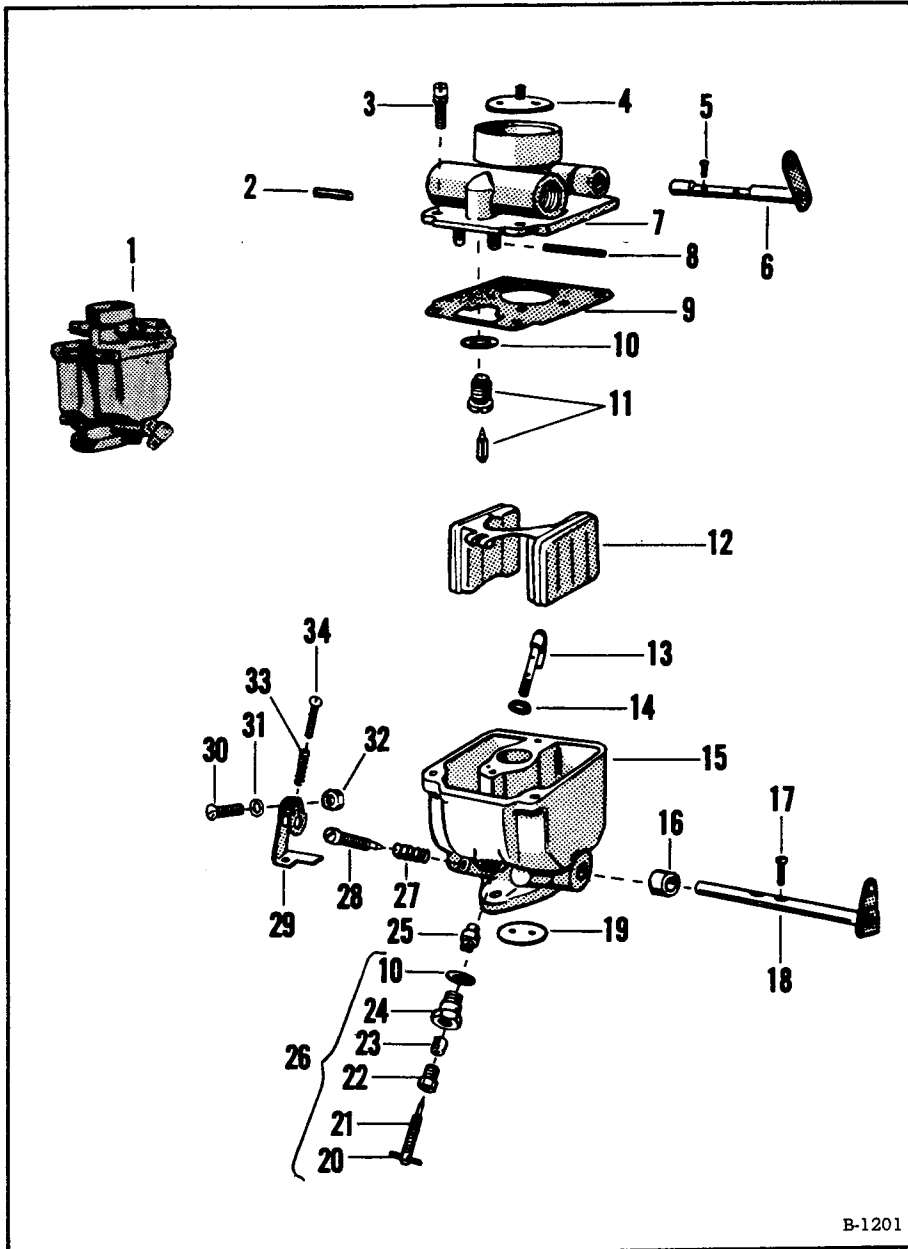

Fig. 269 Gasoline Carburetor Breakdown

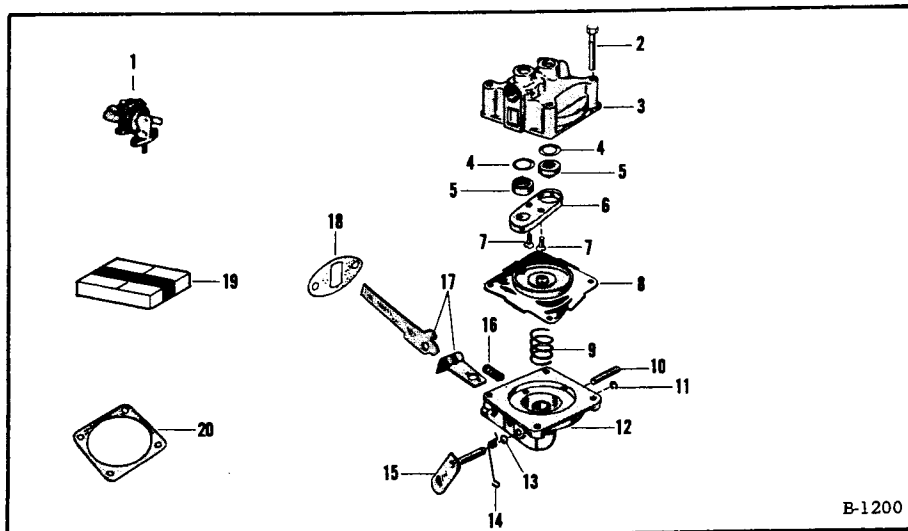

Fig. 270 Fuel Pump Breakdown

FUEL PUMP

A diaphragm type fuel pump is used (Figure 270). If fuel does not reach the carburetor, check the fuel pump before dismantling it. The pump can be checked by disconnecting the fuel line at the carburetor, cranking the engine slowly, and observing whether fuel comes from the line at the carburetor. If there is enough fuel in the tank, and the line between the tank and pump is clear but the pump fails, repair or replace it. Failure of the pump is usually due to a leaking diaphragm, valve or valve gasket, a weak or broken spring, or wear in the drive linkage.

If you choose to repair the pump rather than replace it, use a repair kit.

NOTE: Always return the handpriming lever all the way inward so the priming lever does not prevent normal pump operation.

Gasoline diluted oil may indicate a faulty fuel pump.

CARBURETOR RECONDITIONING (LP Gas)

To disassemble the carburetor:

1. With the carburetor inverted, loosen the check nut (Figure 271, Item 3) and remove the main adjustment screw (Item 2) and check nut from the fuel metering block. Remove the fuel block screws, fuel block (Item 4) and gasket (Item 19).
2. Remove the adapter plate screws and lockwashers (Items 5, 6, 20 & 21). Remove the adapter plate (Item 7) and gasket from the throttle body.
3. Remove the idle needle valve (Item 15) with its spring from the throttle body.
4. Remove the throttle screws (Item 17) and throttle plate (Item 18). Remove the throttle shaft and lever assembly (Item 12). Remove the seal retainers (Item 11) with their seals (Item 10).

WARNING

Never use a wire or drill to clean out the jets.

Thoroughly clean all metal parts, using a special carburetor cleaner. Rinse in solvent. Blow out all channels in the casting with compressed air. Reverse the air flow through each passage to insure removal of all dirt particles.

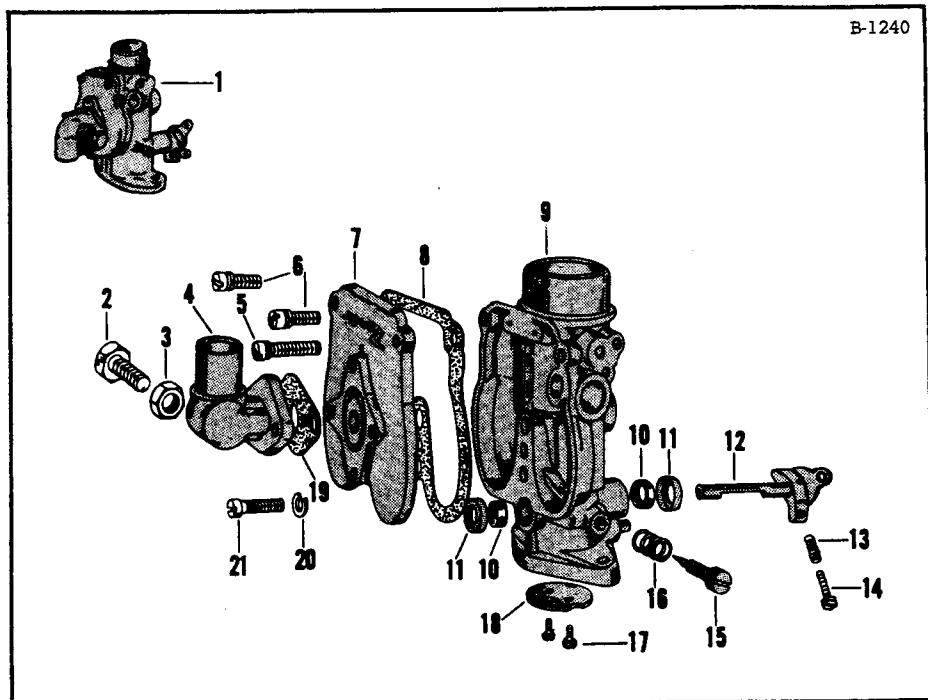

Fig. 271 LP Carburetor Breakdown

Inspect all parts and replace any that are damaged or worn. Always use a repair kit. For the correct repair kit to use, see your Bobcat Parts Book.

To reassemble the carburetor:

1. Place the adapter plate gasket (Item 8) on the throttle body and attach the adapter plate (Item 7) to the throttle body using two short screws and lockwashers (Item 6). Place a lockwasher onto the medium length screw (Item 21) before installing it. The long screw (Item 5) goes into the raised portion of the adapter. Tighten the screws uniformly.
2. Place the metering block gasket onto the adapter and attach the fuel metering block (Item 4). Assemble the check nut (Item 3) onto the main adjustment screw (Item 2). Thread the screw into the fuel block until the screw just contacts the seat. Back out the screw two full turns and tighten the check nut.
3. Place the spring on the idle needle valve (Item 15) and assemble the idle needle valve into the throttle body. Turn the needle valve IN lightly against its seat, then back it OUT one turn.
4. Place the seals (Item 10) into their retainers and insert them into the throttle shaft counterbores from opposite sides. Insert the throttle shaft (Item 12) and loosely attach the throttle plate (Item 18) to the throttle shaft with its screws. Make sure the throttle plate and shaft are assembled in the same way as before disassembly. Close the throttle. Align for best closing, then tighten the screws.

VAPORIZER - PRIMARY REGULATOR SERVICE

To service the vaporizer - primary regulator, see page 81.

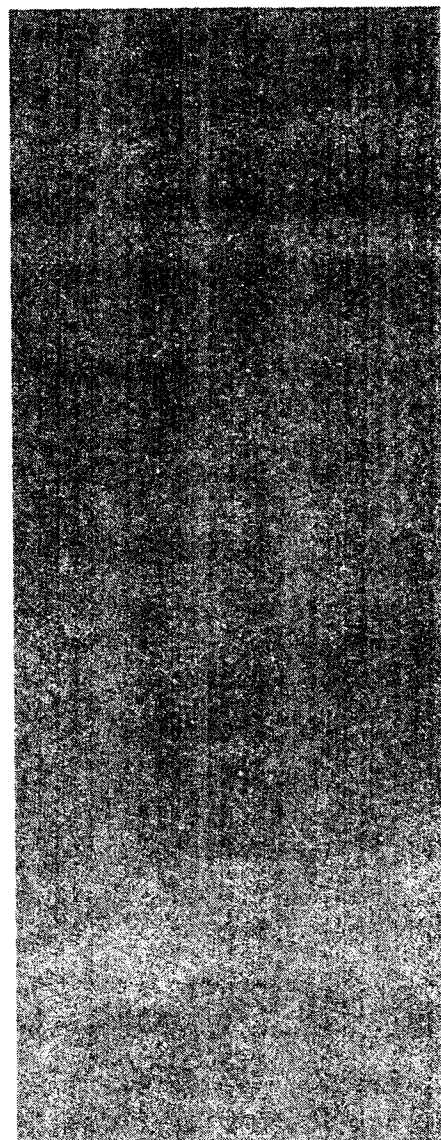

VALVE SYSTEM (Figure 274)

Properly-seated valves are essential to good engine performance. The aluminum cylinder heads are removable for valve servicing. Do not use a pry to loosen the cylinder head, rap sharply on the edge with a soft-faced hammer, taking care not to break any cooling fins. A conventional-type valve spring lifter may be used when removing the valve spring locks, which are of the slip type. Clean all carbon deposits from the cylinder heads, piston tops, valves, guides, etc. If a valve face is burned or warped, or the stem worn, install a new valve.

Worn valve stem guides may be replaced from inside the valve chamber. Valve locks are split, tapered-type, the smaller diameter of which must face toward the valve head. Tappets are also replaceable from the valve chamber, after first removing the valve assemblies.

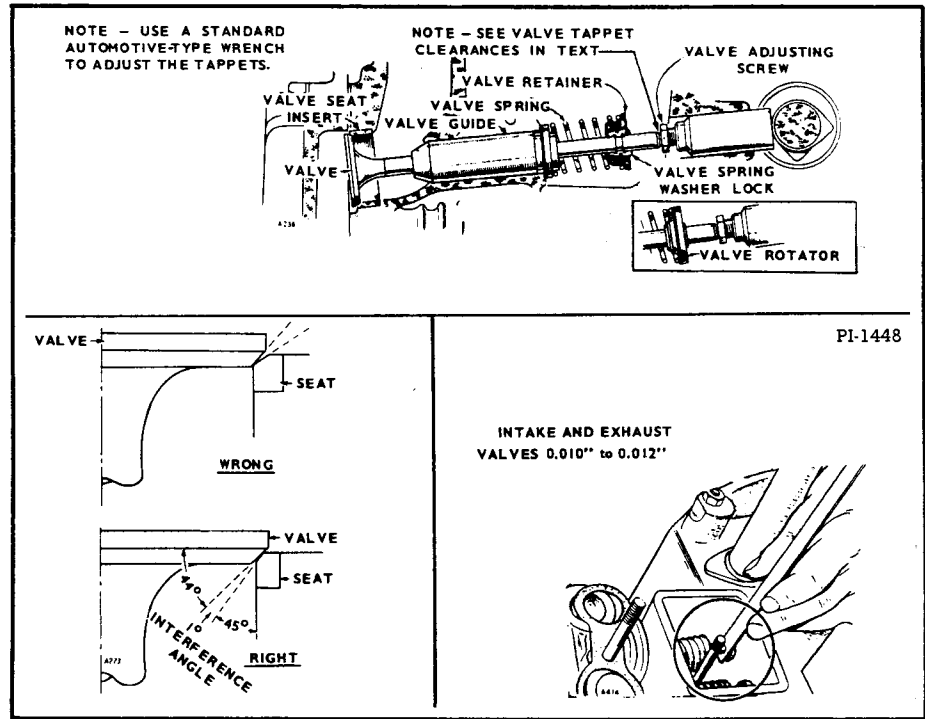

Fig. 272 Valves, Seats and Guides

The valve face angle is 44° . The valve seat angle is 45° . This 1° interference angle results in a sharp seating surface between the valve and the top of the valve seat. The interference angle method of grinding valves minimizes face deposits and lengthens valve life.

The valves should not be hand lapped, if at all avoidable, since the sharp contact may be destroyed. This is especially important where stellite-faced valves and seats are used. Valve faces should be finished in a machine to 44° . Valve seats should be ground with a 45° stone, and the width of the seat band should be $1/32''$ to $3/64''$ wide. Grind only enough to assure proper seating.

Remove all grinding compound from engine parts and place each valve in its proper location. Check each valve for a tight seat, using an air pressure testing tool. If such a tool is not available, make pencil marks at intervals across the valve face and observe if the marks rub off uniformly when the valve is rotated part of a turn against the seat.

Lightly oil the valve stems and assemble all parts removed.

The positive-type valve rotocaps prolong valve life and decrease valve repairs. When functioning properly, the valve is rotated a fraction of a turn each time it opens. While at open position, the valve must rotate freely, but in only one direction. If rotocaps are faulty, install new rotocaps.

TAPPET ADJUSTMENT

The engine is equipped with adjustable tappets. To make a valve adjustment, remove the covers. Crank the engine over slowly by hand until the left-hand intake valve (when facing the flywheel) opens and closes. Continue about $1/4$ turn until the mark on the flywheel and the TC mark on the gear cover are in line. This should place the left-hand piston at the top of its compression stroke, the position it must be in to get proper valve adjustment for the left-hand cylinder. Clearances are shown in Fig. 272 and the Table of Clearances. For each valve, the thinner gage (minimum) should pass freely between the valve stem and valve tappet, but the thicker gage (maximum) should not (Fig. 275).

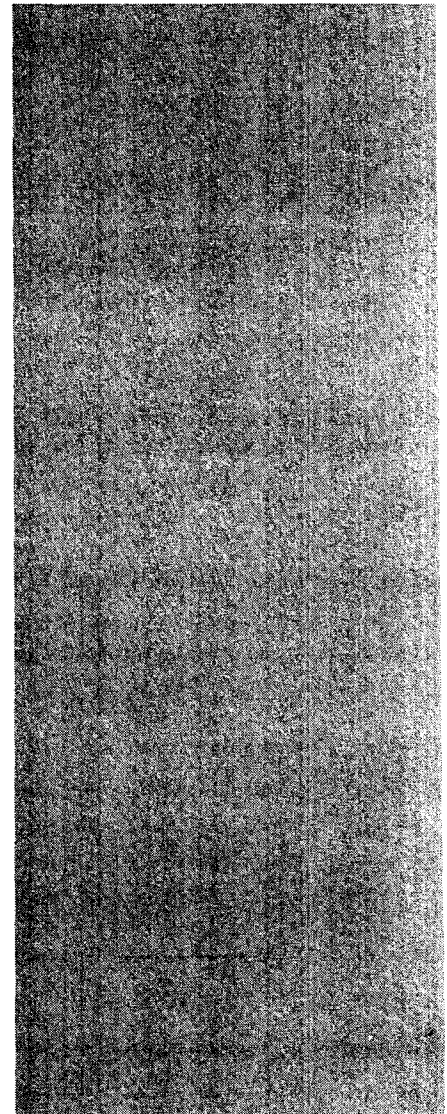

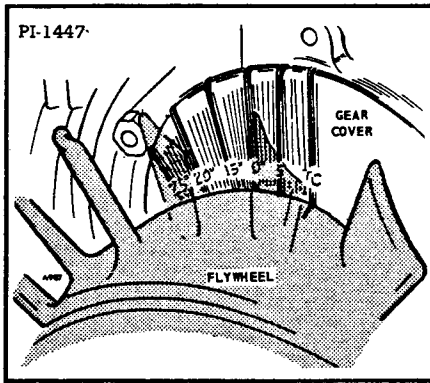

Fig. 273 Ignition Timing Marks

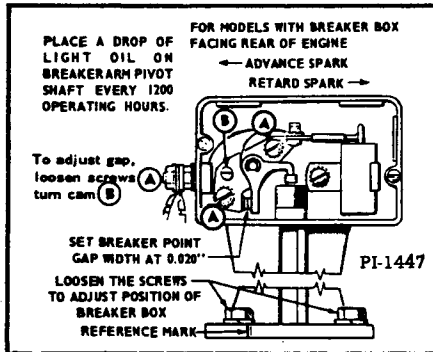

Fig. 274 Ignition Timing

To correct the valve clearance, simply turn the adjusting screw as needed to obtain the right clearance. The screw is self-locking, and will stay where set.

To adjust the valves on the right-hand cylinder, crank the engine over one complete revolution and again line up the mark on the flywheel and the TC mark on the gear cover. Then follow the adjustment given for the valves of the left-hand cylinder.

IGNITION TIMING

Spark advance is 25°. Remove the sheet metal plug from the top of the engine air housing. Note the timing marks stamped on the gear cover (Figure 272).

1. Remove the cover from the breaker box. If the timing is very far off, attain an approximate setting by loosening the mounting screws and shifting the breaker box to align the witness marks on the cylinder block and breaker box (Figure 273).
2. Crank the engine over slowly by hand in the direction of crankshaft rotation until the witness mark on the flywheel and the TC mark on the gear cover are exactly in line.
3. Adjust the ignition breaker point gap width to .020" at full separation (Figure 274).
4. Turn the flywheel to the left, against crankshaft rotation, until the timing mark is about two inches past the 25° mark on the gear cover.
5. Turn the flywheel slowly to the right and note whether the ignition points just separate when the mark on the flywheel aligns with the 25° mark on the gear cover.

If the mark aligns as the points break, timing is correct.

If they do not, loosen the breaker box mounting screws and shift the whole breaker box assembly slightly toward the No. 1 cylinder to retard the timing (points breaking too soon); shift it slightly away from the No. 1 cylinder to advance the timing (points not breaking soon enough).

Tightening the breaker box mounting screws securely after making the adjustment.

SPARK PLUGS

The spark plug gaps should be .025 in. for gasoline and .018 for LP gas.

Torque the spark plugs to 25 - 30 ft. lbs. when installing.

ELECTRICAL CIRCUITRY

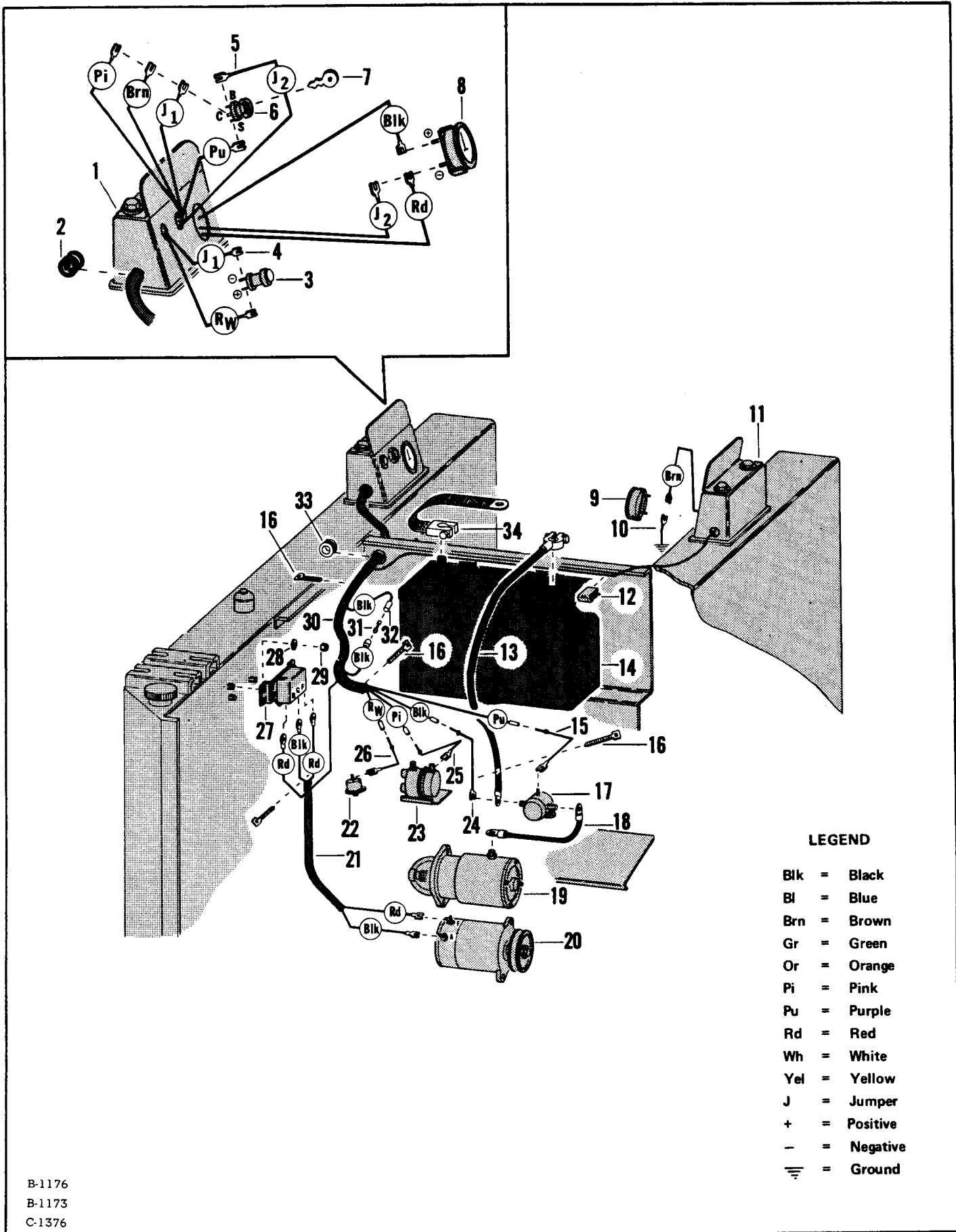

LEGEND

- Blk = Black
- Bl = Blue
- Brn = Brown
- Gr = Green
- Or = Orange
- Pi = Pink
- Pu = Purple
- Rd = Red
- Wh = White
- Yel = Yellow
- J = Jumper
- + = Positive
- = Negative
- ⏏ = Ground

B-1176
B-1173
C-1376

Fig. 275 Electrical Circuitry

ENGINE RECONDITIONING

To disassemble the engine:

1. Gear Cover:

After removing the mounting screws, tap the gear cover gently with a soft faced hammer to loosen it.

2. Governor Cup:

With the gear cover removed, the governor cup can be taken off after removing the snap ring from the camshaft center pin. Catch the flyballs while sliding the cup off.

3. Timing Gears:

If replacement of either the crankshaft gear or the camshaft gear becomes necessary, always install both gears new.

To remove the crankshaft gear, first remove the snap ring, then attach a gear pulling ring using two No. 10-32 screws. Tighten the screws alternately until both are tight. Attach a gear puller to the puller ring and proceed to remove the gear (Figure 276).

The camshaft gear is pressed on and keyed to the camshaft. The camshaft and gear must be removed as an assembly, after first removing the crankshaft gear lock ring and washer. Before removing the camshaft and gear assembly, remove the cylinder head and valve assemblies. Then remove the operating plunger for breaker points, the fuel pump and the tappets. After removing the governor cup assembly from the gear, the camshaft may be pressed out of the gear by using a hollow tool or pipe which will fit over the camshaft center pin. Do not press on the center pin or damage it in any way. The governor ball spacer is a press fit to the camshaft gear.

4. Pistons and Rings:

The piston and connecting rod assemblies are removed from the top of the cylinder. The pistons are fitted with two compression rings and one oil control ring with an expander.

Inspect each piston. The piston ring grooves should be cleaned of any carbon deposits and the oil return slots in the lower groove must be open.

5. Bearings:

Removal of the camshaft or camshaft bearings requires complete disassembly of the engine. Use a press or a suitable drive plug to remove the bearings. Support the casting to avoid distortion and avoid damaging the bearing bore during removal and installation. Use oil on the bearings to reduce friction when installing and again lubricate with oil after installing.

6. Oil Seal:

The bearing plate must be removed to replace the oil seal. Drive the oil seal out from the inside.

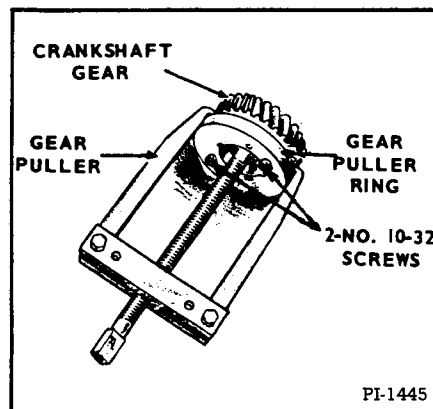
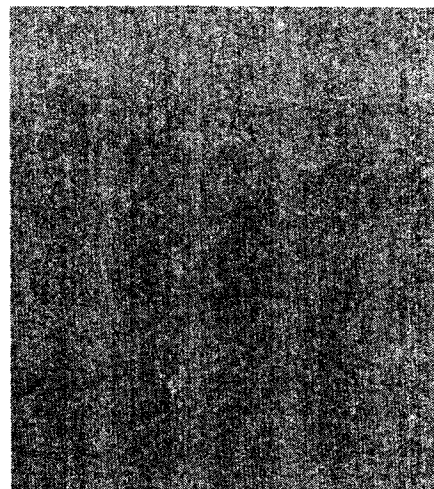
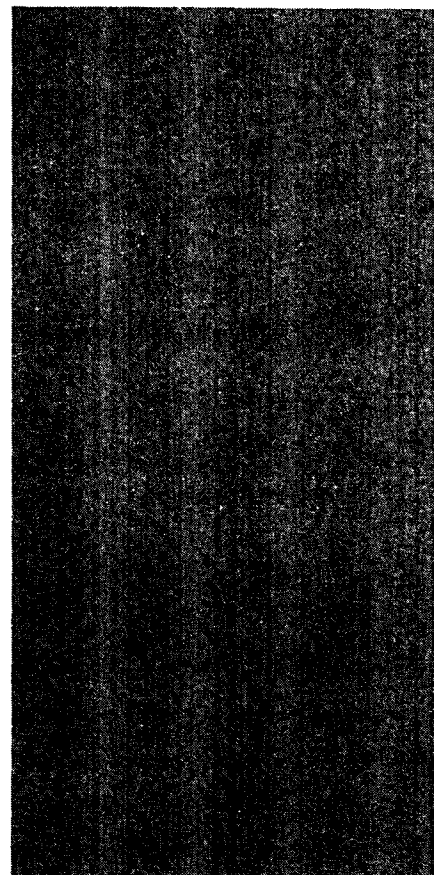

Fig. 276 Pulling Crankshaft Gear



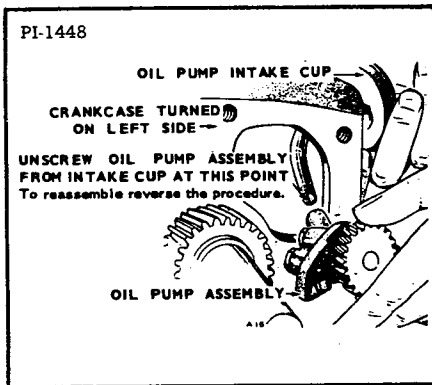

Fig. 277 Removing the Oil Pump

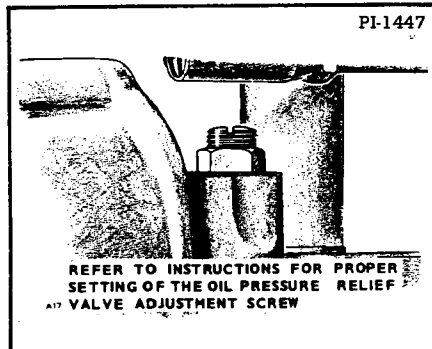

Fig. 278 Adjusting Oil Pressure

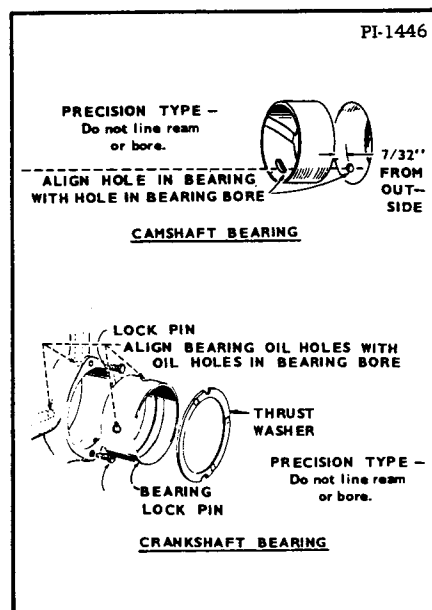
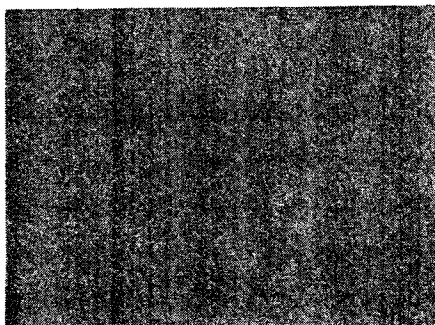

Fig. 279 Bearing Installation



7. Oil Pump:

To remove the oil pump, it is necessary to detach the intake cup assembly (Figure 277).

8. Cylinder:

The cylinder wears very little in normal service. If, through improper lubrication or accident, the cylinder wall should become scored or badly worn, the cylinder may be rebored and honed to accommodate a new piston and rings of one of the available oversizes. Pistons are available in .010", .020", .030", and .040" oversize. Piston rings are available in .010", .020", .030" and .040" oversize.

Use standard rings in a .005" oversize piston. If the cylinder is not being reconditioned, but new piston rings are being installed, remove any ridge which may have formed at the top of the piston ring travel in the cylinder bore. An engine might be fitted with a .005" oversize piston and is so indicated by a letter E following the engine serial number. The serial number is stamped on the cylinder block and on the engine nameplate. The standard cylinder bore size appears in the Table of Clearances. (See page 138).

To reassemble the engine:

1. Oil Pump:

Check the oil pump thoroughly for worn parts. Oil the pump to prime it before reinstalling. Except for gaskets and the suction cup, the component parts of the pump are not available individually. Install a new pump assembly if required (Figure 277).

Engine oil pressure is easily adjusted by means of the slotted stud and locknut located near the breather tube (Figure 278). Oil pressure readings when the engine is warmed up should be between 20 and 35 PSI. To increase oil pressure, loosen the locknut and turn the stud inward. To decrease oil pressure, loosen the locknut and turn the stud outward. Be sure to tighten the locknut securely after making an adjustment. The spring and plunger can easily be removed and cleaned.

2. Bearings:

New crankshaft main bearings are precision type which do not require line reaming or line boring after installation. They are available in standard size, .002", .010", .020" or .030" undersize. Expand the bearing bore by placing the casting in hot water or in an oven heated to 200° F.

WARNING

If a torch is used, apply only a little heat.

If practical, cool the precision bearing to shrink it. Align the oil hole (s) in the bearing with the oil hole (s) in the bearing bore. The oil passage must be at least 1/2 open. The cold oiled precision bearing should require only light taps to position it (Figure 279). Install the bronze faced bearing flush with the inside end of the bore.

If the head of a lock pin is damaged, remove it and install a new pin. Apply oil to the thrust washer to hold it in place while installing the crankshaft. Oil

grooves in the thrust washers must face the crankshaft. The washers must be flat (not bent) and the two notches must fit over the two lock pins to prevent riding on the crankshaft. New camshaft bearings are precision type which do not require line reaming or line boring after installation. Coat the bearing with lubricating oil to reduce friction. Place the bearing on the crankcase over the bearing bore with the elongated hole in proper position and the narrow section facing out (except, in bores without oil holes, install with bearing groove at the top). Be sure to start the bearing straight. Press the rear bearing in flush with the bottom of the counterbore which receives the expansion plug.

3. Oil Seals:

Before installing the seals, fill the space between the lips with a fibrous grease or stiff cup grease. This will improve sealing (Figure 280).

When installing the gear cover oil seal, tap the seal inward until it is $31/32$ " from the mounting face of the cover.

NOTE: Install a new style, thin, open face seal $1-7/64$ " from the mounting face of the cover.

When installing the bearing plate oil seal, tap the seal into the bearing plate bore to bottom against the shoulder in the plate bore. Use a seal expander or place a piece of shim stock around the end of the crankshaft when replacing the bearing plate to avoid damaging the seal. Remove the shim stock as soon as the plate is in place.

4. Crankshaft:

Inspect the bearing journals. If they are scored and cannot be smoothed out by dressing down, the bearing journals should be refinished to use the nearest available undersize bearings or a new crankshaft should be installed. If a worn main bearing journal cannot be fitted with an available precision type undersize bearing, then refinish it to the next undersize.

If a worn rod journal cannot be fitted by installing a new bearing insert, refinish it to take the corresponding undersize rod or bearing insert available.

Inspect the drilled passages of the crankshaft. Clean them to remove any foreign material and to assure proper lubrication of the connecting rods.

After the crankshaft is installed, measure end play (Figure 281).

5. If the pistons are badly scored, very loose in the cylinder, have badly worn ring grooves, or otherwise are not in good condition, install new pistons. Install new pistons if they are so loose on the piston pins that a $.002$ " oversize pin will not correct it. Handle the pistons carefully to avoid nicking the walls. Any raised surface of this type must be dressed down carefully.

Inspect the rings carefully for fit in the grooves, for tension and for seating on the cylinder walls. If in doubt, install new rings.

Before installing new rings, check the ring gap by placing each ring squarely in its cylinder at a position corresponding with the bottom of its travel (Figure 282). The gap between the ends of the ring should be as given in the Table of Clearances, See page 138.

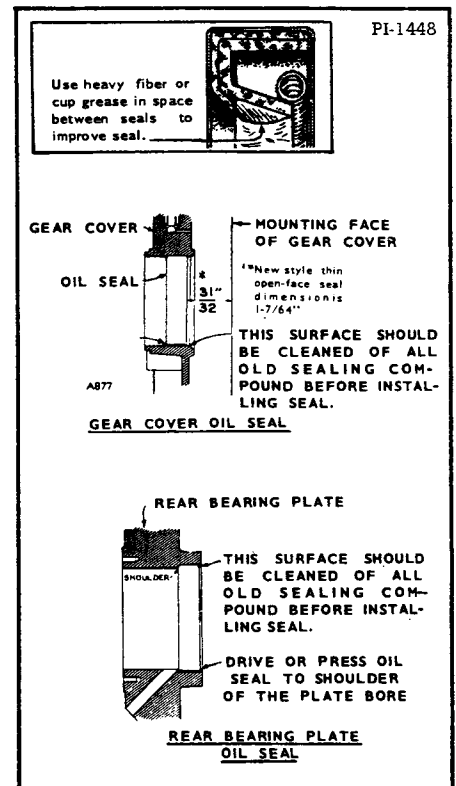

Fig. 280 Installing Oil Seals

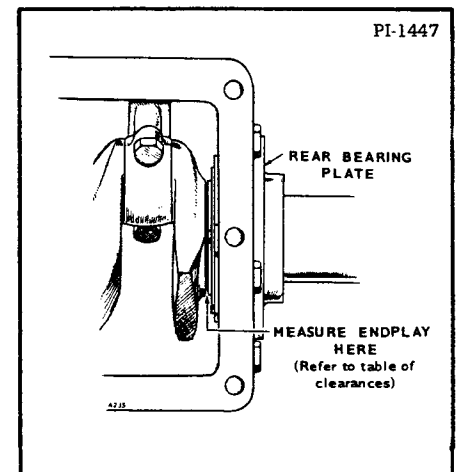

Fig. 281 Crankshaft End Play

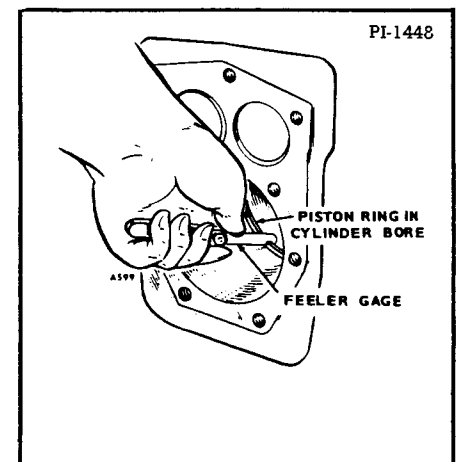

Fig. 282 Ring End Clearance

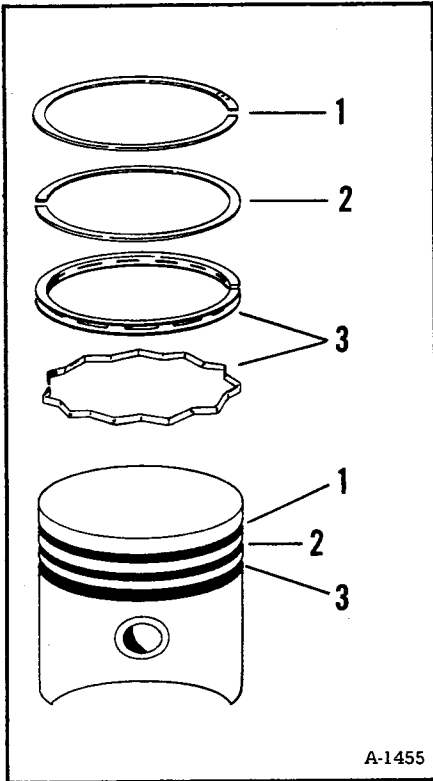

Fig. 283 Installing Rings

Slightly oversize rings may be filled as necessary to obtain the correct gap, but do not use rings which require too much filing. Standard size rings may be used on .005" oversize pistons; .010", .020", .030" and .040" oversize rings are to be used on the corresponding size piston. Tapered rings are usually marked TOP on one side, or identified in some other manner. These rings must be installed with this mark toward the piston head. Space each ring gap one third of the way around the piston from the preceding one, with no gap directly in line with the piston pin. The bottom piston ring groove should be fitted with an expander and an oil control ring and the two upper rings fitted with compression rings (Figure 283).

The piston is fitted with a full floating piston pin. The pin is kept in place by two lock rings, one at each side. Be sure these lock rings are properly positioned in their groove before installing the piston and connecting rod into the engine. Correct piston to cylinder clearance appears in the Table of Clearance.

6. Connecting Rods:

The connecting rods should be serviced at the same time the pistons or piston rings are serviced. Rod bearing inserts are available in .002", .010" or .030" undersize.

For clearances, refer to the Table of Clearances.

The connecting rod and piston assembly must be properly aligned before reassembly to the engine. The aligning should be done on an accurate aligning gauge by a competent operator. Misalignment may cause rapid wear of the piston, pin, cylinder and connecting rod.

Install the connecting rods and caps with the raised lines (witness marks) aligned, and with the caps facing toward the oil base. The rod and cap numbered two fits on the crankshaft journal nearer the bearing plate. Coat the crankshaft journal bearing surfaces with oil before installing the rods. Crank the engine by hand to see that the rods are free. If necessary, rap the connecting rod cap screws sharply with a soft faced hammer to set the rod square on the journal.

7. Timing Gears:

When pressing a gear onto the camshaft, be sure it is started straight and the key is properly in place. Install the governor cup assembly before installing the camshaft and gear.

Each timing gear is stamped with an "O" near the edge (Figure 284). The gear teeth must meet so these marks exactly coincide when the gears are installed in the engine. When installing the camshaft gear and shaft assembly, be sure the thrust washer is properly in place behind the camshaft gear. Then install the crankshaft retaining washer and lock ring.

8. Governor Cup:

Replace, with a new part, any flyball which is grooved or has a flat spot; the ball spacer if its arms are worn or otherwise damaged; and the governor cup if the race surface is grooved or rough. The governor cup must be a free spinning fit on the camshaft center pin, but without any excessive play.

When installing the governor cup, tilt the engine so the gear is up, put the flyballs into place (equally spaced) and install the cup and snap ring on the center pin.

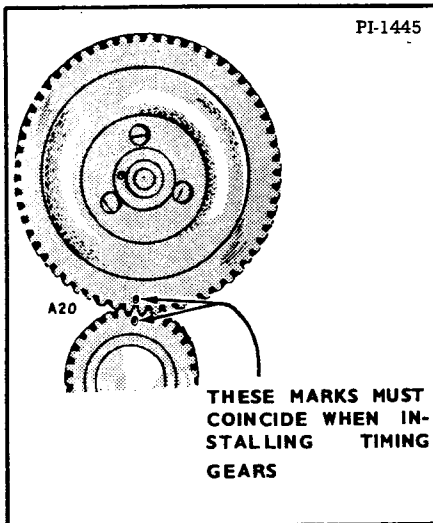
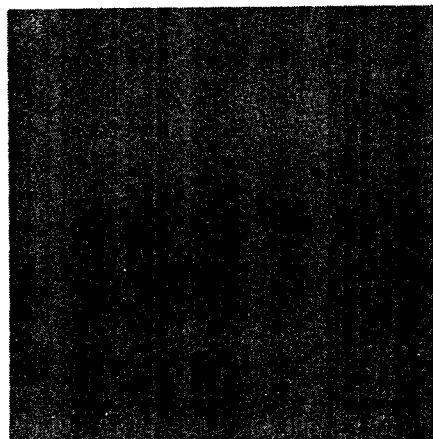

Fig. 284 Timing Gears



The camshaft center pin extends out 3/4" from the end of the camshaft. This distance provides an in and out travel distance of 7/32" for the governor cup (Figure 285). Hold the cup against the flyballs when measuring.

If the distance is less (the engine will race, especially at no load) remove the center pin and press in a new pin or grind off the hub of the cup as required. The camshaft center pin cannot be pulled outward or removed without damage. If the center pin extends out too far, the cup will not hold the flyballs properly.

9. Gear Cover:

When installing the gear cover, make sure the pin in the gear cover engages the metal lined (smooth) hole in the governor cup. Turn the governor cup so the metal lined hole is at the three o'clock position. The smooth side of the governor yoke must ride against the governor cup. Turn the governor arm and shaft clockwise as far as possible and hold in their position until the gear cover is installed flush against the crankcase. Be careful not to damage the gear cover oil seal. Adjust the roll (stop) pin to protrude to a point 3/4" from the cover mounting surface (Figure 286).

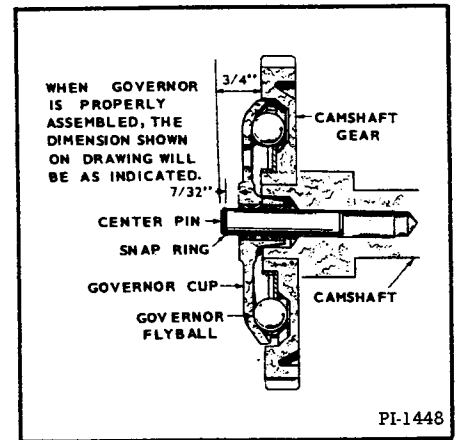

Fig. 285 Installing Governor

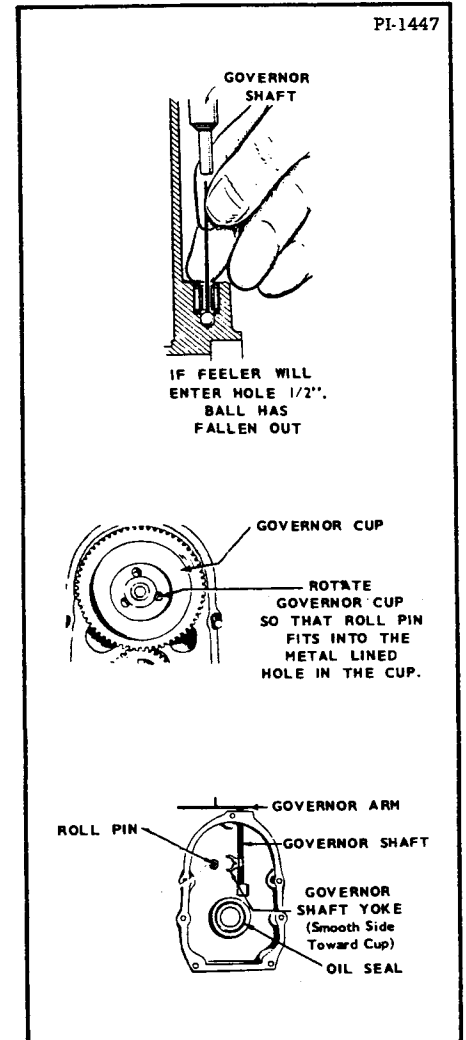
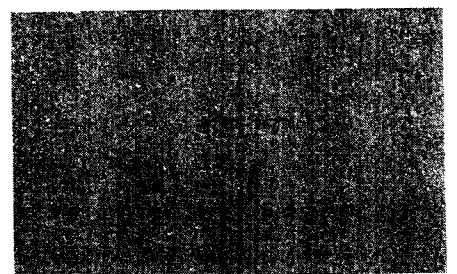

Fig. 286 Installing Gear Cover



TECHNICAL DATA (Onan)

FITS & CLEARANCES

(All Clearances Given at Room Temperature of 70° F.)

Tappets	0.010" - 0.012"
Valve Stem in Guide - Intake	0.001" - 0.0025"
Valve Stem in Guide - Exhaust	.0025" - 0.004"
Valve Seat Interference Width	.1/32" - 3/64"
Valve Face Angle	44°
Valve Seat Angle	45°
Valve Interference Angle	.1°
Crankshaft Main Bearing	

Aluminum Alloy, Flanged - Prior Spec F	0.002" - 0.003"
Bronze Faced - Begin model Spec F	0.0025" - 0.0035"

Crankshaft End Play	0.006" - 0.012"
Camshaft Bearing	0.0015" - 0.003"
Camshaft End Play	0.003"
Rod Bearing	0.0005" - 0.002"
Connecting Rod End Play	0.002" - 0.016"
Timing Gear Backlash	0.002" - 0.003"
Oil Pump Gear Backlash	0.002" - 0.005"
Piston to Cylinder, Conformatric Type (Measured at Bottom of Skirt)	

Interference	0.0005"
Clearance	0.0015"

Piston Pin in Piston	Thumb Push Fit
Piston Pin in Rod	0.0001" - 0.0006"
Piston Ring Gap in Cylinder	0.010" - 0.023"
Breaker Point Gap (Full Separation)	0.020"
Spark Plug Gap - For Gaseous Fuel	0.018"
Spark Plug Gap - For Gasoline Fuel	0.025"
Crankshaft Main Bearing Journal - Std. Size	1.9995" - 2.000"
Crankshaft Rod Bearing Journal - Std. Size	1.6255" - 1.6260"
Cylinder Bore - Std. Size	3.249" - 3.250"
Ignition Timing Advance	

1,500 to 2,400-rpm (without Automatic Spark Advance)	19° BTC
2,500 and up (without Automatic Spark Advance)	25° BTC
Stopped (with Automatic Spark Advance)	5° BTC
Running (with Automatic Spark Advance)	24° BTC

TORQUE VALUES

Cylinder Head Cap Screws	29 - 31 ft. lbs.
Rear Bearing Plate Nuts	20 - 25 ft. lbs.
Connecting Rod Screw - Aluminum Rod	24 - 26 ft. lbs.
Connecting Rod Bolt - Forged Steel Rod	27 - 29 ft. lbs.
Flywheel Cap Screw	35 - 40 ft. lbs.
Other 5/16" Cylinder Block Studs and Nuts	10 - 12 ft. lbs.

TROUBLESHOOTING GASOLINE & LP ENGINES

PROBLEM	CAUSE	CORRECTION	PAGE
Engine will not turn over with starter.	Blown fuse in the wiring harness.	Replace the fuse.	
	Loose battery connections.	Clean the battery terminals and reattach the cables, tightening them securely.	
	Battery is discharged.	Re-charge the battery. Check the function of the charging system.	
	Defective starter switch.	Replace the switch.	
	Loose starter connections.	Tighten the connections securely.	
	Broken or disconnected wiring harness.	Reconnect or replace the wiring harness.	
Engine fails to start or is difficult to start.	The variable speed is in high speed position.	Pull the variable speed drive control lever all the way back before stopping the engine.	
	The clutches are partially engaged with the steering levers in neutral position. The loader will tend to rock or move while starting.	Adjust the clutches so the levers will travel 3 to 4 inches from neutral position, in each direction.	
	Improper starting procedure.	Refer to "Starting Procedure" in the Bobcat Operation section of this manual.	
	No fuel in the tank.	Refuel.	
	The engine air cleaner is dirty.	Service the air cleaner.	
	The air vent hole in the fuel tank cap is plugged.	Remove and clean the cap.	
	Leaky fuel line.	Correct as required.	
	Damaged fuel pump.	Readjust, repair or replace.	
	The carburetor is not being choked sufficiently, especially if the engine is cold.	Choke as required. If the cylinders start to flood, push the throttle control all the way forward. Start the engine.	
	The carburetor is being choked too much when starting a warm engine.	You should not normally need to choke an engine that is warm.	
	The cylinders are flooded.	Crank the engine a few times with the spark plugs removed. Be careful when doing this. Clean & dry the spark plugs.	
	Water, dirt or gum in the gasoline is interfering with fuel flow.	Drain & clean the fuel system. Refill with clean fuel.	
	Dirty carburetor.	Correct as required.	
	The ignition cable is disconnected from the magneto, distributor or spark plugs.	Reconnect the ignition cable.	
	Broken ignition cables, causing short circuits.	Replace broken ignition cables.	
	The ignition cables, distributor or spark plugs are wet.	Dry and clean them.	
	Moisture in the ignition system due to fertilizer dust settling into or around switches, fuses, ignition wire, battery terminals or distributor cap. The fertilizer dust draws moisture.	Store the idle machine in a dry place as far as possible from stored fertilizer.	
		Blow fertilizer dust off the machine daily and wash it off frequently with diesel fuel.	
Spray the ignition system with a sealant made to prevent moisture problems.			

PROBLEM	CAUSE	CORRECTION	PAGE
	The spark plugs are wet, dirty, fouled or	Clean or replace the spark plugs.	
	The spark plug gaps are wrong.	Re-gap or replace the plugs.	
	The ignition is out of time.	Retime.	
	Faulty condenser or coil.	Replace.	
	Faulty magneto or distributor.	Repair or replace.	
	The crankcase oil is too heavy (cold weather).	Use an engine oil fo the proper viscosity.	
	The valves are leaking or sticking.	Clean and reseal the valves.	
	Incorrect valve tappet adjustment.	Adjust.	
	Cylinders dry due to engine having been out of use for some time (poor compression).	Restore compression by pouring a small amount of engine oil into the cylinders.	
	Loose spark plugs.	Install new gaskets & retorque plugs.	
	Damaged cylinder head gasket or loose cylinder head.	Install new gasket & retorque head.	
	Piston rings stuck in piston.	Remove & clean the parts.	
	Scored cylinders (lack of compression).	Correct as required.	
Engine Misses.	Spark plug gap incorrect.	Reset the spark plug gaps.	
	Wrong type spark plugs.	Check against recommendations.	
	Improper ignition timing.	Retime the engine.	
	Fouled spark plugs.	Clean or replace. Check cause of fouling.	
	Pitted breaker points.	Check for cause.	
	Loose ignition cables or worn or broken cables.	Correct as required.	
	Water in gasoline.	Drain & refill.	
	Poor compression.	Tighten cylinder heads and spark plugs.	
	Incorrect fuel mixture.	Readjust carburetor.	
	Dirty carburetor.	Clean.	
Clogged fuel screen.	Clean.		
Engine Surges or Gallops.	Carburetor flooding.	Check carburetor adjustment.	
	Governor incorrectly adjusted.	Readjust.	
Backfiring	Lean fuel mixture.	Readjust carburetor.	
	Improper ignition timing.	Retime.	
	Improper breaker point gap.	Readjust.	
	Sticky intake valve.	Correct as required.	
Engine Overheats.	Engine is overloaded.	Operate at a lower variable speed setting.	
		Operate at a 3/4 to full throttle setting.	
	Engine cooling fins are dirty.	Clean the cooling fins thoroughly.	
	Engine has been operated with part of the shrouding removed.	Clean the cooling fins and replace the shrouding.	
Dirty engine oil.	Change engine oil.		