

## HYDRAULIC SYSTEM

	Page Number
BUCKET POSITION VALVE (S/N 15001 & Above)	
Disassembly and Assembly . . . . .	2-49
Removal and Installation . . . . .	2-49
HYDRAULIC CONTROL PEDALS (S/N 14999 & Below)	
Adjustment . . . . .	2-60
Removal and Installation . . . . .	2-60
HYDRAULIC CONTROL PEDALS (S/N 15001 & Above)	
Adjustment . . . . .	2-61
Removal and Installation . . . . .	2-61
HYDRAULIC CONTROL VALVE (CESSNA)	
Assembly . . . . .	2-29
Auxiliary Section . . . . .	2-27
Checking the Main Relief Valve . . . . .	2-18
Disassembly . . . . .	2-21
Inlet Section . . . . .	2-22
Lift Section . . . . .	2-25
Main Relief Valve Removal and Installation . . . . .	2-19
Removal and Installation . . . . .	2-19
Tilt Section . . . . .	2-23
Valve Spool Bolt . . . . .	2-28
HYDRAULIC CONTROL VALVE (MELROE)	
Centering Mechanism . . . . .	2-38
Checking the Main Relief Valve . . . . .	2-30
Detent Assembly . . . . .	2-35
Disassembly and Assembly . . . . .	2-33
Removal and Installation . . . . .	2-31
HYDRAULIC CYLINDER REPAIR	
Assembly . . . . .	2-15
Disassembly . . . . .	2-13
HYDRAULIC FLUID FILTER HOUSING (S/N 15001 & Above)	
By-Pass Valve . . . . .	2-57
Removal and Installation . . . . .	2-57
HYDRAULIC/HYDROSTATIC RESERVOIR (S/N 21514 & Below)	
Removal and Installation . . . . .	2-58
HYDRAULIC PUMP (DOUBLE STAGE)	
Checking the Output of the Hydraulic Pump . . . . .	2-43
Disassembly and Assembly . . . . .	2-46
Inspection . . . . .	2-48
Removal and Installation . . . . .	2-44
HYDRAULIC PUMP (SINGLE STAGE)	
Checking the Output of the Hydraulic Pump . . . . .	2-39
Disassembly and Assembly . . . . .	2-40
Inspection . . . . .	2-42
Removal and Installation . . . . .	2-40

Continued on Next Page

**HYDRAULIC  
SYSTEM**

## HYDRAULIC SYSTEM (Cont'd)

	Page Number
HYDRAULIC SYSTEM INFORMATION	
Flare Connections . . . . .	2-2
Straight Thread O-Ring Fitting . . . . .	2-2
Tubelines and Hoses . . . . .	2-2
LIFT CYLINDERS	
Checking the Lift Cylinder(s) . . . . .	2-3
Removal and Installation . . . . .	2-3
PEDAL LOCK LINKAGE	
Adjustment . . . . .	2-62
PORT BLOCK (S/N 14999 & Below)	
40 Micron Filter (Bronze) . . . . .	2-51
Neutral By-Pass Valve . . . . .	2-52
Removal and Installation . . . . .	2-52
PORT BLOCK (S/N 15001 & Above)	
Charge By-Pass . . . . .	2-56
Cold Oil By-Pass . . . . .	2-56
Removal and Installation . . . . .	2-55
TILT CYLINDER	
Checking the Tilt Cylinder . . . . .	2-5
Removal and Installation . . . . .	2-5
Rod End Seal . . . . .	2-6
TILT CYLINDER (CESSNA)	
Assembly . . . . .	2-9
Disassembly . . . . .	2-7
TROUBLESHOOTING	
Chart . . . . .	2-1

# HYDRAULIC / HYDROSTATIC FLOW CHART

For Model

843 (S/N 11001 Thru 12999)

Chart #6566716 (Printed November 1988)



- RED - High Pressure
- BLUE - Low Pressure
- GREEN - Case Drain & Reservoir
- ORANGE - Charge Pressure

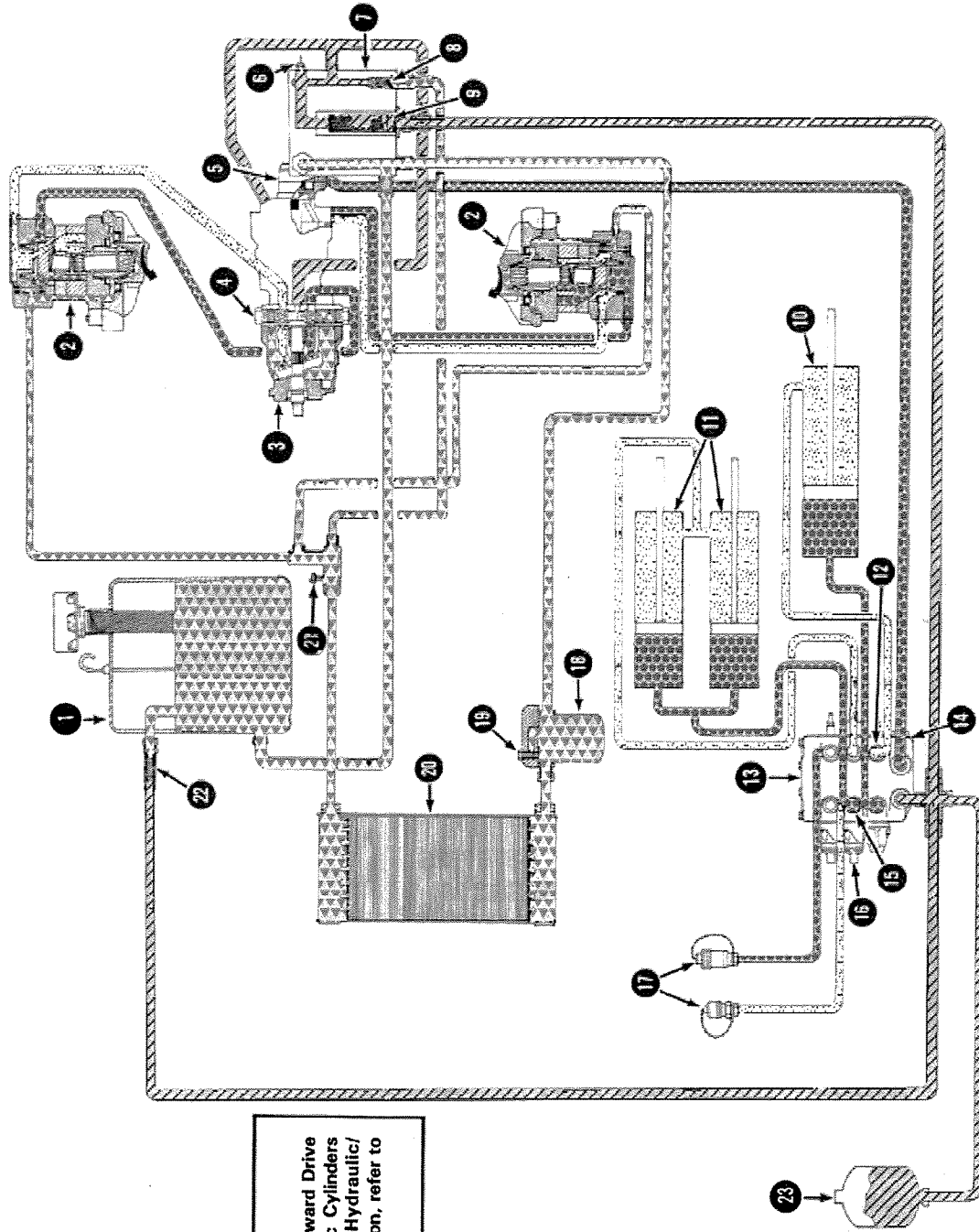

**NOTE**  
 Chart shows oil flow in Forward Drive Position and with Hydraulic Cylinders Partially Extended. For Hydraulic/Hydrostatic System Operation, refer to Sheet 2 of this publication.



# HYDRAULIC / HYDROSTATIC SYSTEM OPERATION

To Be Used With  
**HYDRAULIC / HYDROSTATIC FLOW CHART**

For Model  
**843 (S/N 11001 Thru 12999)**  
Chart # 6566716 (Printed November 1988)

## CHART LEGEND

- ① **FLUID RESERVOIR,**  
Cap.: . . . . . 6.0 Gals. (22,7 L)  
Working Cap.: . . . . . 3.5-4.0 Gal.  
(13,2-15,1 L)
- ② **HYDROSTATIC MOTOR, . . . 15 cu. in.**  
(246 cm<sup>3</sup>)
- ③ **HYDROSTATIC PUMP**
- ④ **HIGH PRESSURE RELIEF REPLENISHING VALVES, . . . 3500 PSI (24132 kPa)**
- ⑤ **HYDRAULIC PUMP, . . . . . 15.4 GPM**  
(58,3 Lmin.) at 2720 RPM
- ⑥ **TEMPERATURE SWITCH, . . . 210°F.**  
(99°C)
- ⑦ **PORT BLOCK**
- ⑧ **RELIEF VALVE, . . . . . 43-57 PSI**  
(296-393 kPa)
- ⑨ **FILTER . . . . . 40 Micron**
- ⑩ **TILT CYLINDER (Cushioned)**
- ⑪ **LIFT CYLINDERS**
- ⑫ **ORIFICE, . . . . . 0.099" (2,51 mm) Dia.**  
SN 11935 & Below  
**ORIFICE, . . . . . 0.138" (3,51 mm) Dia.**  
Starting With SN 11936
- ⑬ **HYDRAULIC CONTROL VALVE,**  
Self-Level
- ⑭ **MAIN RELIEF, . . . . . 2325-2500 PSI**  
(16030-17237 kPa) (Measured at Quick Couplers)
- ⑮ **RESTRICTOR (In Float and Lower Position Only)**
- ⑯ **PORT RELIEF (Lift Section)**  
3500 PSI (24132 kPa)
- ⑰ **AUXILIARY QUICK COUPLERS**
- ⑱ **FILTER, . . . . . 10 Micron**
- ⑲ **FILTER BY-PASS, . . . 30 PSI (207 kPa)**
- ⑳ **OIL COOLER**
- ㉑ **PRESSURE SWITCH, . . . . . 2.5-3.5 PSI**  
(17,3-24,1 kPa)
- ㉒ **BY-PASS VALVE, . . . . . 180-200 PSI**  
(1241-1379 kPa)
- ㉓ **ACCUMULATOR, Nitrogen Precharge**  
120 PSI (827 kPa) (Starting at  
S/N 11936)



## OIL FLOW EXPLANATION

The fluid flows from the reservoir ① to the inlet of the port block ⑦. Reservoir fluid is joined by the hydrostatic motor ② case drain and the return fluid from the oil cooler ⑳. This combined flow supplies fluid to the hydraulic pump ⑤.

The hydraulic pump ⑤ (a "gear" type) forces the fluid to the hydraulic control valve ⑬. When all three spools are in neutral position, the fluid goes through the control valve ⑬ and either to the reservoir ① or to the port block ⑦. The hydraulic control valve ⑬ is a three section, parallel open center, closed port valve with a main relief valve ⑭ built into the inlet section of the control valve ⑬.

When one of the spools is activated, the fluid flow is directed to either the base end or the rod end of the cylinder(s) ⑩ ⑪. Return fluid from the other end of the cylinder(s) ⑩ ⑪ goes back to the hydraulic control valve ⑬ and goes to the 40 micron filter ⑨ in the port block ⑦. The "tee" fitting at the outlet of the control valve ⑬ allows fluid to return to either the by-pass valve ⑳ and to the fluid reservoir ① through a diffuser or to the 40 micron filter ⑨ in the port block ⑦ during normal operation. \*The "tee" fitting also connects to an accumulator ㉓ which will provide a temporary charge pressure flow when the lift and tilt cylinders are being extended. Two sections on the control valve ⑬ can be used at the same time if the main relief valve ⑭ is not open.

\*The accumulator ㉓ is standard beginning with serial number 11936.

The by-pass valve ㉒ will open during cold weather or if there is excessive fluid pressure. The normal fluid flow through the 40 micron filter ⑨, goes by the temperature switch ⑥, and against the neutral charge by-pass valve ⑧. The normal flow is through the "tee" fitting between the temperature switch ⑥ and the charge by-pass valve ⑧ to the front and the rear hydrostatic pumps ③. The fluid flow is called "charge pressure" and supplies the hydrostatic pumps ③ and the hydrostatic motors ② with charge fluid. The charge fluid is used by the pump and motor, but as the charge pressure increases, the charge by-pass valve ⑧ will open to prevent excessive pressure built up.

The neutral charge fluid flows into each hydrostatic pump ③ and hydrostatic motor ② to cool, lubricate and replenish the fluid supply which is lost through case drain. Hydrostatic pumps ③ case drain flows into the inlet side of the hydraulic pump ⑤ through internal porting.

There are two hydrostatic pumps ③ and two hydrostatic motors ②. One pump and one motor work together as a pair to drive on one side of the loader. The other pump and motor work as a pair to drive the opposite side of the loader.

When the hydrostatic pumps ③, swashplate are angled in either direction, the hydrostatic

pumps ③ force fluid, under high pressure, to the hydrostatic motors ② . The hydrostatic motors ② turn and push the low pressure fluid back to the hydrostatic pumps ③ to be used again. The hydrostatic motors ② also contain a shuttle valve to allow some of the fluid from the "drive loop" to go to the oil cooler ⑳ for cooling. The hydrostatic pumps ③ center section contains four high pressure relief/replenishing valves ④ . Two for each side, one for forward travel and one for reverse travel. The high pressure replenishing valves ④ have a dual function. In neutral the valve cartridges ④ are pushed off their seats to allow fluid flow from the charge loop to the cool, lubricate and replenish the pumps and the motors. When the swashplates are angled, the fluid is at a higher pressure than the charge fluid, this pressure difference causes the high pressure replenishing valves ④ to be forced against the seats. The high pressure replenishing valves ④ also act as a high pressure relief valve for the hydrostatic pumps ③ , in case of excessive pressure being generated by the hydrostatic pumps ③ . The high pressure replenishing valves ④ will open allowing the "drive pressure" to relieve into the charge loop to be used again.

Excess charge pressure fluid which is relieved over the charge by-pass valve ⑧ is routed to the "tee" and joins the hydrostatic motor ② case drain fluid and flows to the oil cooler ⑳ . The "tee" fitting has a pressure switch ㉑ that senses a drop in pressure of the fluid which goes to the oil cooler ⑳ . Fluid from the oil cooler ⑳ flows through the filter ⑱ which has a built in by-pass valve ⑲ . The fluid then flows into the inlet of the port block and back to the hydraulic pump ⑤ .



# HYDRAULIC / HYDROSTATIC FLOW CHART

For Model

843 (S/N 13001 Thru 14999)

(With Accumulator and Charge Line Filter)

Chart #6566748 (Printed November 1988)



**bobcat**

- RED - High Pressure
- BLUE - Low Pressure
- GREEN - Case Drain & Reservoir
- ORANGE - Charge Pressure

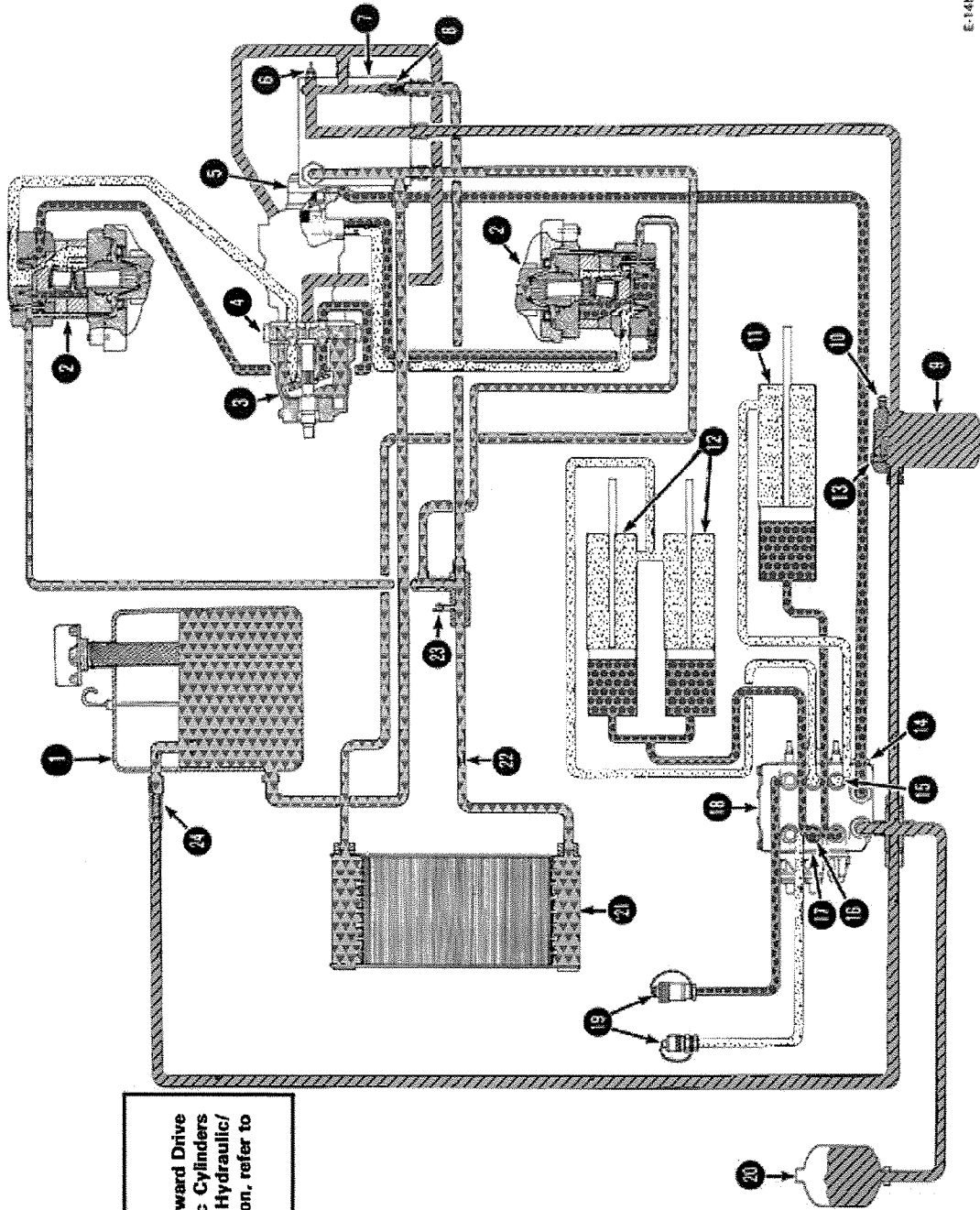

**NOTE**  
 Chart shows oil flow in Forward Drive Position and with Hydraulic Cylinders Partially Extended. For Hydraulic/Hydrostatic System Operation, refer to Sheet 2 of this publication.

6566748 (11-88)

(Sheet 1 of 2)

Printed in U.S.A.

E-1485  
 E-1475



# HYDRAULIC / HYDROSTATIC SYSTEM OPERATION

To Be Used With  
**HYDRAULIC / HYDROSTATIC FLOW CHART**

For Model  
**843 (S/N 13001 Thru 14999)**  
**(With Accumulator and Charge Line Filter)**

Chart # 6566748 (Printed November 1988)

## CHART LEGEND

- ① **FLUID RESERVOIR,**  
Cap.: . . . . . 6.0 Gals. (22,7 L)  
Working Cap.: . . . . . 3.5-4.0 Gal.  
(13,2-15,1 L)
- ② **HYDROSTATIC MOTOR, . . . . .** 15 cu. in.  
(246 cm<sup>3</sup>)
- ③ **HYDROSTATIC PUMP**
- ④ **HIGH PRESSURE RELIEF REPLENISHING VALVES, . . . . .** 3500 PSI (24132 kPa)
- ⑤ **HYDRAULIC PUMP, . . . . .** 15.4 GPM  
(58,3 Lmin.) at 2720 RPM
- ⑥ **TEMPERATURE SWITCH, . . . . .** 225-232°F.  
(108-130°C)
- ⑦ **PORT BLOCK**
- ⑧ **RELIEF VALVE, . . . . .** 43-57 PSI  
(296-393 kPa)
- ⑨ **FILTER . . . . .** # 3
- ⑩ **DIFFERENTIAL PRESSURE SWITCH, . . . . .**  
19 PSI (131 kPa)
- ⑪ **TILT CYLINDER (Cushioned)**
- ⑫ **LIFT CYLINDERS**
- ⑬ **FILTER BY-PASS, . . . . .** 25 PSI (172 kPa)
- ⑭ **MAIN RELIEF, . . . . .** 2125-2225 PSI  
(14651-15341 kPa)
- ⑮ **ORIFICE, . . . . .** 0.099" (2,51 mm) Dia.
- ⑯ **RESTRICTOR (In Float and Lower Position Only)**
- ⑰ **PORT RELIEF (Lift Section)**  
3500 PSI (24132 kPa)
- ⑱ **HYDRAULIC CONTROL VALVE, Self Level**
- ⑲ **AUXILIARY QUICK COUPLERS**
- ⑳ **ACCUMULATOR**
- ㉑ **OIL COOLER**
- ㉒ **ORIFICE RESTRICTOR, . . . . .** 0.275" (6.99 mm) Dia.
- ㉓ **PRESSURE SWITCH, . . . . .** 2.5-3.5 PSI (17,3-24,1 kPa)
- ㉔ **BY-PASS VALVE, . . . . .** 180-200 PSI (1241-1379 kPa)

## OIL FLOW EXPLANATION

The fluid flows from the reservoir ① to the inlet of the port block ⑦ . Reservoir fluid is joined by the hydrostatic motor ② case drain and the return fluid from the oil cooler ② . This combined flow supplies fluid to the hydraulic pump ⑤ .

The hydraulic pump ⑤ (a "gear" type) forces the fluid to the hydraulic control valve ⑩ . When all three spools are in neutral position, the fluid goes through the control valve ⑩ and either to the reservoir ① or to the port block ⑦ . The hydraulic control valve ⑩ is a three section, parallel open center, closed port valve with a main relief valve ⑭ built into the inlet section.

When one of the spools is activated, the fluid flow is directed to either the base end or the rod end of the cylinder(s) ⑪ ⑫ . Return fluid from the other end of the cylinder(s) ⑪ ⑫ goes back to the hydraulic control valve ⑩ and through the 3 micron filter ⑨ and back to the port block ⑦ . The "tee" fitting at the outlet of the control valve ⑩ allows fluid to return to either the by-pass valve ⑮ and to the fluid reservoir ① through a diffuser or through the #3 filter ⑨ and to the port block ⑦ during normal operation. \*The "tee" fitting also connects to an accumulator ⑳ which will provide a temporary charge pressure flow when the lift and tilt cylinders are both being extended. Two sections on the control valve ⑩ can be used at the same time if the main relief valve ⑭ is not open.

The by-pass valve ⑮ will open during cold weather or if there is excessive fluid pressure. The flow of fluid is through the #3 filter ⑨ , into the port block ⑦ , past the temperature switch ⑥ and against the neutral charge by-pass valve ⑧ . The normal flow is through the "tee" fitting between the temperature switch ⑥ and the charge by-pass valve ⑧ to the front and the rear hydrostatic pumps ③ . This fluid flow is called "charge pressure" and supplies the hydrostatic pumps ③ and the hydrostatic motors ② with charge fluid. The charge fluid is used by the pump and motor, but as the charge pressure increases, the charge by-pass valve ⑧ will open to prevent excessive pressure build up.

The neutral charge fluid flows into each hydrostatic pump ③ and hydrostatic motor ② to cool, lubricate and replenish the fluid supply which is lost through case drain. Case drain from the hydrostatic pumps ③ flows into the inlet side of the hydraulic pump ⑤ through internal porting.

There are two hydrostatic pumps ③ and two hydrostatic motors ② . One pump and one motor work together as a pair to drive one side of the loader. The other pump and motor work as a pair to drive the opposite side of the loader.

When the swashplates, of the hydrostatic pumps ③ , are angled in either direction, the hydrostatic pumps ③ force fluid, under high pressure, to the hydrostatic motors ② . The

hydrostatic motors ② turn and push the low pressure fluid back to the hydrostatic pumps ③ to be used again. The hydrostatic motors ② also contain a shuttle valve to allow some of the fluid from the drive loop to go to the oil cooler ②1 for cooling. The hydrostatic pumps ③ center section contains four high pressure relief/replenishing valves ④ . There are two for each side; one for forward travel and one for reverse travel. The high pressure replenishing valves ④ have a dual function. In neutral the valve cartridges ④ are pushed off their seats to allow fluid flow from the charge loop to the cool, lubricate and replenish the pumps and the motors. When the swashplates are angled, the fluid is at a higher pressure than the charge fluid, this pressure difference causes the high pressure replenishing valves ④ to be forced against the seats. The high pressure replenishing valves ④ also act as a high pressure relief valve for the hydrostatic pumps ③ , in case of excessive pressure being generated by the hydrostatic pumps ③ . The high pressure replenishing valves ④ will open allowing the "drive pressure" to relieve into the charge loop to be used again.

Excess charge pressure fluid which is relieved over the charge by-pass valve ⑧ is routed to the "tee" block and joins the hydrostatic motor ② case drain fluid and flows to the oil cooler ②1 . The "tee" fitting has a pressure switch ②3 that senses a drop in pressure of the fluid which goes to the oil cooler ②1 . Fluid from the oil cooler ②1 flows into the inlet of the port block ⑦ and back to the hydraulic pump ⑤ .





# HYDRAULIC / HYDROSTATIC FLOW CHART

For Model

## 843 (S/N 15001 Thru 25999)

Chart #6570242 (Printed April 1986)

- RED - High Pressure
- BLUE - Low Pressure
- GREEN - Case Drain & Reservoir
- ORANGE - Charge Pressure
- LT. ORANGE - Hydraulic Pump Charge

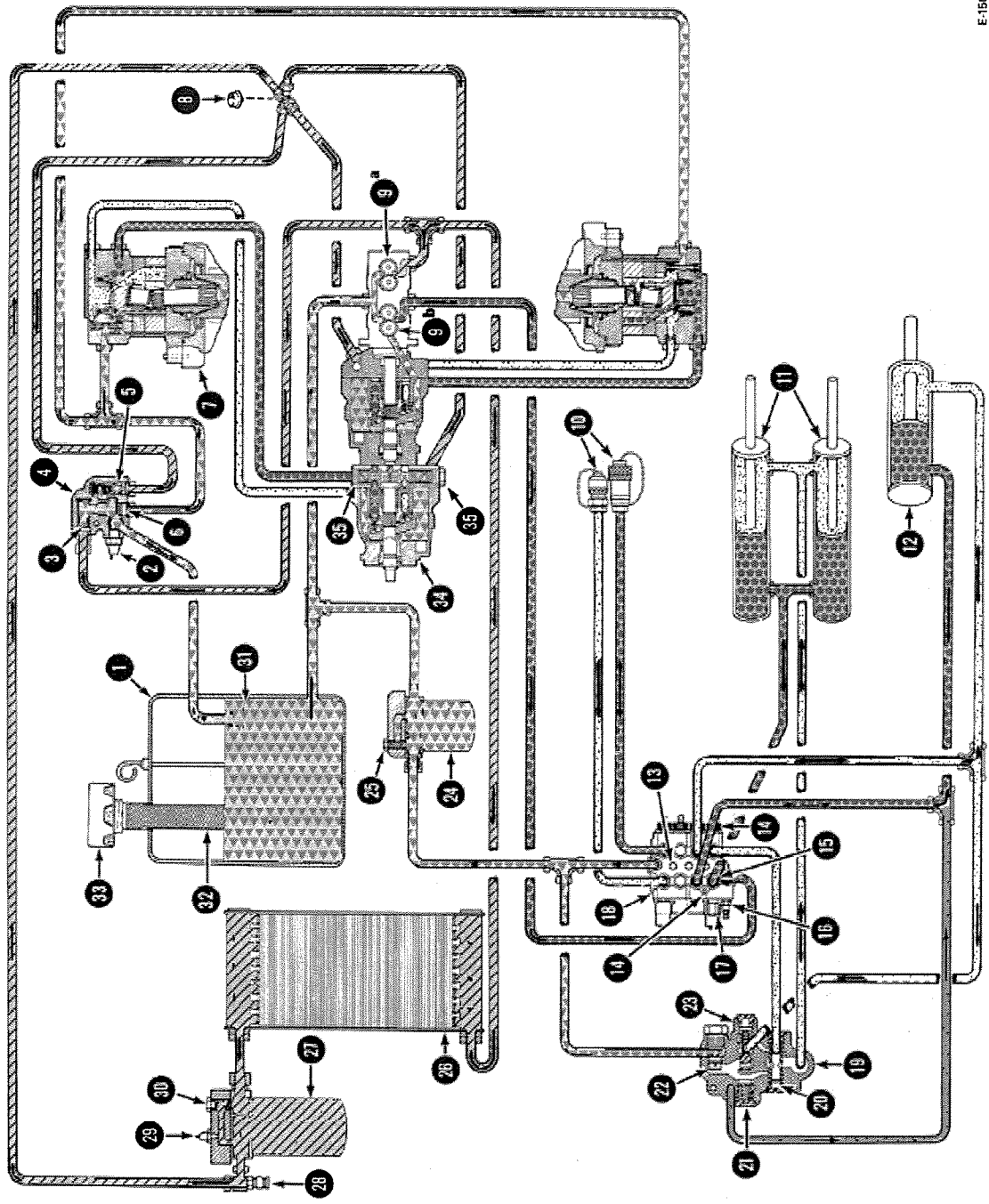



# HYDRAULIC / HYDROSTATIC SYSTEM OPERATION

To Be Used With

## HYDRAULIC / HYDROSTATIC FLOW CHART

For Model

**843 (S/N 15001 Thru 25999)**

Chart # 6570242 (Printed April 1986)

### CHART LEGEND

- 1 RESERVOIR, Cap.: . . . . . 3.5-4.0 Gals.  
(13,2-15,1 L)
- 2 TEMPERATURE SWITCH, . . . 225-232°F  
(108-111°C)
- 3 COLD OIL BY-PASS VALVE, . . . 297 PSI  
(2048 kPa)
- 4 PORT BLOCK
- 5 CHARGE BY-PASS VALVE, . . . 110 PSI  
(758 kPa)
- 6 ORIFICE . . . Motor Case Drain 0.217"  
(5,51 mm) Dia.
- 7 HYDROSTATIC MOTOR
- 8 PRESSURE SWITCH (Dual Function),  
Hourmeter Starts @ 19-23 PSI (132-158  
kPa) Warning Light Turns off @ 17-21 PSI  
(118-144 kPa)
- 9 HYDRAULIC PUMP, Gear Type
  - a. Charge Pump, 11.5 GPM (43,5 L/min.)  
@ 2700 RPM @ 1050 PSI (7239 kPa)
  - b. Hydraulic Pump, 16.1 GPM (60,9 L/min.)  
@ 2700 RPM @ 1050 PSI (7239 kPa)
- 10 HYDRAULIC AUXILIARY LINES
- 11 LIFT CYLINDERS
- 12 TILT CYLINDERS
- 13 LOAD CHECK VALVES (Four)
- 14 ANTI-CAVITATION CHECK VALVE
- 15 ORIFICE
- 16 MAIN RELIEF VALVE, . . . 2250-2400 PSI  
(15514-16548 kPa)
- 17 PORT RELIEF VALVE . . . . . 3500 PSI  
(24132 kPa)
- 18 HYDRAULIC CONTROL VALVE
- 19 BUCKET POSITION VALVE
- 20 FLOW-CONTROL SPOOL
- 21 CHECK VALVE
- 22 PRESSURE RELIEF VALVE
- 23 UN-LOADING SPOOL
- 24 FILTER, Hydraulic . . . . . #10 Micron
- 25 BY-PASS VALVE . . . 72 PSI (496 kPa)
- 26 OIL COOLER
- 27 FILTER, Hydrostatic . . . . . #3 Element
- 28 DIAGNOSTIC COUPLER
- 29 PRESSURE SWITCH, Differential  
S/N 15001-20991 — 19 PSI (131 kPa)  
Starting W/ S/N 20992 — 40 PSI (276 kPa)
- 30 BY-PASS VALVE,  
S/N 15001-20991 — 25 PSI (172 kPa)  
Starting W/ S/N 20992 — 50 PSI (345 kPa)
- 31 DEFUSER
- 32 SCREEN . . . . . 100 Mesh
- 33 BREATHER CAP . . . . . 5 Micron
- 34 HYDROSTATIC PUMPS
- 35 HIGH PRESSURE RELIEF VALVES  
3500 PSI (24133 kPa)

---

## OIL FLOW EXPLANATION

---

The fluid reservoir ① is filled by removing the breather cap ③⑨ and filling fluid through the 100 mesh screen ③② .

Hydraulic fluid flows from the reservoir ① and enters the inlet port of the tandem (2 sections) gear pump ⑨ .

The larger section ⑨<sup>b</sup> of the tandem pump supplies pressure to the inlet of the hydraulic control valve ⑮ . The pump pressure is controlled by the main relief valve ⑮ . The control valve ⑮ is a four-section, open center, closed port, series type valve. When all four spools are in neutral position, the fluid goes through the control valve ⑮ and either to the hydraulic filter ⑳ or to the bucket position valve ⑲ .

The lift section and tilt section of the control valve ⑮ work together to position the bucket as the lift arms of the loader are being raised. When the lift arms are being raised, the hydraulic pump ⑨<sup>b</sup> flow is directed to the base end of the lift cylinders ⑪ . The fluid from the rod end of the lift cylinders ⑪ returns into the bucket position valve ⑲ and is directed to the center of the flow-control spool ㉔ . The flow-control spool ㉔ has an orifice at each end. Fifty nine percent (59%) of the fluid flow is directed to the base end of the tilt cylinder ⑫ . Forty one percent (41%) of the fluid is directed through the opposite end of the flow-control spool ㉔ and to the return port of the control valve ⑮ lift section.

The fifty nine percent (59%) of the fluid flow from the flow-control spool ㉔ is against the un-loading spool ㉓ and a check valve ㉑ . An increase in fluid pressure causes the check valve ㉑ to open which allows the flow of the fluid to the base end of the tilt cylinder ⑫ . The fluid from the rod end of the tilt cylinder ⑫ is contained by the un-loading spool ㉓ until the tilt cylinder base end ⑫ pressure is high enough to open the un-loading spool ㉓ and allow the rod end fluid to return into the control valve ⑮ . The pressure relief valve ㉒ is to relief fluid from the base end of the tilt cylinder ⑫ if the bucket is fully rolled out and lift cylinders ⑪ are still extending.

The fluid flows from the charge pump ⑨<sup>a</sup> either to the oil cooler ㉖ or to the cooler by-pass valve ③ will open when the fluid temperature is low or if there is excessive fluid pressure. The fluid flows through the oil cooler ㉖ , then through the hydrostatic filter ㉗ and into the four-way cross fitting. The fluid flows past the pressure switch ⑧ to the charge by-pass valve ⑤ . The pressure switch ⑧ has a dual function, it starts the hourmeter and turns the warning light off.

Normal flow of fluid is through the four-way cross fitting to the front and rear hydrostatic pumps ④ . This fluid flow is called "charge pressure" and supplies the hydrostatic pumps ④ and the hydrostatic motors ⑦ with charge fluid. The charge fluid is used by the

pump and motor, but as the charge pressure increases, the charge by-pass valve 5 will open to prevent excessive pressure build up.

The charge fluid flows into each pump 34 and motor 7 to cool, lubricate and replenish the fluid supply which is lost through case drain. Case drain from the pumps 34 flows into the inlet side of the hydraulic pump 9 through internal porting.

There are two hydrostatic pumps 34 and two hydrostatic motors 7. One pump and one motor work together as a pair to drive one side of the loader. The other pump and motor work as a pair to drive the opposite side of the loader.

The the swash plates of the hydrostatic pumps 34 are angled in either direction, the pumps 34 force fluid, under pressure, to the motors 7. The motors 7 turn and push the low pressure fluid back to the pumps 34 to be used again. The motors 7 contain a shuttle valve which allows some fluid from the "drive loop" to go to the port block 4 and back to the reservoir 1. The hydrostatic pumps 34 contain four high pressure relief/replenishing valves 35. There are two valves 35 for drive on each side of the loader: one for forward travel and one for reverse travel. The high pressure relief/replenishing valve 35 have a dual function. In neutral the valve cartridges 35 are pushed off their seats to allow fluid flow from the charge loop to cool, lubricate and replenish the pumps and motors. In forward or reverse (when the swashplates are angled), the fluid has a higher pressure than charge fluid. This pressure difference forces one of the high pressure replenishing valves (one per pump) 35 against the seat. The high pressure replenishing valves 35 also act as a high pressure relief valve for the hydrostatic pumps 34. The high pressure replenishing valves 35 will open allowing the "drive pressure" to relieve into the charge loop to be used again if excessive pressure is generated by the pumps 34.

Excess charge pressure fluid which is relieved over the charge by-pass valve 5 goes through the port block 4 and joins the hydrostatic motors 7 case drain fluid and flows to the reservoir 1 through the defusser 31. Fluid from the cold oil by-pass valve 3 flows into the port block 4 and back to the reservoir 1.

Both the hydraulic filter 24 and the hydrostatic filter 27 have a by-pass valves. The hydraulic filter 24 has a 72 PSI (496 kPa) by-pass valve 25. The hydrostatic filter 27 has a 25 PSI (172 kPa) (S/N 15001-20991) or 50 PSI (345 kPa) (Starting at S/N 20992) by-pass valve 30 and also contains a pressure differential switch 29 which indicates the condition of the filter.

The diagnostic coupler 28 provides a quick access for checking the charge pressure.





**bobcat**

# HYDRAULIC / HYDROSTATIC FLOW CHART

For Model

**843 (S/N 26001 Thru 29925)**

Chart #6570552 (Printed May 1989)

- RED - High Pressure
- BLUE - Low Pressure
- GREEN - Case Drain & Reservoir
- ORANGE - Charge Pressure
- LT. ORANGE - Bucket Position Fluid Flow

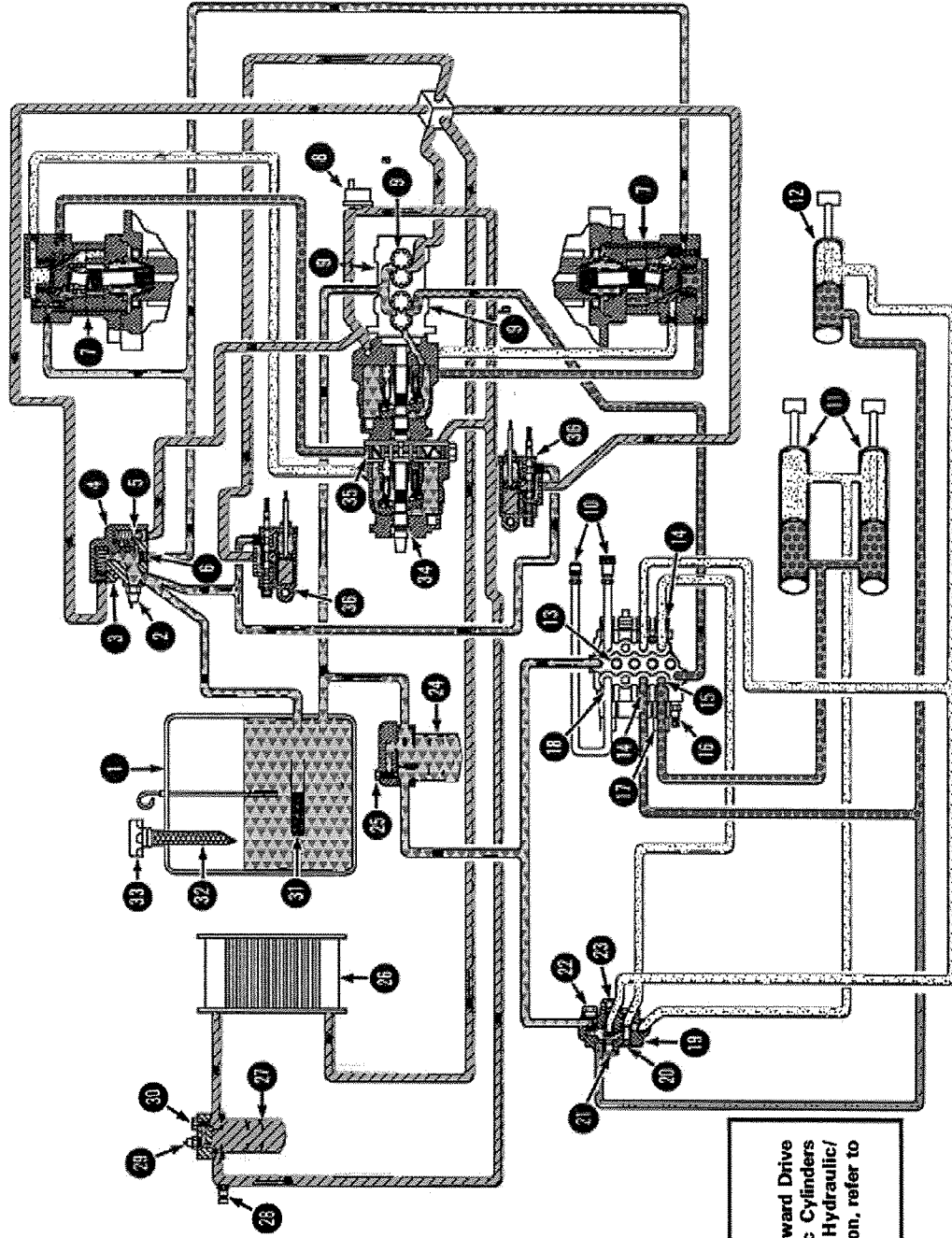

**NOTE**  
 Chart shows oil flow in Forward Drive Position and with Hydraulic Cylinders Partially Extended. For Hydraulic/Hydrostatic System Operation, refer to Sheet 2 of this publication.

6570552 (5-89)

(Sheet 1 of 2)

Printed in U.S.A.

MC-1027



# HYDRAULIC / HYDROSTATIC SYSTEM OPERATION

To Be Used With  
**HYDRAULIC / HYDROSTATIC FLOW CHART**

For Model  
**843 (S/N 26001 Thru 29925)**

Chart #6570552 (Printed May 1989)

## CHART LEGEND

- ① RESERVOIR, Cap.: . . . . . 3.5-4.0 Gals.  
(13,2-15,1 L)
- ② TEMPERATURE SWITCH, . . 225-232°F  
(108-111°C)
- ③ COLD FLUID BY-PASS VALVE, 297 PSI  
(2048 kPa)
- ④ PORT BLOCK
- ⑤ CHARGE BY-PASS VALVE, . . . 110 PSI  
(758 kPa)
- ⑥ ORIFICE . . . Motor Case Drain 0.217"  
(5,51 mm) Dia.
- ⑦ HYDROSTATIC MOTOR
- ⑧ PRESSURE SWITCH (Dual Function),  
Hourmeter Starts @ 19-23 PSI (131-159  
kPa) Warning Light Turns off @ 17-21 PSI  
(117-145 kPa)
- ⑨ HYDRAULIC PUMP, Gear Type
  - a. Charge Pump, 11.5 GPM (43,5 L/min.)  
@ 2700 RPM @ 1050 PSI (7240 kPa)
  - b. Hydraulic Pump, 16.1 GPM (60,9 L/min.)  
@ 2700 RPM @ 1050 PSI (7240 kPa)
- ⑩ HYDRAULIC AUXILIARY LINES
- ⑪ LIFT CYLINDERS
- ⑫ TILT CYLINDER
- ⑬ LOAD CHECK VALVES (Four)
- ⑭ ANTI-CAVITATION CHECK VALVE
- ⑮ ORIFICE
- ⑯ MAIN RELIEF VALVE, . . 2250-2400 PSI  
(15514-16548 kPa)
- ⑰ PORT RELIEF VALVE. . . . . 3500 PSI  
(24133 kPa)
- ⑱ HYDRAULIC CONTROL VALVE
- ⑲ BUCKET POSITION VALVE
- ⑳ FLOW-CONTROL SPOOL
- ㉑ CHECK VALVE
- ㉒ PRESSURE RELIEF VALVE
- ㉓ UN-LOADING SPOOL
- ㉔ FILTER, Hydraulic . . . . . #10 Micron
- ㉕ BY-PASS VALVE . . . 72 PSI (496 kPa)
- ㉖ OIL COOLER
- ㉗ FILTER, Hydrostatic . . . . . #3 Element
- ㉘ DIAGNOSTIC COUPLER
- ㉙ PRESSURE SWITCH, Differential  
S/N 15001-20991 — 19 PSI (131 kPa)  
Starting W/ S/N 20992 — 40 PSI (276 kPa)
- ㉚ BY-PASS VALVE,  
S/N 15001-20991 — 25 PSI (172 kPa)  
Starting W/ S/N 20992 — 50 PSI (345 kPa)
- ㉛ DIFFUSER
- ㉜ SCREEN . . . . . 100 Mesh
- ㉝ BREATHER CAP . . . . . 5 Micron
- ㉞ HYDROSTATIC PUMPS
- ㉟ HIGH PRESSURE RELIEF VALVES  
3500 PSI (24133 kPa)
- ㊱ STEERING SERVO VALVE (2)

## OIL FLOW EXPLANATION

Hydraulic fluid flows from the reservoir ① and enters the inlet port of the tandem (2 sections) gear pump ⑨. The larger section ⑨<sup>b</sup> of the tandem pump supplies pressure to the inlet of the hydraulic control valve ⑱. The pump pressure is controlled by the main relief valve ⑯. The control valve ⑱ is a four-section, open center, closed port, series type valve. When all four spools are in neutral position, the fluid goes through the control valve ⑱ and to the hydraulic filter ⑳.

The lift section and tilt section of the control valve ⑱ work together to position the bucket as the lift arms of the loader are being raised. When the lift arms are being raised, the hydraulic pump ⑨<sup>b</sup> flow is directed to the base end of the lift cylinders ⑪. The fluid from the rod end of the lift cylinders ⑪ returns into the bucket position valve ⑲ and is directed to the center of the flow-control spool ㉔. The flow-control spool ㉔ has an orifice at each end. Forty one percent (41%) of the fluid flow is directed through the opposite end of the flow-control spool ㉔ and to the return port of the control valve ⑱ lift section.

Fifty nine percent (59%) of the fluid flow from the flow-control spool ㉔ is against the un-loading spool ㉓ and a check valve ㉑. An increase in fluid pressure causes the check valve ㉑ to open which allows the flow of the fluid to the base end of the tilt cylinder ⑫. The fluid from the rod end of the tilt cylinder ⑫ is contained by the un-loading spool ㉓ until the tilt cylinder ⑫ base end pressure is high enough to open the un-loading spool ㉓ and allow the rod end fluid to return to the control valve ⑱. The pressure relief valve ㉒ is to relieve fluid from the base end of the tilt cylinder ⑫ if the bucket is fully rolled out and the lift cylinders ⑪ are still being extended.

The fluid from the charge pump section ⑨<sup>a</sup> flows to either the oil cooler ㉖ or to the cooler by-pass valve ③. The cooler by-pass valve ③ will open when the fluid temperature is low (cold) or if there is excessive fluid pressure. The fluid flows through the oil cooler ㉖, then through the hydrostatic filter ㉗ and into the four-way cross fitting. The fluid flows past the pressure switch ⑧ to the charge by-pass valve ⑤. The pressure switch ⑧ has a dual function, it starts the hourmeter and turns the warning light off.

Normal flow of fluid is through the four-way cross fitting to the front and rear hydrostatic pumps ㉘, and also supplies fluid to actuate the steering servo controls ㉚. This fluid flow is called charge pressure fluid. The charge fluid flows into each pump ㉘ and motor ⑦ to cool, lubricate and replenish the fluid supply which is lost through case drain. Case drain from the pumps ㉘ flows into the inlet side of the hydraulic pump ⑨ through internal porting. The return fluid from the steering servos ㉚ flows to the port block ④.

There are two hydrostatic pumps ㉘ and two hydrostatic motors ⑦. One pump and one motor work together as a pair to drive one side of the loader. The other pump and motor work as a pair to drive the opposite side of the loader.



The swash plates of the hydrostatic pumps 34 are angled by the steering servo valves 36 in either direction, the pumps 34 force fluid, under pressure, to the motors 7. The motors 7 turn and push the low pressure fluid back to the pumps 34 to be used again. The motors 7 contain a shuttle valve which allows some fluid from the drive loop to go to the port block 4 and back to the reservoir 1. The hydrostatic pumps 34 contain four high pressure relief/replenishing valves 35. There are two valves 35 for drive on each side of the loader: one for forward travel and one for reverse travel. The high pressure relief/replenishing valves 35 have a dual function. The valve cartridges 35 are pushed off their seats to allow fluid flow from the charge loop to cool, lubricate and replenish the pumps and motors. In forward or reverse (when the swash plates are angled), the fluid has a higher pressure than charge fluid. This pressure difference forces the high pressure replenishing valves 35 onto the seat. The high pressure replenishing valve 35 will open allowing the drive pressure to relieve into the charge loop to be used again if excessive pressure is generated by the pumps 34.

Excess charge pressure fluid which is relieved over the charge by-pass valve 5 goes through the port block 4 and joins the hydrostatic motors 7 case drain and flows to the reservoir 1 through the diffuser 31. Fluid from the cold oil by-pass valve 3 flows into the port block 4 and back to the reservoir 1 under conditions of cold fluid or excess flow.

The hydraulic filter 24 has a by-pass valves to protect the system if the filter element becomes plugged. The hydrostatic filter 27 has a by-pass valve and a pressure differential switch 28 which indicates the condition of the filter element.

The diagnostic coupler 28 provides a quick access for checking the charge pressure in the system.





# HYDRAULIC / HYDROSTATIC FLOW CHART

For Model

## 843 (S/N 29926 & Above)

Chart #6720178 (Printed May 1989)

- RED - High Pressure
- BLUE - Low Pressure
- GREEN - Case Drain & Reservoir
- ORANGE - Charge Pressure
- LT. ORANGE - Bucket Position Fluid Flow

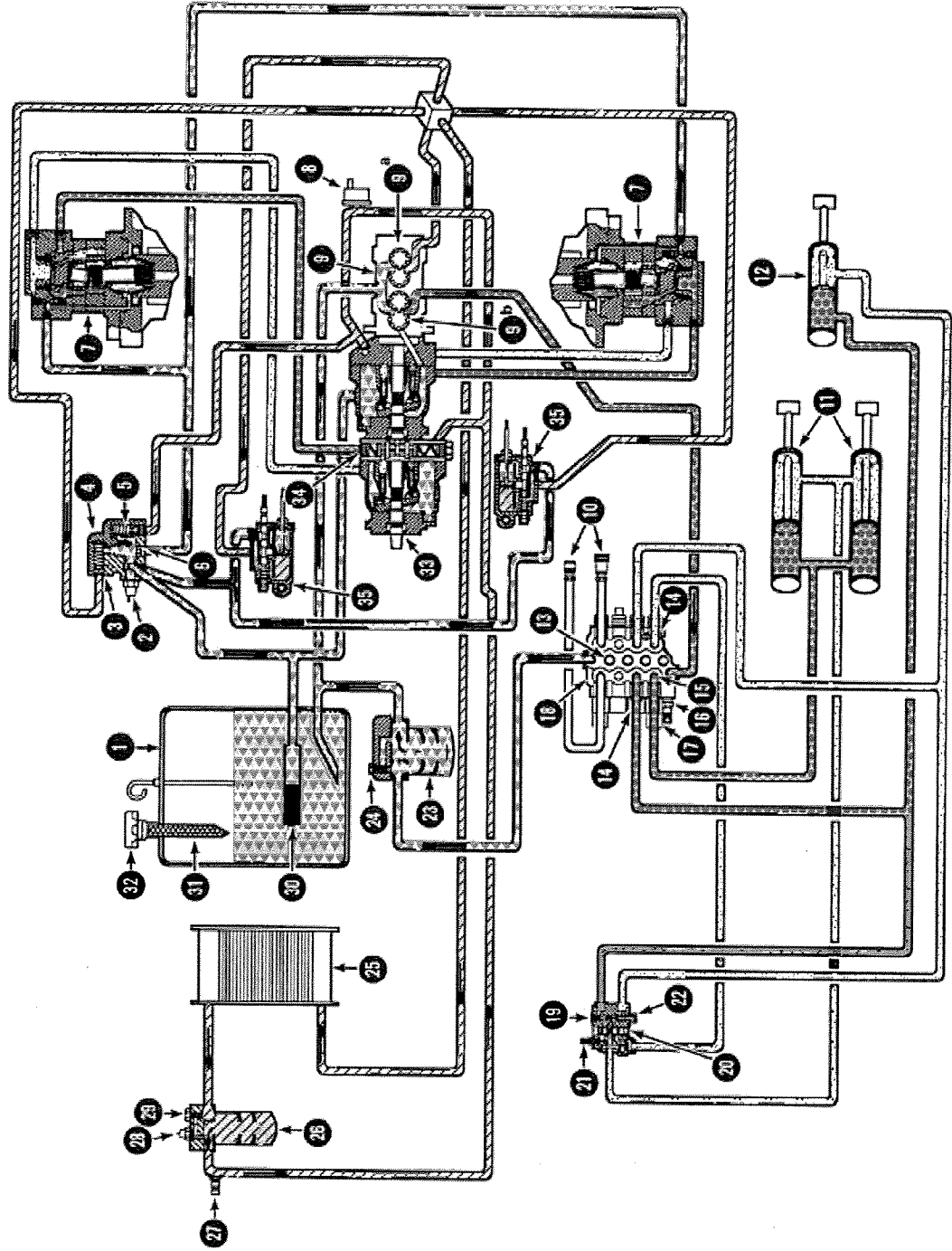

MC1252

Printed in U.S.A.

(Sheet 1 of 2)

6720178 (5-89)



# HYDRAULIC / HYDROSTATIC SYSTEM OPERATION

To Be Used With  
**HYDRAULIC / HYDROSTATIC FLOW CHART**

For Model  
**843 (S/N 29926 & Above)**  
Chart #6720178 (Printed May 1989)

## CHART LEGEND

- 1 RESERVOIR, Cap.: . . . . . 3.5-4.0 Gals.  
(13,2-15,1 L)
- 2 TEMPERATURE SWITCH, . 225-232°F  
(108-111°C)
- 3 COLD FLUID BY-PASS VALVE, 297 PSI  
(2048 kPa)
- 4 PORT BLOCK
- 5 CHARGE BY-PASS VALVE, . . . . 110 PSI  
(758 kPa)
- 6 ORIFICE . . . Motor Case Drain 0.217"  
(5,51 mm) Dia.
- 7 HYDROSTATIC MOTOR
- 8 PRESSURE SWITCH (Dual Function),  
Hourmeter Starts @ 19-23 PSI (131-159  
kPa) Warning Light Turns off @ 17-21 PSI  
(117-145 kPa)
- 9 HYDRAULIC PUMP, Gear Type
  - a. Charge Pump, 11.5 GPM (43,5 L/min.)  
@ 2700 RPM @ 1050 PSI (7240 kPa)
  - b. Hydraulic Pump, 16.1 GPM (60,9 L/min.)  
@ 2700 RPM @ 1050 PSI (7240 kPa)
- 10 HYDRAULIC AUXILIARY LINES
- 11 LIFT CYLINDERS
- 12 TILT CYLINDER
- 13 LOAD CHECK VALVES (Four)
- 14 ANTI-CAVITATION CHECK VALVE
- 15 ORIFICE
- 16 MAIN RELIEF VALVE, . 2250-2400 PSI  
(15514-16548 kPa)
- 17 PORT RELIEF VALVE . . . . . 3500 PSI  
(24133 kPa)
- 18 HYDRAULIC CONTROL VALVE
- 19 BUCKET POSITION VALVE
- 20 FLOW-CONTROL SPOOL
- 21 FLOW ADJUSTMENT VALVE
- 22 UN-LOADING SPOOL
- 23 FILTER, Hydraulic . . . . . #10 Micron
- 24 BY-PASS VALVE . . . . 72 PSI (496 kPa)
- 25 OIL COOLER
- 26 FILTER, Hydrostatic . . . . . #3 Element
- 27 DIAGNOSTIC COUPLER
- 28 PRESSURE SWITCH, Differential  
40 PSI (276 kPa)
- 29 BY-PASS VALVE . . . . 50 PSI (345 kPa)
- 30 DIFFUSER
- 31 SCREEN . . . . . 100 Mesh
- 32 BREATHER CAP . . . . . 5 Micron
- 33 HYDROSTATIC PUMPS
- 34 HIGH PRESSURE RELIEF VALVES  
3500 PSI (24133 kPa)
- 35 STEERING SERVO VALVE (2)

## OIL FLOW EXPLANATION

Hydraulic fluid flows from the reservoir ① and enters the inlet port of the tandem (2 sections) gear pump ⑨. The larger section ⑨<sup>b</sup> of the tandem pump supplies pressure to the inlet of the hydraulic control valve ⑱. The pump pressure is controlled by the main relief valve ⑯. The control valve ⑱ is a four-section, open center, closed port, series type valve. When all four spools are in neutral position, the fluid goes through the control valve ⑱ and to the hydraulic filter ㉓.

The lift section and tilt section of the control valve ⑱ work together to position the bucket as the lift arms, of the loader, are being raised. When the lift arms are being raised, the hydraulic pump ⑨<sup>b</sup> fluid flow is directed to the base end of the lift cylinders ⑪. The fluid from the rod end of the lift cylinders ⑪ returns to the bucket position valve ⑲ and is directed to the center of the flow-control spool ㉒. The flow-control spool ㉒ and adjustable metering orifice ㉑ split this flow. Fifty-nine percent (59%) of the fluid flow is directed over the metering orifice ㉑ to level the bucket. Forty-one percent (41%) of the fluid is directed through the orifice in the flow-control spool ㉒ and on to the return port of the control valve (lift section) ⑱.

Fifty nine percent (59%) of the fluid flow from the flow-control spool ㉒ and metering orifice ㉑ is against the un-loading spool ㉔. The un-loading spool moves to allow extension of the tilt cylinder ⑫ as the lift cylinders ⑪ raise the lift arms.

The fluid from the charge pump section ⑨<sup>a</sup> flows to either the oil cooler ㉕ or to the cooler by-pass valve ③. The cooler by-pass valve ③ will open when the fluid temperature is low (cold) or if there is excessive fluid pressure. The fluid flows through the oil cooler ㉕, then through the hydrostatic filter ㉖ and into the four-way cross fitting. The fluid flows past the pressure switch ⑥ to the charge by-pass valve ⑤. The pressure switch ⑥ has a dual function, it starts the hourmeter and turns the warning light off.

Normal flow of fluid is through the four-way cross fitting to the front and rear hydrostatic pumps ㉗, and also supplies fluid to actuate the steering servo controls ㉙. This fluid flow is called charge pressure fluid. The charge fluid flows into each pump ㉗ and motor ⑦ to cool, lubricate and replenish the fluid supply which is lost through case drain. Case drain from the pumps ㉗ flows into the inlet side of the hydraulic pump ⑨ through internal porting. The return fluid from the steering servos ㉙ flows to the port block ④.

There are two hydrostatic pumps ㉗ and two hydrostatic motors ⑦. One pump and one motor work together as a pair to drive one side of the loader. The other pump and motor work as a pair to drive the opposite side of the loader.

The swash plates of the hydrostatic pumps ㉗ are angled by the steering servo valves ㉙ in either direction, the pumps ㉗ force fluid, under pressure, to the motors ⑦. The motors ⑦ turn and push the low pressure fluid back to the pumps ㉗ to be used again. The motors

7 contain a shuttle valve which allows some fluid from the drive loop to go to the port block 4 and back to the reservoir 1 . The hydrostatic pumps 33 contain four high pressure relief/replenishing valves 34 . There are two valves 34 for drive on each side of the loader: one for forward travel and one for reverse travel. The high pressure relief/replenishing valves 34 have a dual function. The valve cartridges 34 are pushed off their seats to allow fluid flow from the charge loop to cool, lubricate and replenish the pumps and motors. In forward or reverse (when the swash plates are angled), the fluid has a higher pressure than charge fluid. This pressure difference forces the high pressure replenishing valves 34 onto the seat. The high pressure replenishing valve 34 will open allowing the drive pressure to relieve into the charge loop to be used again if excessive pressure is generated by the pumps 33 .

Excess charge pressure fluid which is relieved over the charge by-pass valve 5 goes through the port block 4 and joins the hydrostatic motors 7 case drain and flows to the reservoir 1 through the diffuser 30 . Fluid from the cold oil by-pass valve 3 flows into the port block 4 and back to the reservoir 1 under conditions of cold fluid or excess flow.

The hydraulic filter 23 has a by-pass valve 24 to protect the system if the filter element becomes plugged. The hydrostatic filter 26 has a by-pass valve 29 and a pressure differential switch 26 which indicates the condition of the filter element.

The diagnostic coupler 27 provides a quick access for checking the charge pressure in the system.



# HYDRAULIC / HYDROSTATIC FLOW CHART AND WIRING DIAGRAM

For Model

## 843 HIGH HORSEPOWER HYDRAULICS (OPTIONAL)

Chart #6570916 (Printed May 1989)



- RED - High Pressure
- BLUE - Low Pressure
- GREEN - Case Drain & Reservoir
- ORANGE - Charge Pressure
- LT. ORANGE - Bucket Position Fluid Flow

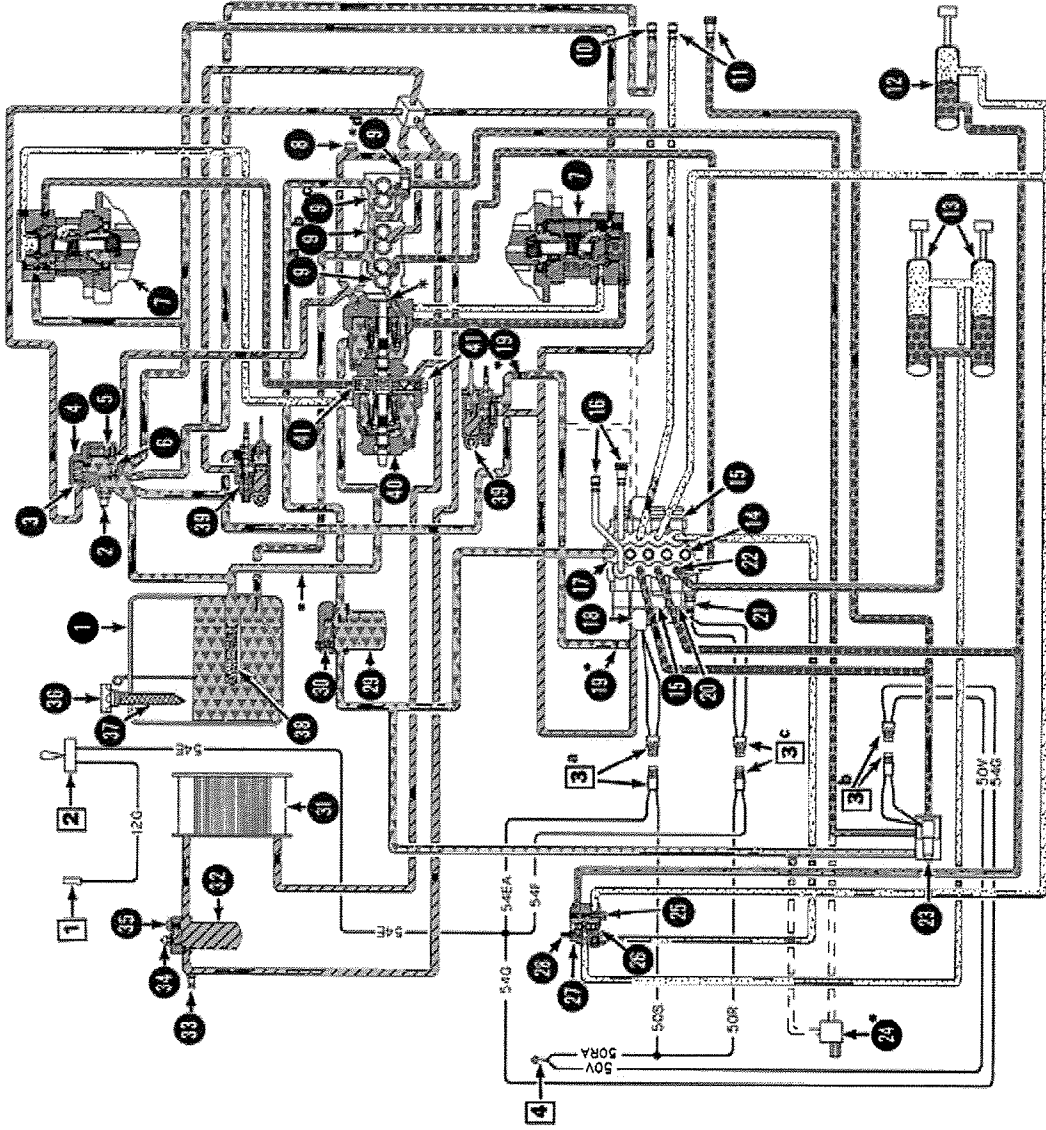

### NOTE

Chart shows fluid flow in Forward Drive Position and with Hydraulic Cylinders Partially Extended.

\* THE LATER PRODUCTION LOADER WITH HIGH HORSEPOWER HYDRAULICS (OPTION) MAY BE DIFFERENT THAN THE EARLY PRODUCTION LOADERS, AS LISTED BELOW:

- 1 Orifice, could be in either location shown on the chart, but not in both.
- 2 External relief valve was replaced by internal relief valve 6 in the end cap of the hydraulic pump.
- 3 Case drain hose was added from the hydrostatic pump 4 to the hydraulic reservoir 5 and the internal port between the hydraulic pump and hydrostatic pumps was removed on later production loaders.

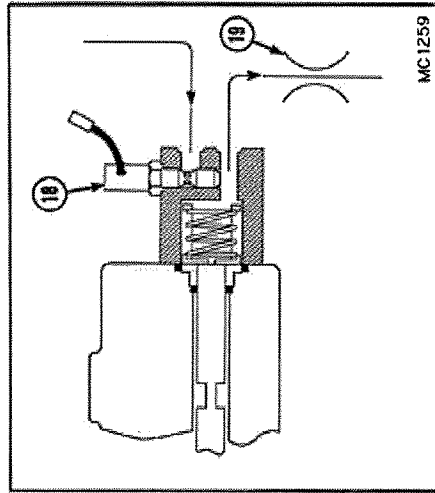

MC1259

6570916 (5-89)

(Sheet 1 of 2)

Printed in U.S.A.

MC-1124





# HYDRAULIC / HYDROSTATIC SYSTEM OPERATIONS

To Be Used With

## HYDRAULIC / HYDROSTATIC FLOW CHART AND WIRING DIAGRAM

For Model

### 843 HIGH HORSEPOWER HYDRAULICS (OPTIONAL)

Chart #6570916 (Printed September 1990)

#### CHART LEGEND

- 1 RESERVOIR, Capacity: . . . 3.5-4.0 Gals.  
(13,2-15,1 L)
- 2 TEMPERATURE SWITCH, . . . 225-232°F  
(100-111°C)
- 3 COLD FLUID BY-PASS VALVE, 297 PSI  
(2048 kPa)
- 4 PORT BLOCK
- 5 CHARGE BY-PASS VALVE, . . . 110 PSI  
(758 kPa)
- 6 ORIFICE . . . Motor Case Drain 0.217"  
(5,5 mm) Diameter
- 7 HYDROSTATIC MOTOR
- 8 PRESSURE SWITCH (Dual Function),  
Hourmeter Starts @ 19-23 PSI (132-158  
kPa) Warning Light Turns off @ 17-21  
PSI (118-144 kPa)
- 9 HYDRAULIC PUMP, Gear Type – Rated  
@ 2700 RPM @ 1050 PSI (7239 kPa)  
a. Hydraulic Pump, 16.2 GPM (61,3 L/min.)  
b. Charge Pump, 10.8 GPM (40,9 L/min.)  
c. Auxiliary Hydraulic Pump, 6.9 GPM  
(26,1 L/min.)  
d. \*Relief Valve, 3000 PSI (20685 kPa)
- 10 AUXILIARY COUPLER, Case Fluid Drain
- 11 AUXILIARY COUPLERS, . . . . . High  
Horsepower Flow
- 12 TILT CYLINDER
- 13 LIFT CYLINDERS
- 14 LOAD CHECK VALVES, . . . . . 3
- 15 ANTI-CAVITATION VALVE
- 16 AUXILIARY QUICK COUPLERS
- 17 HYDRAULIC CONTROL VALVE
- 18 SOLENOID VALVE, . . High Horsepower  
Control
- 19 \*ORIFICE, . . . . . 0.024" (0,61 mm) Dia.
- 20 PORT RELIEF VALVE, . . . . . 3500 PSI  
(24132 kPa)
- 21 MAIN RELIEF VALVE (Electrical Controlled),  
Normal Operation; 2200 PSI (15159 kPa)  
High Horsepower Operation; 3000 PSI  
(20685 kPa)
- 22 ORIFICE
- 23 ELECTRICAL SELECTOR VALVE
- 24 \*RELIEF VALVE, 3000 PSI (20685 kPa)
- 25 UN-LOADING SPOOL
- 26 FLOW CONTROL SPOOL
- 27 BUCKET POSITION VALVE
- 28 FLOW ADJUSTMENT VALVE
- 29 FILTER, . . . . . Hydraulic #4 Element
- 30 BY-PASS VALVE, . . . . . 72 PSI (496 kPa)
- 31 OIL COOLER
- 32 FILTER, . . . . . Hydrostatic #3 Element
- 33 DIAGNOSTIC COUPLER
- 34 PRESSURE SWITCH, Differential 40 PSI  
(276 kPa)
- 35 BY-PASS VALVE, . . . . . 50 PSI (345 kPa)
- 36 BREATHER CAP, . . . . . 5 Micron
- 37 SCREEN, . . . . . 100 Mesh
- 38 DIFFUSER
- 39 STEERING SERVO CONTROL
- 40 HYDROSTATIC PUMPS
- 41 HIGH PRESSURE RELIEF VALVES, 3500  
PSI (24133 kPa)

## WIRE DIAGRAM LEGEND

NO.'s	COLOR	GAUGE
12G	Orange/White	16
50R	Black	16
50RA	Black	16
50S	Black	16
50V	Black	16
54E	Dk. Green	16
54EA	Dk. Green	16
54F	Dk. Green	16
54G	Dk. Green	16

## WIRING DIAGRAM PARTS LEGEND

- 1 Harness Connector
- 2 Switch
- 3 Solenoid Connectors
- 4 Ground

### CHECKING & ADJUSTING MAIN RELIEF VALVE (DUAL PRESSURE)

1. Lift and block the loader.
2. Connect the hydraulic tester to the quick couplers 16.
3. Disconnect the electrical connectors 3<sup>a</sup> and 3<sup>b</sup>.
4. Start the engine. Check the main relief valve 21 pressure.
5. Engage the high flow hydraulics switch 2.

**NOTE:** If the pressure relief setting is adjusted, it will effect the standard relief pressure. Always adjust the high pressure setting first.

6. If adjustment is needed, loosen the jam nut and adjust the high flow relief valve pressure by turning in to increase pressure or out to decrease pressure. The correct setting is 2950-3030 PSI (20340-21030 kPa).
7. Disengage the high flow hydraulics. Stop the engine. tighten the jam nut to 35 ft.-lbs. (47 Nm) torque.
8. Remove the access plug or loosen the jam nut on the main relief valve 21.
9. Start the engine. Use an allen wrench and turn the screw in to increase pressure or out to decrease pressure. The correct setting is 2150-2250 PSI (14824-15514 kPa).
10. Stop the engine. Install the access plug or tighten the jam nut. Disconnect the hydraulic tester.

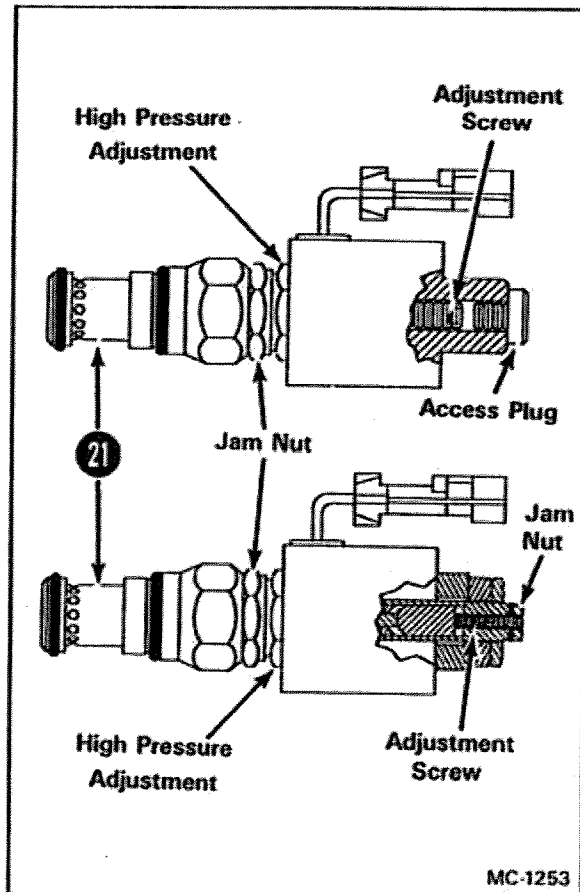

11. To check the relief valve in the hydraulic pump 9<sup>d</sup> end section: connect the hydraulic tester into the outlet line of the pump 9<sup>c</sup>. By restricting the flow, with the hydraulic tester, the pressure should be 3000 PSI (20685 kPa) at the relief valve 9<sup>d</sup>.



**bobcat**

# HYDRAULIC / HYDROSTATIC FLOW CHART AND WIRING DIAGRAM

For Model

## 843H (With Pilot Operated Main Relief)

Chart #6722305 (Printed September 1992)

- RED - High Pressure
- BLUE - Low Pressure
- GREEN - Case Drain & Reserv
- ORANGE - Charge Pressure
- LT. ORANGE - Bucket Position Fluid

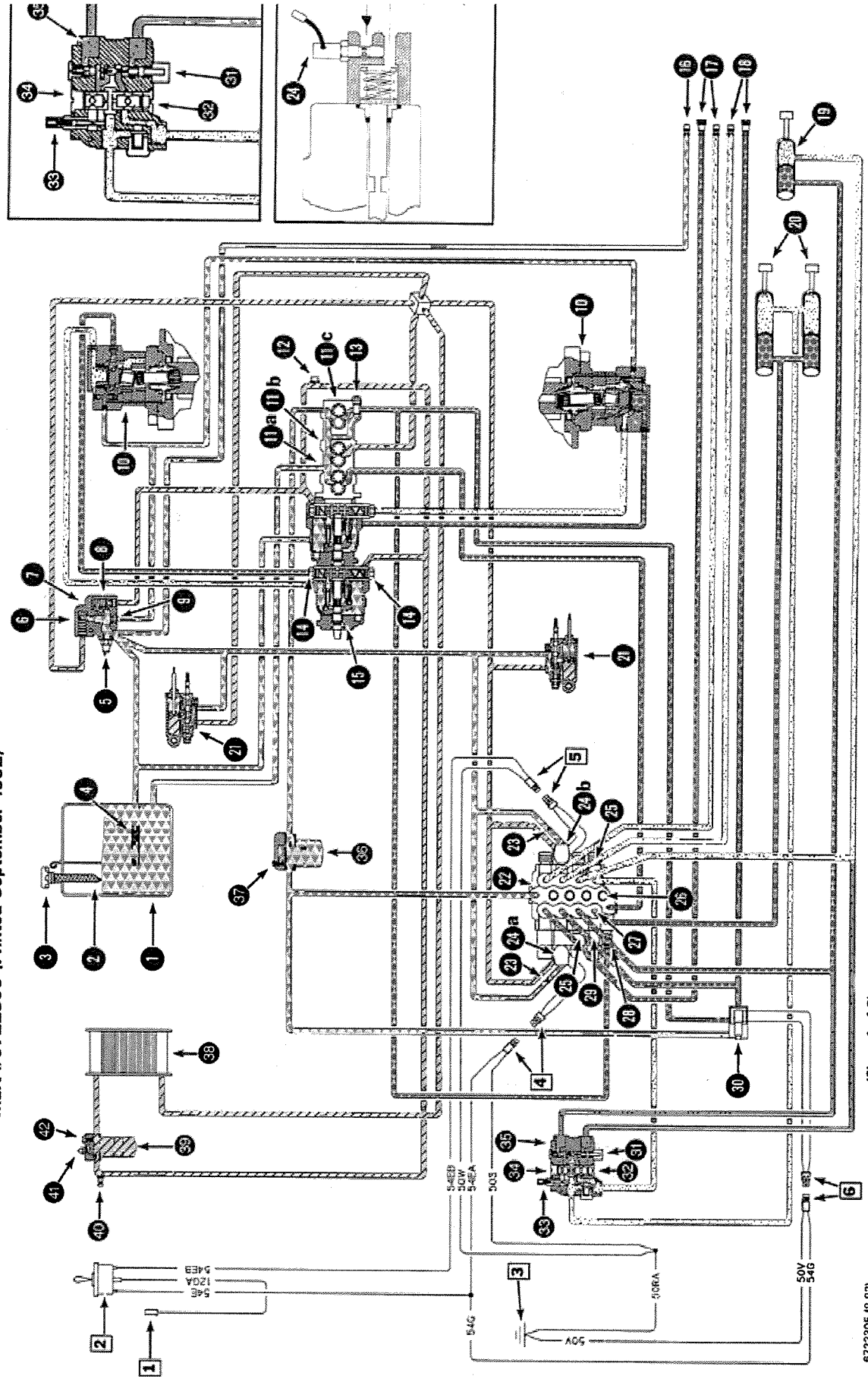

Printed in U.S.A.

(Sheet 1 of 2)

6722305 (9-92)



# HYDRAULIC / HYDROSTATIC SYSTEM OPERATIONS

To Be Used With

## HYDRAULIC / HYDROSTATIC FLOW CHART AND WIRING DIAGRAM

For Model

### 843H (With Pilot Operated Main Relief)

Chart #6722305 (Printed September 1992)

#### CHART LEGEND

- 1 RESERVOIR, Cap.: . . . . . 3.5-4.0 Gals.  
(13,2-15,1 L)
- 2 SCREEN, . . . . . 60 Mesh
- 3 BREATHER CAP, . . . . . 5 Micron
- 4 DIFFUSER
- 5 TEMPERATURE SWITCH, . . . . . 225-232°F.  
(100-111°C.)
- 6 COLD FLUID BY-PASS VALVE, 297 PSI  
(2048 kPa)
- 7 PORT BLOCK
- 8 CHARGE BY-PASS VALVE, 180-200 PSI  
(1241-1379 kPa)
- 9 ORIFICE, . . . Motor Case Drain 0.217"  
(5,5 mm) Diameter
- 10 HYDROSTATIC MOTOR
- 11 HYDRAULIC PUMP, . Gear Type-Rated  
@ 2700 RPM
  - a. Hydraulic Pump, 16.2 GPM (61,3 L/min.)
  - b. Charge Pump, 10.8 GPM (40,9 L/min.)
  - c. Auxiliary Hydraulic Pump,  
6.9 GPM (26,1 L/min.)
- 12 PRESSURE SWITCH (Dual Function),  
Hourmeter Starts @ 19-23 PSI  
(131-159 kPa); Warning Light Turns  
Off @ 17-21 PSI (117-145 kPa)
- 13 RELIEF VALVE, 3000 PSI (20685 kPa)
- 14 HIGH PRESSURE RELIEF/REPLENISHING  
VALVES (4), . . . 3500 PSI (24133 kPa)
- 15 HYDROSTATIC PUMPS
- 16 AUXILIARY COUPLER, . . . Case Drain
- 17 AUXILIARY QUICK COUPLERS
- 18 AUXILIARY COUPLERS, . . . . . High  
Horsepower Flow
- 19 TILT CYLINDER
- 20 LIFT CYLINDERS
- 21 STEERING SERVO CONTROL
- 22 HYDRAULIC CONTROL VALVE
- 23 ORIFICE, . . . 0.024" (0,61 mm) Dia.
- 24 SOLENOID VALVE, . High Horsepower
  - a. Forward Flow Fluid Control (High Flow)
  - b. Reverse Flow Fluid Control (Low Flow)
- 25 ANTI-CAVITATION VALVE
- 26 LOADER CHECK VALVES, . . . . . 3
- 27 ORIFICE
- 28 MAIN RELIEF VALVE, Pilot Operated  
Normal Operation;  
2250-2400 PSI (15514-16548 kPa)  
High Flow Control;  
3000 PSI (20685 kPa)
- 29 PORT RELIEF VALVE, . . . . . 3500 PSI  
(24133 kPa)
- 30 ELECTRICAL SELECTOR VALVE
- 31 UN-LOADING SPOOL / PRESS. RELIEF  
VALVE
- 32 FLOW CONTROL SPOOL
- 33 FLOW ADJUSTMENT VALVE
- 34 CHECK VALVE
- 35 BUCKET POSITION VALVE
- 36 FILTER, . . . . . Hydraulic #4 Element
- 37 BY-PASS VALVE, . . . 72 PSI (496 kPa)
- 38 OIL COOLER
- 39 FILTER, . . . . . Hydrostatic #3 Element
- 40 DIAGNOSTIC COUPLER
- 41 PRESSURE SWITCH, . . . . . Differential  
40 PSI (276 kPa)
- 42 BY-PASS VALVE, . . . 50 PSI (345 kPa)

## WIRE LEGEND

NO.'s	COLOR	GAUGE
12G	Orange/White	16
50RA	Black	16
50S	Black	16
50V	Black	16
50W	Black	16
54E	Dk. Green	16
54EA	Dk. Green	16
54EB	Dk. Green/Yellow	16
54G	Dk. Green	16

## PARTS LEGEND

- 1** Harness Connector
- 2** Switch
- 3** Ground
- 4** Solenoid Connector (Forward Flow)
- 5** Solenoid Connector (Reverse Flow)
- 6** Electrical Selector Valve Connector

### CHECKING & ADJUSTING MAIN RELIEF VALVE (DUAL PRESSURE)

1. Lift & block the loader.
2. Connect the hydraulic tester to the quick couplers **17**. All tests are done with engine speed at full RPM.
3. Start the engine. Check main relief valve pressure. The correct pressure for the low setting is 2250-2400 PSI (15514-16548 kPa).
4. Engage the "high pressure" function & check the high flow pressure. The correct pressure for the high setting is 3000 PSI (20685 kPa).

**NOTE:** If adjustment is necessary, adjust the low pressure setting before adjusting the high pressure setting.

5. Stop the engine. To adjust the low pressure on the main relief valve **28**, use the following procedure:
  - a. Disconnect the pilot hose & remove the adapter fitting.
  - b. Remove the high pressure adjustment housing (Item 1) **A**.
  - c. Use a 1/4" allen wrench (Item 2) to turn the adjusting screw (Item 3) in to increase or out to decrease pressure **A**. One turn is equal to approximately 490 PSI (3379 kPa).
  - d. Install the high pressure adjustment housing & adapter. Connect the pilot hose.
  - e. Start the engine and check the pressure setting. Repeat the procedure until the pressure setting is correct.

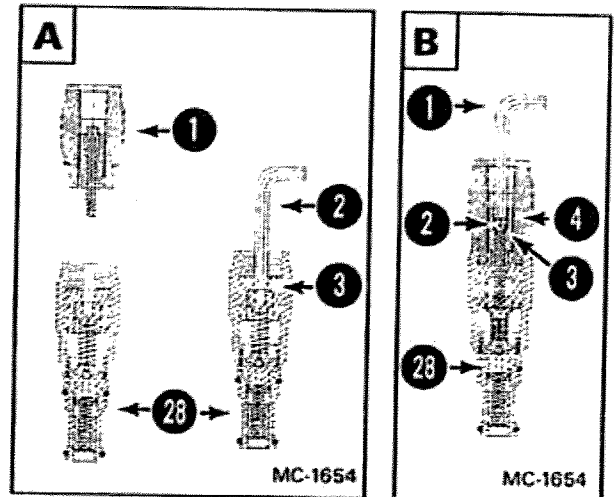

6. When the low pressure setting is correct, the next step is to set the high pressure adjustment of the main relief valve **28**, use the following procedure:
  - a. Stop the engine. Disconnect the pilot hose & remove the adapter.
  - b. Use a 1/4" allen wrench (Item 1) to press the push pin (Item 2) in until it bottoms out against the shoulder stop (Item 3) **B**.
  - c. Turn the adjusting guide (Item 4) in to increase or out to decrease the pressure **B**. One turn is equal to approximately 390 PSI (2689 kPa).
  - d. Install the adapter & connect the pilot hose.
  - e. Start the engine. Engage the "high horsepower" function and check for the correct pressure. Repeat the procedure until the pressure setting is correct.

Hydraulic fluid flows from the reservoir ① and enters the inlet port of the triple (3 section) gear pump ⑪ . The larger section ⑪ <sup>a</sup> of the pump supplies flow to the inlet of the hydraulic control valve ⑫ . The pump pressure is controlled by the main relief valve ⑬ . The control valve ⑫ is a four-section, open center, closed port, series type valve. When all four spools are in neutral position, the fluid goes through the control valve ⑫ and to the hydraulic filter ⑭ .

When the lift arms are raised, the hydraulic pump ⑪ <sup>a</sup> fluid flow is directed to the base end of the lift cylinders ⑮ . The fluid from the rod end of the lift cylinders ⑮ returns to the bucket position valve ⑯ and is directed to the center of the flow-control spool ⑰ . The flow-control spool ⑰ and flow adjustment valve ⑱ direct this flow. A percentage of the fluid is directed over the flow adjustment valve ⑱ to position the bucket. The rest of the fluid is directed through the orifice in the flow-control spool ⑰ and onto the return port of the control valve ⑫ (lift section).

The fluid flow from the flow-control spool ⑰ and flow adjustment valve ⑱ are against the un-loading spool/pressure relief valve ⑲ . The un-loading spool/pressure relief valve ⑲ moves to allow extension of the tilt cylinder ⑳ as the lift cylinders ⑮ raise the lift arms.

The un-loading spool/pressure relief valve ⑲ is to relief fluid from the base end of the tilt cylinder ⑳ if the bucket is fully rolled out and the lift cylinders ⑮ are still extending.

The fluid from the charge pump ⑪ <sup>b</sup> flows to the four-way cross fitting and is called "charge pressure fluid". The fluid flows to the oil cooler ⑳ or oil cooler by-pass valve ② . The oil cooler by-pass valve ② will open when the fluid temperature is cold or if there is excessive fluid pressure. The fluid flows through the oil cooler ⑳ , then through the hydrostatic filter ④ and past the pressure switch ⑫ to supply the front and rear hydrostatic pump ⑮ with charge pressure and on to the charge by-pass valve ⑧ . The pressure switch ⑫ has a dual function, it starts the hourmeter and turns the warning light off. The charge pressure fluid flows into each pump ⑮ and motor ⑩ to cool, lubricate and replenish the fluid supply which has been lost through case drain. Also fluid from the four-way cross fitting supplies fluid to actuate the steering servo controls ⑳ and the electrical solenoids ㉔ for high horsepower operation. The return fluid from the steering servo controls ㉑ and electrical solenoids ㉔ flows to the port block ⑦ .

There are two hydrostatic pumps ⑮ and two hydrostatic motors ⑩ . One pump and one motor work together as a pair to drive one side of the loader. The other pump and motor work as a pair to drive the opposite side of the loader.

The swash plates of the hydrostatic pumps ⑮ are angled by the steering servo controls ㉑ in either direction, the pumps ⑮ force fluid, under pressure, to the motors ⑩ . The motors ⑩ turn and push the low pressure fluid back to the pumps ⑮ to be used again. The motors ⑩ contain a shuttle valve which allows some fluid from the drive loop to go to the port block ⑦ and back to the reservoir ① . The hydrostatic pumps ⑮ contain four high pressure relief/replenishing valves ㉒ . There are two valves ㉒ for drive on each side of the loader: one for forward travel and one for reverse travel. The high pressure relief/replenishing valves ㉒ have a dual function. The valve cartridges ㉒ are pushed off their seats to allow fluid flow from the charge loop to cool, lubricate and replenish the

pumps 15 and motors 10 . In forward or reverse (when the swash plates are angled), the fluid has a higher pressure the charge fluid. This pressure difference forces the high pressure replenishing valve 14 onto the seat. The high pressure replenishing valve 14 will open allowing the drive pressure to relieve into the charge loop to be used again if excessive pressure is generated by the pumps 15 .

Excess charge pressure fluid which is relieved over the charge by-pass valve 8 goes through the port block 7 and joins the hydrostatic motors 10 case drain and flows to the reservoir through the diffuser 4 . Fluid from the cold oil by-pass valve 6 flows into the port block 7 and back to the reservoir 1 under conditions of cold fluid or excess flow.

The hydraulic filter 36 has a by-pass valve 37 to protect the system if the filter element becomes plugged. The hydrostatic filter 39 has a by-pass valve 42 to protect the system if the filter element becomes plugged and a pressure differential switch 41 which indicates the condition of the filter element.

The diagnostic coupler 40 provides a quick access for checking the charge pressure in the system.

## HIGH FLOW OPERATION

Turning the switch 2 "ON" for high flow operation will activate the following functions: it will energize the electrical solenoid 24 a, and the electrical selector valve 30 . When the electrical solenoid 24 a is energized the charge pressure will shift the control valve spool 22 to allow the fluid flow from the hydraulic pump 11 a to flow to the electrical selector valve 30 where the fluid joins with the fluid from the auxiliary hydraulic pump 11 c . This fluid then flows to the high flow quick coupler 16 at the front of the loader. The return fluid flows to the control valve 22 and to the hydraulic filter 37 . Case drain fluid (Example: Planer) will return through the coupler 16 and back to the port block 7 to join the fluid going to the reservoir 1 .

When the high flow operation is engaged; it will engage the pilot operated main relief valve 28 which will increase the relief pressure to 3000 PSI (20685 kPa). The relief valve 13 in the auxiliary hydraulic pump 11 c and main relief valve 28 will open to relieve excessive pressure.

The fluid from the auxiliary hydraulic pump 11 c when not in use, flows to the electrical selector valve 30 and returns to the hydraulic filter 37 .

Turning the switch 2 "REV" for reverse operation will active the electrical solenoid 24 b and shift the control valve spool 22 to allow fluid flow from the hydraulic pump 11 a to flow to the high flow coupler 17 . The return fluid goes to the control valve 22 and to the hydraulic filter 37 . The electrical selector valve 30 is not energized in this function.

# HYDRAULIC / HYDROSTATIC FLOW CHART AND WIRING DIAGRAM

For Model

**843H (S/N 50450 & Above)**

Chart #6720945 (Printed September 1991)



- RED - - - - - High Pressure
- BLUE - - - - - Low Pressure
- GREEN - - - - - Case Drain & Reservoir
- ORANGE - - - - - Charge Pressure
- LT. ORANGE - - - - - Bucket Position Fluid Flow

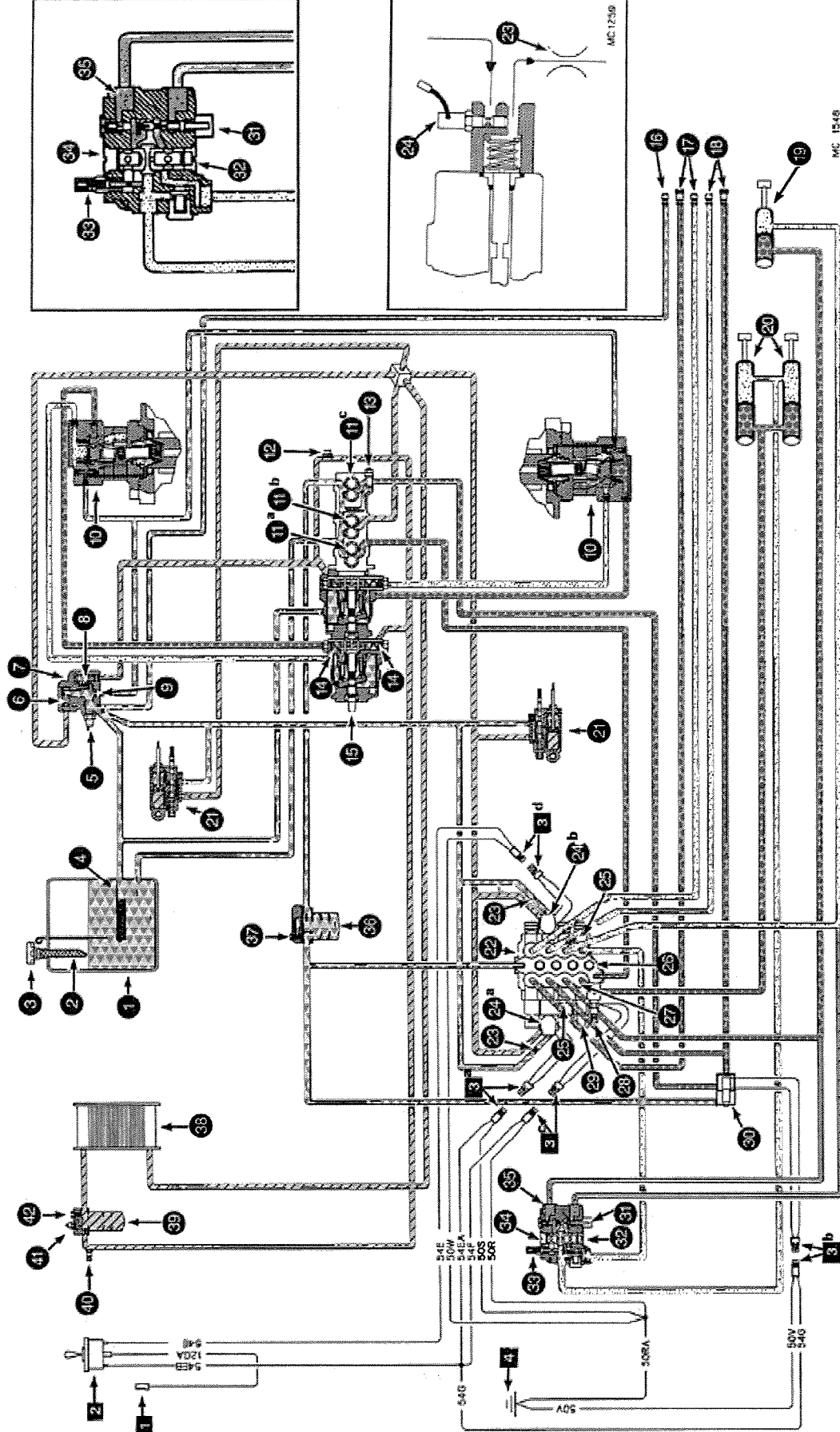

Printed in U.S.A.

(Sheet 1 of 2)

6720945 (9-91)





# HYDRAULIC / HYDROSTATIC SYSTEM OPERATIONS

To Be Used With  
**HYDRAULIC / HYDROSTATIC FLOW CHART AND WIRING DIAGRAM**

For Model  
**843H (S/N 50450 & Above)**

Chart #6720945 (Printed September 1991)

## CHART LEGEND

- ① RESERVOIR, Cap.: . . . . . 3.5-4.0 Gals.  
(13,2-15,1 L)
- ② SCREEN, . . . . . 60 Mesh
- ③ BREATHER CAP, . . . . . 5 Micron
- ④ DIFFUSER
- ⑤ TEMPERATURE SWITCH, . . . . . 225-232°F.  
(100-111°C.)
- ⑥ COLD FLUID BY-PASS VALVE, 297 PSI  
(2048 kPa)
- ⑦ PORT BLOCK
- ⑧ CHARGE BY-PASS VALVE, 180-200 PSI  
(1241-1379 kPa)
- ⑨ ORIFICE, . . . . . Motor Case Drain 0.217"  
(5,5 mm) Diameter
- ⑩ HYDROSTATIC MOTOR
- ⑪ HYDRAULIC PUMP, . . . Gear Type-Rated  
@ 2700 RPM
  - a. Hydraulic Pump, 16.2 GPM (61,3 L/min.)
  - b. Charge Pump, 10.8 GPM (40,9 L/min.)
  - c. Auxiliary Hydraulic Pump,  
6.9 GPM (26,1 L/min.)
- ⑫ PRESSURE SWITCH (Dual Function),  
Hourmeter Starts @ 19-23 PSI  
(131-159 kPa); Warning Light Turns  
Off @ 17-21 PSI (117-145 kPa)
- ⑬ RELIEF VALVE, 3000 PSI (20685 kPa)
- ⑭ HIGH PRESSURE RELIEF/REPLENISHING  
VALVES (4), . . . 3500 PSI (24133 kPa)
- ⑮ HYDROSTATIC PUMPS
- ⑯ AUXILIARY COUPLER, . . . . . Case Drain
- ⑰ AUXILIARY QUICK COUPLERS
- ⑱ AUXILIARY COUPLERS, . . . . . High  
Horsepower Flow
- ⑲ TILT CYLINDER
- ⑳ LIFT CYLINDERS
- ㉑ STEERING SERVO CONTROL
- ㉒ HYDRAULIC CONTROL VALVE
- ㉓ ORIFICE, . . . . . 0.024" (0,61 mm) Dia.
- ㉔ SOLENOID VALVE, . . . High Horsepower
  - a. Forward Flow Fluid Control (High Flow)
  - b. Reverse Flow Fluid Control (Low Flow)
- ㉕ ANTI-CAVITATION VALVE
- ㉖ LOADER CHECK VALVES, . . . . . 3
- ㉗ ORIFICE
- ㉘ MAIN RELIEF VALVE, (Electrical Controlled)  
Normal Operation;  
2200-2300 PSI (15159-15859 kPa)  
High Flow Control;  
3000 PSI (20685 kPa)
- ㉙ PORT RELIEF VALVE, . . . . . 3500 PSI  
(24133 kPa)
- ㉚ ELECTRICAL SELECTOR VALVE
- ㉛ UN-LOADING SPOOL/PRESS. RELIEF  
VALVE
- ㉜ FLOW CONTROL SPOOL
- ㉝ FLOW ADJUSTMENT VALVE
- ㉞ CHECK VALVE
- ㉟ BUCKET POSITION VALVE
- ㊱ FILTER, . . . . . Hydraulic #4 Element
- ㊲ BY-PASS VALVE, . . . . . 72 PSI (496 kPa)
- ㊳ OIL COOLER
- ㊴ FILTER, . . . . . Hydrostatic #3 Element
- ㊵ DIAGNOSTIC COUPLER
- ㊶ PRESSURE SWITCH, . . . . . Differential  
40 PSI (276 kPa)
- ㊷ BY-PASS VALVE, . . . . . 50 PSI (345 kPa)

## WIRE LEGEND

NO.'s	COLOR	GAUGE
12GA	Orange/White	16
50R	Black	16
50RA	Black	16
50S	Black	16
50V	Black	16
50W	Black	16
54E	Dk. Green	16
54EA	Dk. Green	16
54EB	Lt. Green/Yellow	16
54F	Dk. Green	16
54G	Dk. Green	16

## CHECKING & ADJUSTING MAIN RELIEF VALVE (DUAL PRESSURE)

1. Lift & block the loader.
2. Connect the hydraulic tester to the quick couplers **17**.
3. Disconnect the electrical connectors **3**<sup>a</sup> and **3**<sup>b</sup>.
4. Start the engine. Check the main relief valve **28** pressure.
5. Engage the high flow hydraulic system **2**.

**NOTE:** If the high pressure relief setting is adjusted, it will effect the standard relief pressure. Always adjust the high pressure setting first.

6. If adjustment is needed, loosen the jam nut and adjust the high flow relief valve pressure by turning in to increase pressure or out to decrease pressure. The correct setting is 2950-3050 PSI (20340-21030 kPa).
7. Disengage the high flow hydraulics. Stop the engine. Tighten the jam nut to 35 ft.-lbs. (47 Nm) torque.
8. Remove the access plug or loosen the jam nut on the main relief valve **28**.
9. Start the engine. Use an allen wrench and turn the screw in to increase or out to decrease pressure. The correct setting is 2150-2250 PSI (14824-15514 kPa).

## PARTS LEGEND

- 1** Harness Connector
- 2** Switch
- 3** Solenoid Connectors
  - a. Forward Fluid Flow
  - b. Reverse Fluid Flow
- 4** Ground

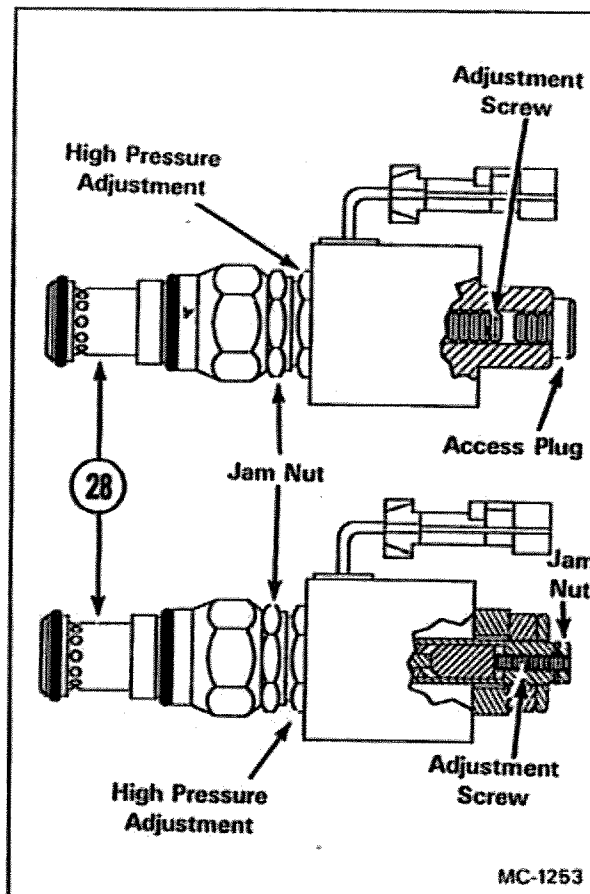

10. Stop the engine. Install the access plug or tighten the jam nut. Disconnect the hydraulic tester.
11. To check the relief valve **13** in the hydraulic pump end section: connect the hydraulic tester into the outlet of the pump **11** <sup>c</sup>. By restricting the flow, with the hydraulic tester, the pressure should be 3000 PSI (20685 kPa) at the relief valve **13**.

## FLUID FLOW EXPLANATION

Hydraulic fluid flows from the reservoir ① and enters the inlet port of the triple (3 section) gear pump ⑪ . The larger section ⑪ <sup>a</sup> of the pump supplies flow to the inlet of the hydraulic control valve ⑫ . The pump pressure is controlled by the main relief valve ⑬ . The control valve ⑫ is a four-section, open center, closed port, series type valve. When all four spools are in neutral position, the fluid goes through the control valve ⑫ and to the hydraulic filter ⑭ .

When the lift arms are raised, the hydraulic pump ⑪ <sup>a</sup> fluid flow is directed to the base end of the lift cylinders ⑮ . The fluid from the rod end of the lift cylinders ⑮ returns to the bucket position valve ⑯ and is directed to the center of the flow-control spool ⑰ . The flow-control spool ⑰ and flow adjustment valve ⑱ direct this flow. A percentage of the fluid is directed over the flow adjustment valve ⑱ to position the bucket. The rest of the fluid is directed through the orifice in the flow-control spool ⑰ and onto the return port of the control valve ⑫ (lift section).

The fluid flow from the flow-control spool ⑰ and flow adjustment valve ⑱ are against the un-loading spool/pressure relief valve ⑲ . The un-loading spool/pressure relief valve ⑲ moves to allow extension of the tilt cylinder ⑳ as the lift cylinders ⑮ raise the lift arms.

The un-loading spool/pressure relief valve ⑲ is to relief fluid from the base end of the tilt cylinder ⑳ if the bucket is fully rolled out and the lift cylinders ⑮ are still extending.

The fluid from the charge pump ⑪ <sup>b</sup> flows to the four-way cross fitting and is called "charge pressure fluid". The fluid flows to the oil cooler ㉓ or oil cooler by-pass valve ⑥ . The oil cooler by-pass valve ⑥ will open when the fluid temperature is cold or if there is excessive fluid pressure. The fluid flows through the oil cooler ㉓, then through the hydrostatic filter ④ and past the pressure switch ⑫ to supply the front and rear hydrostatic pump ⑮ with charge pressure and on to the charge by-pass valve ⑥ . The pressure switch ⑫ has a dual function, it starts the hourmeter and turns the warning light off. The charge pressure fluid flows into each pump ⑮ and motor ⑩ to cool, lubricate and replenish the fluid supply which has been lost through case drain. Also fluid from the four-way cross fitting supplies fluid to actuate the steering servo controls ㉑ and the electrical solenoids ㉒ for high horsepower operation. The return fluid from the steering servo controls ㉑ and electrical solenoids ㉒ flows to the port block ⑦ .

There are two hydrostatic pumps ⑮ and two hydrostatic motors ⑩ . One pump and one motor work together as a pair to drive one side of the loader. The other pump and motor work as a pair to drive the opposite side of the loader.

The swash plates of the hydrostatic pumps ⑮ are angled by the steering servo controls ㉑ in either direction, the pumps ⑮ force fluid, under pressure, to the motors ⑩ . The motors ⑩ turn and push the low pressure fluid back to the pumps ⑮ to be used again. The motors ⑩ contain a shuttle valve which allows some fluid from the drive loop to go to the port block ⑦ and back to the reservoir ① . The hydrostatic pumps ⑮ contain four high pressure relief/replenishing valves ⑭ . There are two valves ⑭ for drive on each side of the loader: one for forward travel and one for reverse travel. The high pressure relief/replenishing valves ⑭ have a dual function. The valve cartridges ⑭ are pushed off their seats to allow fluid flow from the charge loop to cool, lubricate and replenish the

pumps 15 and motors 10 . In forward or reverse (when the swash plates are angled), the fluid has a higher pressure the charge fluid. This pressure difference forces the high pressure replenishing valve 14 onto the seat. The high pressure replenishing valve 14 will open allowing the drive pressure to relieve into the charge loop to be used again if excessive pressure is generated by the pumps 15 .

Excess charge pressure fluid which is relieved over the charge by-pass valve 8 goes through the port block 7 and joins the hydrostatic motors 10 case drain and flows to the reservoir through the diffuser 4 . Fluid from the cold oil by-pass valve 6 flows into the port block 7 and back to the reservoir 1 under conditions of cold fluid or excess flow.

The hydraulic filter 36 has a by-pass valve 37 to protect the system if the filter element becomes plugged. The hydrostatic filter 39 has a by-pass valve 42 to protect the system if the filter element becomes plugged and a pressure differential switch 41 which indicates the condition of the filter element.

The diagnostic coupler 40 provides a quick access for checking the charge pressure in the system.

## HIGH FLOW OPERATION

Turning the switch 2 "ON" for high flow operation will activate the following functions: it will energize the electrical solenoid 24 a, the main relief valve 28 and the electrical selector valve 30 . When the electrical solenoid 24 a is energized the charge pressure will shift the control valve spool 22 to allow the fluid flow from the hydraulic pump 11 a to flow to the electrical selector valve 30 where the fluid joins with the fluid from the auxiliary hydraulic pump 11 c. This fluid then flows to the high flow quick coupler 18 at the front of the loader. The return fluid flows to the control valve 22 and to the hydraulic filter 37 . Case drain fluid (Example: Planer) will return through the coupler 16 and back to the port block 7 to join the fluid going to the reservoir 1 .

When the high flow operation is engaged; it also energized the main relief valve 28 which will increase the relief pressure to 3000 PSI (20685 kPa). The relief valve 13 in the auxiliary hydraulic pump 11 c and main relief valve 28 will open to relieve excessive pressure.

The fluid from the auxiliary hydraulic pump 11 c when not in use, flows to the electrical selector valve 30 and returns to the hydraulic filter 37 .

Turning the switch 2 "REV" for reverse operation will active the electrical solenoid 24 b and shift the control valve spool 22 to allow fluid flow from the hydraulic pump 11 a to flow to the high flow coupler 17 . The return fluid goes to the control valve 22 and to the hydraulic filter 37 . The electrical selector valve 30 and the main relief valve 28 are not energized in this function.

# HYDRAULIC / HYDROSTATIC FLOW CHART

For Model

## 843B

Chart #6720555 (Printed September 1992)

- RED - High Pressure
- BLUE - Low Pressure
- GREEN - Case Drain & Reservoir
- ORANGE - Charge Pressure
- LT. ORANGE - Bucket Position Fluid Flow

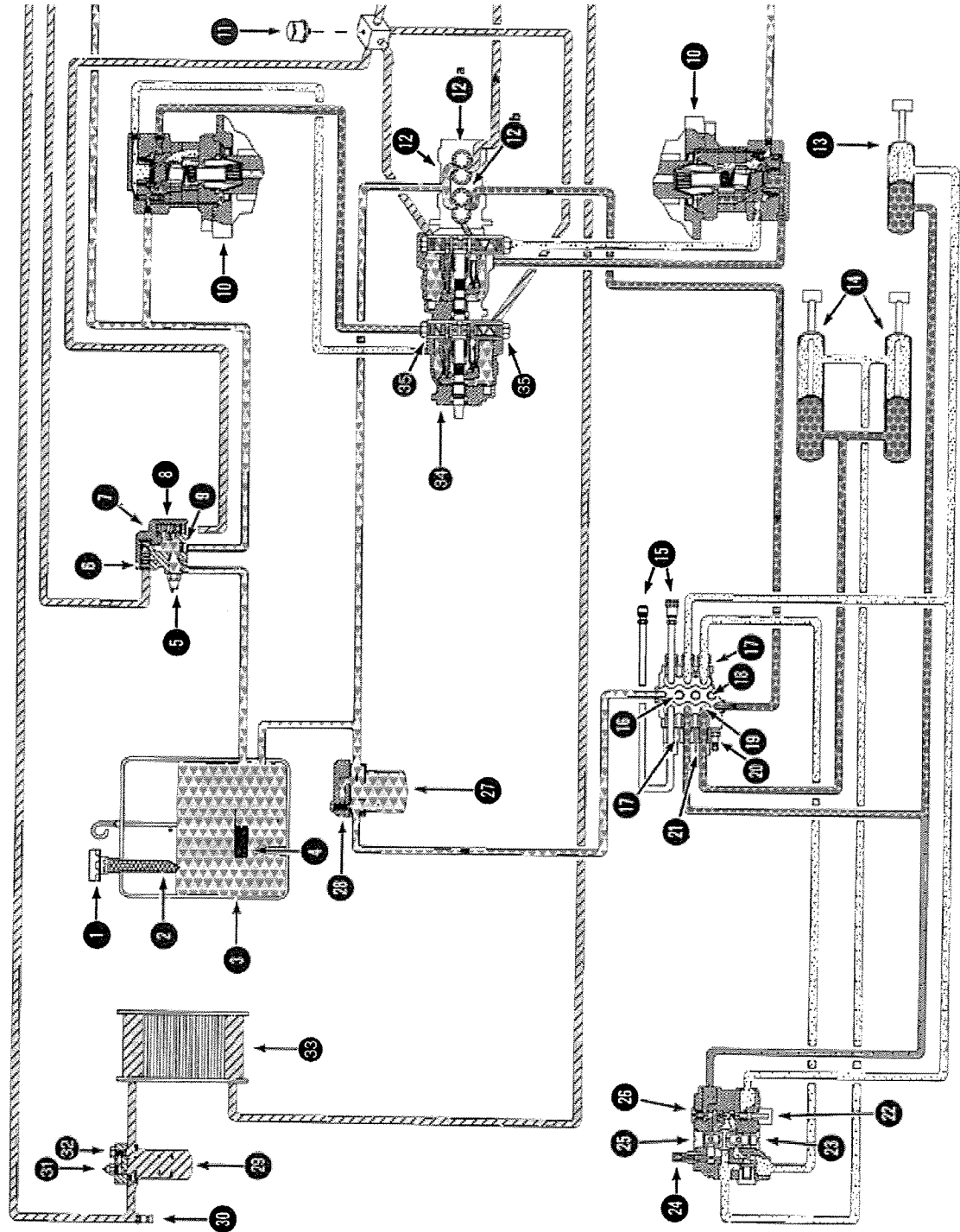

**NOTE**  
 Chart shows oil flow in Forward Drive Position and with Hydraulic Cylinders Partially Extended. For Hydraulic/Hydrostatic System Operation, refer to Sheet 2 of this publication.

Printed in U.S.A.

(Sheet 1 of 2)

6720555 (9-92)



# HYDRAULIC / HYDROSTATIC SYSTEM OPERATION

## To Be Used With HYDRAULIC / HYDROSTATIC FLOW CHART

For Model  
**843B**

Chart #6720555 (Printed September 1992)

### CHART LEGEND

- |  |  |
|--|--|
| ① BREATHER CAP, . . . . . 5 Micron   | ②③ FLOW CONTROL SPOOL  |
| ② SCREEN, . . . . . 100 Mesh   | ②④ FLOW ADJUSTMENT VALVE   |
| ③ RESERVOIR, Capacity<br>3.5-4.0 Gals. (13,2-15,1 L.)  | ②⑤ CHECK VALVE   |
| ④ DEFUSER  | ②⑥ BUCKET POSITION VALVE (OPT.)  |
| ⑤ TEMPERATURE SWITCH, 225-232° F.<br>(108-111° C.)   | ②⑦ HYDRAULIC FILTER, . . . . . 10 Micron                                       |
| ⑥ COLD FLUID BY-PASS VALVE,<br>297 PSI (2048 kPa)  | ②⑧ BY-PASS VALVE, . . 72 PSI (496 kPa)   |
| ⑦ PORT BLOCK   | ②⑨ HYDROSTATIC FILTER, . . #3 Element  |
| ⑧ CHARGE BY-PASS VALVE,<br>110 PSI (758 kPa)   | ③⑩ DIAGNOSTIC COUPLER  |
| ⑨ ORIFICE, . . . . . Motor Case Drain<br>0.217" (5,5 mm)   | ③① DIFFERENTIAL PRESSURE SWITCH,<br>40 PSI (276 kPa)                           |
| ⑩ HYDROSTATIC MOTOR  | ③② BY-PASS VALVE, . . 50 PSI (345 kPa)   |
| ⑪ PRESSURE SWITCH (Dual Function)<br>Hourmeter Starts @ 19-23 PSI (131-159<br>kPa); Warning Light Turns Off @ 17-21<br>PSI (117-145 kPa)                                   | ③③ OIL COOLER  |
| ⑫ HYDRAULIC PUMP, . . . . . Gear Type<br>Rated @ 2700 RPM &<br>1050 PSI (7239 kPa)<br>a. Charge Pump, 11.5 GPM (43,5 L/min.)<br>b. Hydraulic Pump, 16.1 GPM (60,9) L/min.) | ③④ HYDROSTATIC PUMPS   |
| ⑬ TILT CYLINDER  | ③⑤ HIGH PRESSURE/REPLENISHING RELIEF<br>VALVES, . . . . . 3500 PSI (24133 kPa) |
| ⑭ LIFT CYLINDERS   |  |
| ⑮ AUXILIARY QUICK COUPLERS (OPT.)  |  |
| ⑯ LOAD CHECK VALVES (3)  |  |
| ⑰ ANTI-CAVITATION VALVE  |  |
| ⑱ HYDRAULIC CONTROL VALVE  |  |
| ⑲ ORIFICE  |  |
| ⑳ MAIN RELIEF VALVE,<br>2250-2400 PSI (15514-16558 kPa)  |  |
| ㉑ PORT RELIEF VALVE,<br>3500 PSI (24133 kPa)   |  |
| ㉒ UN-LOADING SPOOL/PRESSURE<br>RELIEF VALVE  |  |

## FLUID FLOW EXPLANATION

Hydraulic fluid flows from the reservoir ③ to the inlet port of the tandem (2 section) gear pump ⑫. The larger section ⑫<sup>b</sup> of the hydraulic pump supplies pressure to the inlet of the hydraulic control valve ⑮. The pump pressure is controlled by the main relief valve ⑳. The control valve ⑮ is a three-section, open center, closed port, series type valve. When all three spools are in neutral position, the fluid goes through the control valve ⑮ to the hydraulic filter ㉓.

If one of the spools is activated, the fluid goes out the respective port to either the base end, or the rod end of the cylinder(s) ⑬ ⑭. As the fluid goes into one end of the cylinder(s) ⑬ ⑭ the fluid from the other side of the cylinder flows back into the control valve ⑮. **ALSO SEE BUCKET POSITIONING SYSTEM OPERATION (OPTIONAL).**

When the cylinder(s) ⑬ ⑭ reach the end of the stroke, the fluid reaches the setting of the main relief valve ⑳, it will open and let the fluid by-pass the hydraulic circuit (internally) and go back to the reservoir ③.

The fluid flows from the charge pump ⑫<sup>a</sup> to either the oil cooler ㉔ or the cooler by-pass valve ⑥ which will open when there is cold fluid or if there is excessive fluid pressure. The fluid flows through the oil cooler ㉔, then through the hydrostatic filter ㉕ and into the four-way block. The fluid flows past the pressure switch ⑪ to the charge by-pass valve ⑧. The pressure switch ⑪ has a dual function, it starts the hourmeter and turns the warning light "OFF".

Normal flow of fluid is through the four-way block to the front and rear hydrostatic pumps ㉖. This fluid flow is called "charge pressure" and supplies the hydrostatic pumps ㉖ and hydrostatic motors ⑩ with charge fluid. The charge fluid is used by the pumps and motors, but as the charge pressure increases, the charge by-pass valve ⑧ will open to prevent excessive pressure build-up.

The charge fluid flows into each pump ㉖ and motor ⑩ to cool, lubricate and replenish the fluid supply which is lost through case drain. Case drain from the pumps ㉖ flows into the inlet side of the hydraulic pump ⑫ through internal porting.

There are two hydrostatic pumps ㉖ and motors ⑩. One pump and one motor work together as a pair to drive one side of the loader. The other pump and motor work as a pair to drive the opposite side of the loader.

The swashplates of the hydrostatic pumps ㉖ are angled to either direction, the pumps ㉖ force fluid, under pressure, to the motors ⑩. The motors ⑩ turn and push the low pressure fluid back to the pumps ㉖ to be used again. The motors ⑩ contain a shuttle valve which allows some fluid from the "drive loop" to go to the port block ⑦ and back to the reservoir ③.

The hydrostatic pumps 34 contain four high pressure relief/replenishing valves 35. There are two valves 35 for drive on each side of the loader: one for forward travel and one for reverse travel. The high pressure relief/replenishing valves 35 have a dual function. In neutral the valve cartridges 35 are pushed off their seats to allow fluid flow from the charge loop to cool, lubricate and replenish the pumps 34 and motors 10. In forward or reverse travel, the fluid has a higher pressure than charge pressure fluid. This pressure difference forces one of the high pressure replenishing valves 35 against the seat. The high pressure replenishing valves 35 also act as a high pressure relief valve for the pumps 34. The high pressure replenishing valves 35 will open allowing the "drive pressure" to relieve into the charge loop to be used again if excessive pressure is generated by the pumps 35.

Excess charge pressure fluid which is relieved over the charge by-pass valve 8 goes through the port block 7 and joins the hydrostatic motors 10 case drain fluid and flows to the reservoir 3 through the defuser 4. Fluid from the cold fluid by-pass valve 6 flows into the port block 7 and back to the reservoir 3.

Both the hydraulic filter 27 and hydrostatic filter 29 have a by-pass 28 32. The hydrostatic filter 29 also has a pressure differential switch 31 which indicates the condition of the filter.

The diagnostic coupler 30 provides a quick access for checking the charge pressure.

#### BUCKET POSITIONING SYSTEM OPERATION (OPTIONAL)

The lift and tilt section of the control valve 18 work together to position the bucket as the lift arms are being raised. When the lift arms are being raised, the hydraulic pump 12<sup>b</sup> flow is directed to the base end of the lift cylinders 14. The fluid from the rod end of the lift cylinders 14 returns to the bucket position valve 26 and is directed to the center of the flow-control spool 23. The flow-control spool 23 has an orifice at each end. Some of the fluid flow is directed to the base end of the tilt cylinder 13 and the other portion of the fluid is directed through the opposite end of the flow-control spool 23 to the return port of the lift section of the control valve 18.

The fluid flow from the flow-control spool 23 is against the un-loading spool 22 and flow adjustment valve 24. An increase in fluid pressure causes the flow adjustment valve 24 to open which allows the flow of the fluid to the base end of the tilt cylinder 13. The fluid from the rod end of the tilt cylinder 13 is contained by the un-loading spool 22 and allows the rod end fluid to return into the control valve 18. The pressure relief valve 22 is to relief fluid from the base end of the tilt cylinder 13 if the bucket is fully rolled out and the lift cylinders 14 are still being extended.





## 2 HYDRAULIC SYSTEM

### TROUBLESHOOTING

The following troubleshooting chart is provided as an assistance in locating and correcting problems which are most common. Many of the recommended procedures must be done by authorized Bobcat Service Personnel only.

PROBLEM	CAUSE
The hydraulic system will not operate.	1, 2, 3, 4
Slow hydraulic system action.	1, 3, 5, 6, 7
Hydraulic action is not smooth.	1, 5, 6, 7, 8
Lift arms go up slowly at full engine RPM.	1, 3, 5, 6, 7, 9, 10, 11
The lift arms or Bob-Tach will move with the pedal in neutral position.	5, 10
The lift arms come down with the pedal in the neutral position.	5, 11, 12, 13, 14
The bucket does not self-level.	15, 16, 17
The bucket will partially self-level.	15, 16
The bucket has no power to roll forward.	17
The bucket does not roll back.	16

KEY TO CORRECT THE CAUSE
<ol style="list-style-type: none"> <li>1. The fluid level is not correct.</li> <li>2. The pedal linkage is disconnected.</li> <li>3. The hydraulic pump has a defect.</li> <li>4. The relief valve has a defect.</li> <li>5. The pedal linkage is not adjusted correctly.</li> <li>6. Relief valve is not at the correct pressure.</li> <li>7. Suction leak on the inlet side of the hydraulic pump.</li> <li>8. Fluid is cold.</li> <li>9. Using the loader for more than its rated capacity.</li> <li>10. Spool in the valve section is not centering or the centering spring is broken.</li> <li>11. Internal leak at the lift cylinder(s).</li> <li>12. External leak at the lift cylinder(s).</li> <li>13. Port relief seal is leaking.</li> <li>14. Load check has a defect in the valve section.</li> <li>15. Check the flow divider.</li> <li>16. Check the unloading spool.</li> <li>17. Check the self-level relief.</li> </ol>

## HYDRAULIC SYSTEM INFORMATION

# IMPORTANT

Always keep hydraulic and hydrostatic parts clean. Clean outside of all assemblies before beginning repairs. Use plugs and caps to cover open ports. Dirt can quickly damage the system.

I-2021-0284

### Flare Connections

Use the following procedure to tighten the flare fitting:

Tighten the nut until it makes contact with the seat.

Make a mark across the "flats" of both the male and female parts of the connection **A**.

Use the chart to find the correct tightness needed **B**.

If the fitting leaks after tightening, disconnect it and inspect the seat area for damage.

### Straight Thread O-ring Fitting

When installing this fitting, the O-ring must be first lubricated. Loosen the jam nut, install the fitting into place, then tighten the jam nut. Tighten the jam nut until it and the washer are tight against the surface **C**.

### Tubelines and Hoses

Make replacement of tubelines which are bent or have become flat. There will be a restriction of fluid flow, which will give a slow hydraulic action and cause heat.

Make replacement of hoses which show signs of wear, damage or weather cracked rubber.

When installing tubelines or hoses, make sure you use two wrenches when loosening and tighten them.

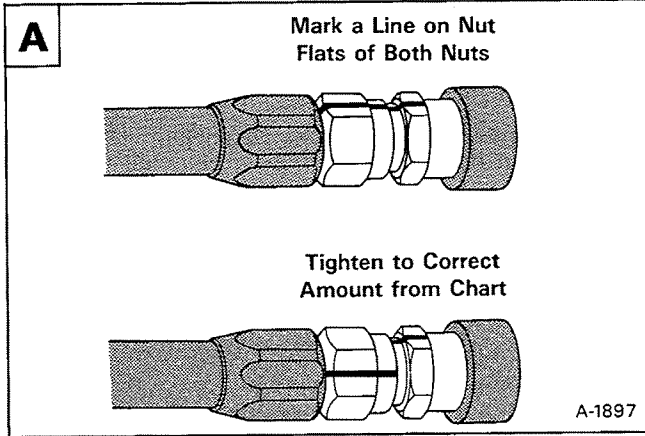

**B**

Wrench Size	Tube Size Outside Dia.	Thread Size	Rotate No. of Hex Flats
5/8"	5/16"	1/2" - 20	2-1/2
11/16"	3/8"	9/16" - 18	2
7/8"	1/2"	3/4" - 16	2
1"	5/8"	7/8" - 14	1-1/2 - 2
1-1/4"	3/4"	1-1/16" - 12	1
1-3/8"	1"	1-5/16" - 12	3/4 - 1
2"	1-1/4"	1-5/8" - 12	3/4 - 1
2-1/4"	1-1/2"	1-7/8" - 12	1/2 - 3/4

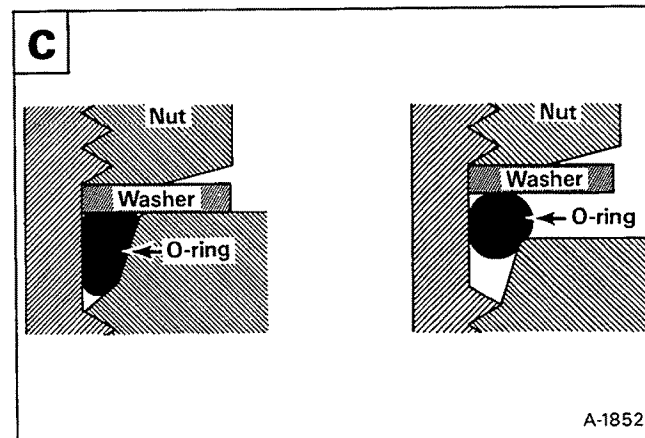

## LIFT CYLINDER

### Checking the Lift Cylinder(s)

Lower the lift arms. Stop the engine. Activate the lift pedal to release the hydraulic pressure.

Open the rear door.

Disconnect the hose from the tubeline which comes from the base end of the lift cylinder (right side) **A** (left side) **B**. Only check one cylinder at a time.

Put a plug in the tubeline.

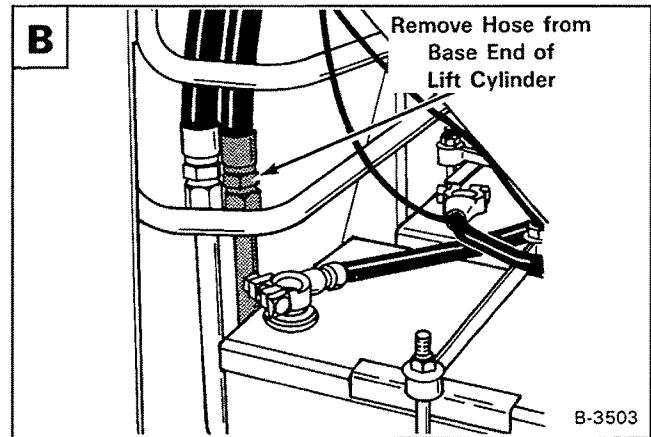
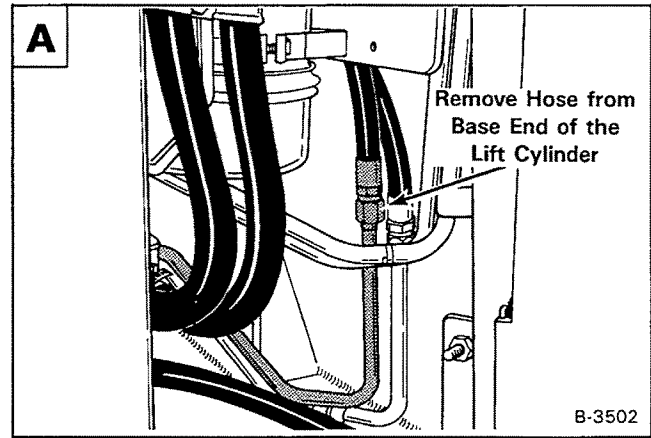

## WARNING

Diesel fuel or hydraulic fluid under pressure can penetrate skin or eyes causing serious injury. Fluid leaks under pressure may not be visible. Use a piece of cardboard or wood to find leaks. Do not use your bare hand. Wear safety goggles. If fluid enters skin or eyes, get immediate medical attention.

W-2074-1285

Start the engine and push the top (toe) of the lift pedal. If there is any leakage from the open hose, remove the cylinder for repair.

Repeat this procedure to check the lift cylinder on the other side.

### Removal and Installation

Raise the lift arms. Install jackstands under the Bob-Tach. Stop the engine. Activate the lift pedal to release the hydraulic pressure.

Remove the lock bolt at the rod end of the cylinder **C**.

Installation: Tighten the lock bolt to 8-10 ft.-lbs. (11-14 Nm) torque.

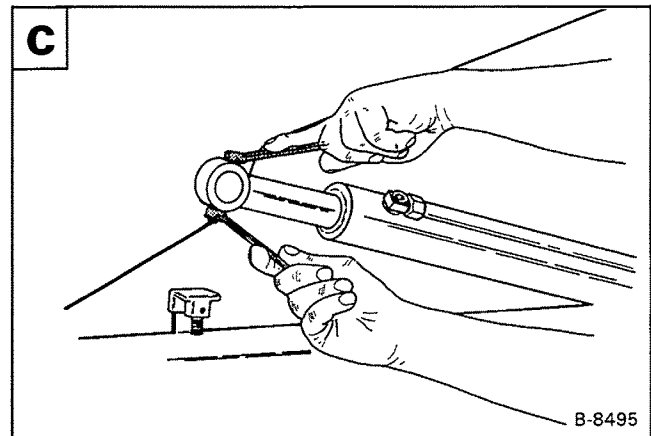

Remove the rod end pin **D**.

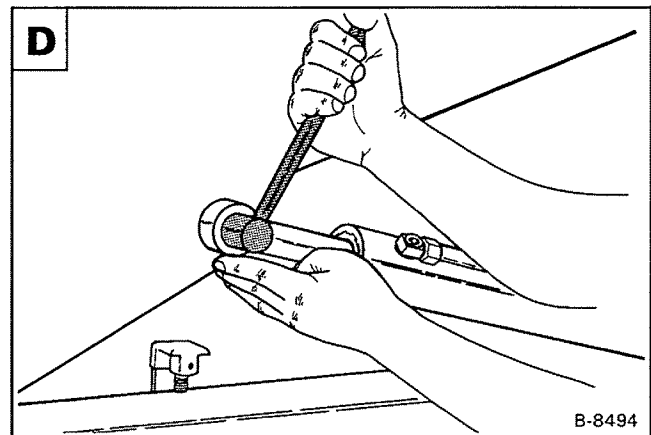

### LIFT CYLINDER (Cont'd)

Remove the lock bolt at the base end pivot pin.

Remove the base end pivot pin **A**.

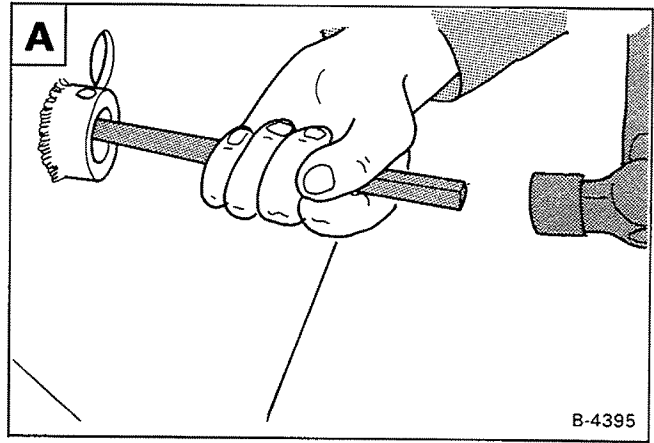

Slide the cylinder forward a small amount. Disconnect the hoses from the cylinder **B**.

Remove the lift cylinder from the loader.

See Page 2-13 for Hydraulic Cylinder Repair.

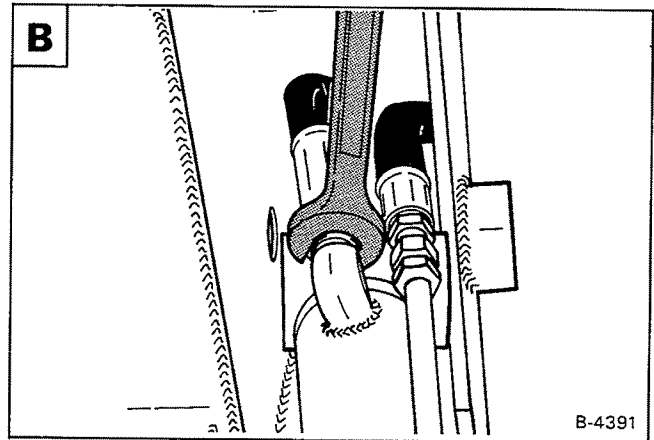

Copyright © 2008 Caterpillar Inc. All rights reserved. Printed in the U.S.A. 1Z-213-3 B/25/21008

## TILT CYLINDER

### Checking the Tilt Cylinder

Remove the bucket. Roll the Bob-Tach fully backward. Stop the engine. Activate the tilt pedal to release the hydraulic pressure.

Disconnect the hose which goes to the base end of the tilt cylinder **A**.

Put a plug in the hose.



## WARNING

Diesel fuel or hydraulic fluid under pressure can penetrate skin or eyes causing serious injury. Fluid leaks under pressure may not be visible. Use a piece of cardboard or wood to find leaks. Do not use your bare hand. Wear safety goggles. If fluid enters skin or eyes, get immediate medical attention.

W-2074-1285

Start the engine and push the bottom (heel) of the tilt pedal.

If there is leakage from the open port, remove the tilt cylinder for repair.

### Removal and Installation

Remove the bucket or attachment. Roll the Bob-Tach fully forward. Stop the engine. Push the tilt pedal to release the hydraulic pressure.

Disconnect the hoses at the tilt cylinder **B**.

Remove the lock bolt at the rod end pin **C**.

Installation: Tighten the lock bolt to 8-10 ft.-lbs. (11-14 Nm) torque.

Remove the rod end pin **D**.

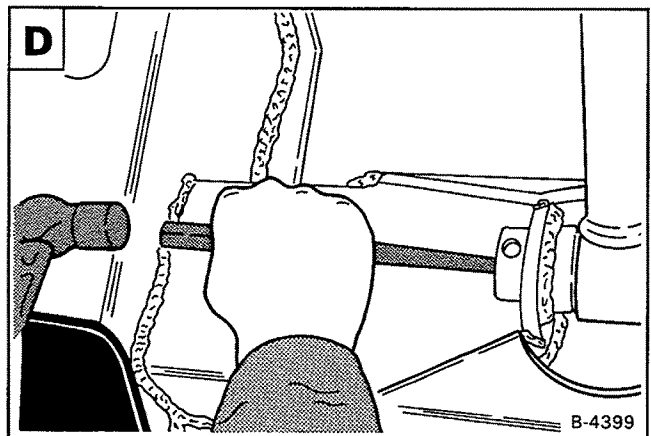
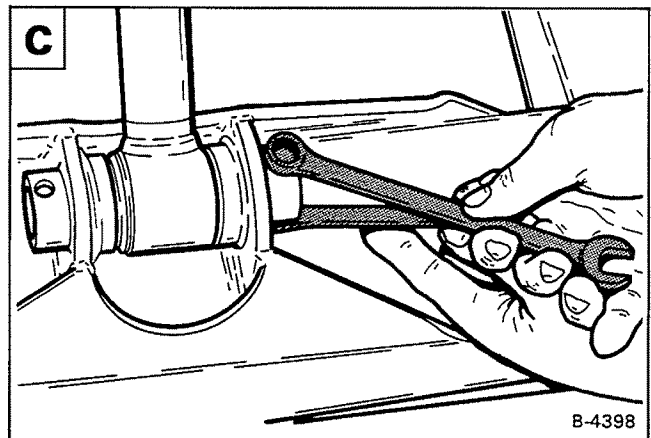
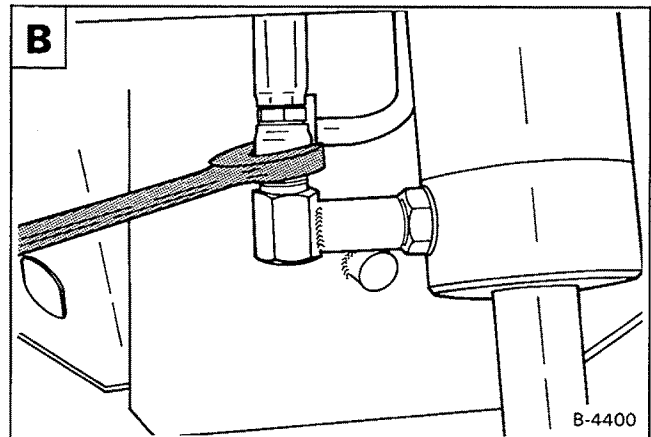
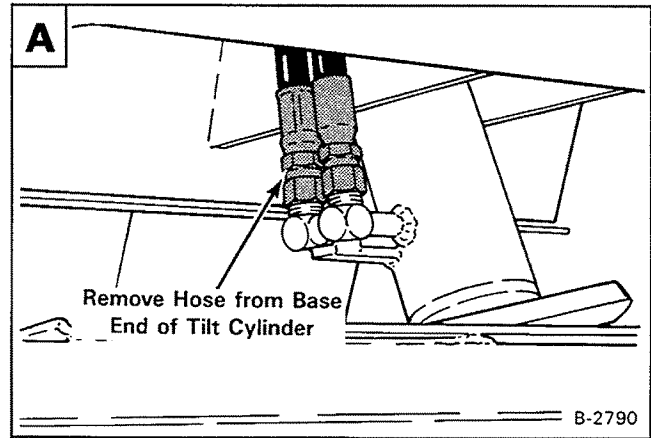

## TILT CYLINDER (Cont'd)

Remove the lock bolt at the base end pin **A**.

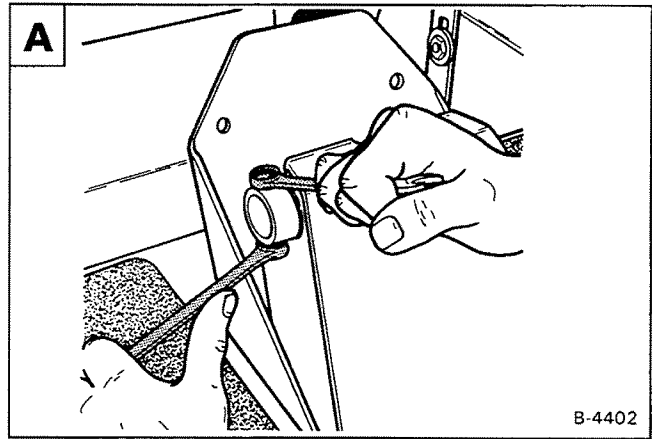

Remove the pin at the base end of the tilt cylinder **B**.

Remove the tilt cylinder from the loader.

See Page 2—7 for the Cessna tilt cylinder and Page 2—13 for all the other tilt cylinders.

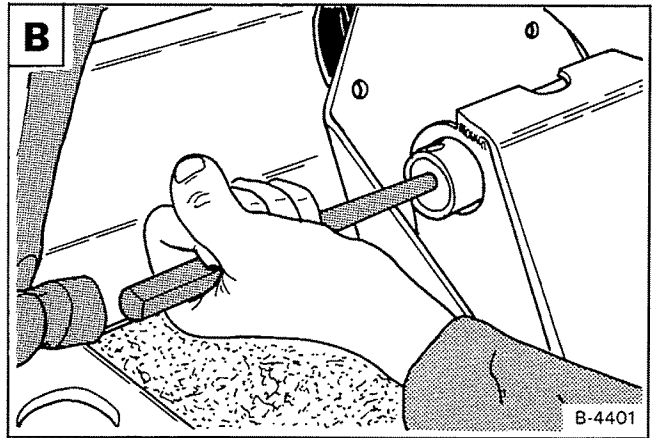

## Rod End Seal

Remove the old seal at the rod end of the cylinder. Install a new seal with the lip facing out **C**.

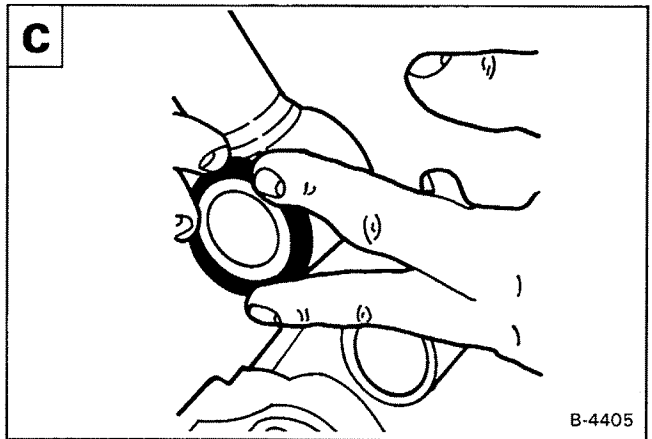

Use two pieces of shim stock, to install the rod end of the cylinder, so there is no damage to the seals **D**.

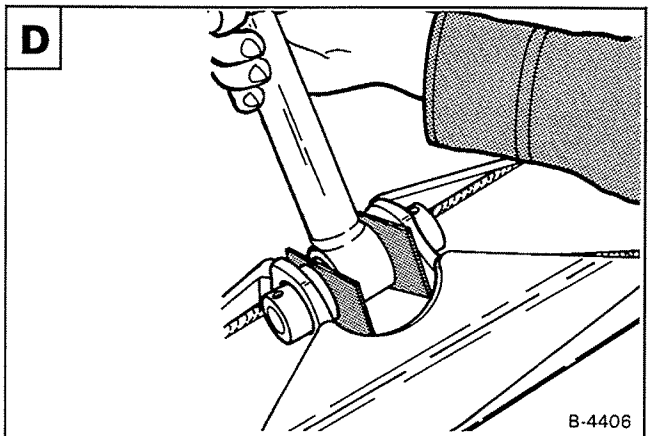

## TILT CYLINDER (CESSNA)

The tools listed will be needed to do the following procedure:

- MEL-1074 — O-ring Seal Hook
- MEL-1033 — Rod Seal Installation Tool
- MEL-1075 — Gland Nut Wrench
- MEL-1010 — Seal Installation Tool

### Disassembly

**NOTE:** If there is movement between the head and the snap ring the complete cylinder must be replaced.

Put the base end of the cylinder in a drain pan. Move the rod in and out to remove the fluid from the cylinder barrel.

Put the base end of the cylinder in a vise.

Put a cap on the fitting (Item 1) in the end cap **A**.

Lift the retainer ring (Item 2) out of the cylinder barrel **A**.

Put a wrench on the fitting and turn the end cap counterclockwise to remove the retainer ring **B**.

Remove the cylinder end cap, piston and rod assembly from the cylinder barrel **C**.

Put the rod end of the rod in a vise. Remove the piston from the rod **D**.

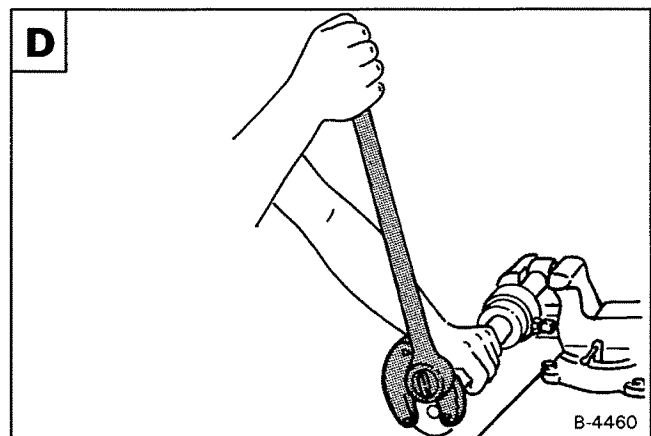
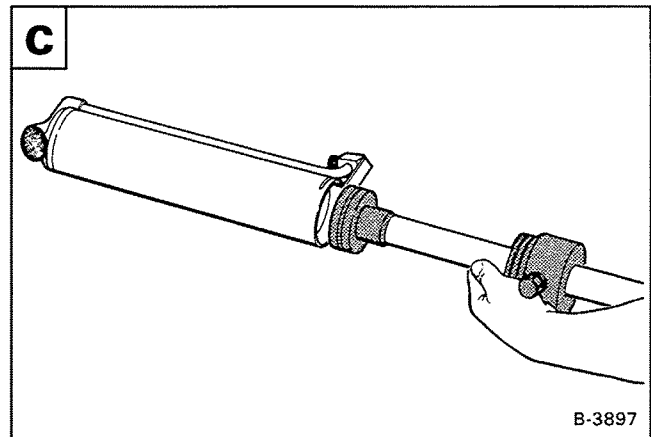
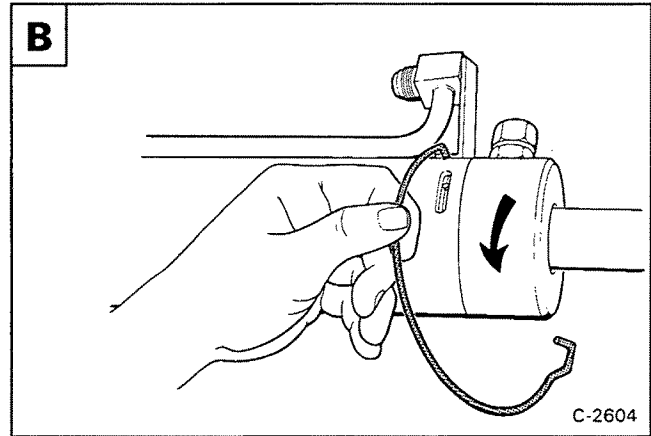
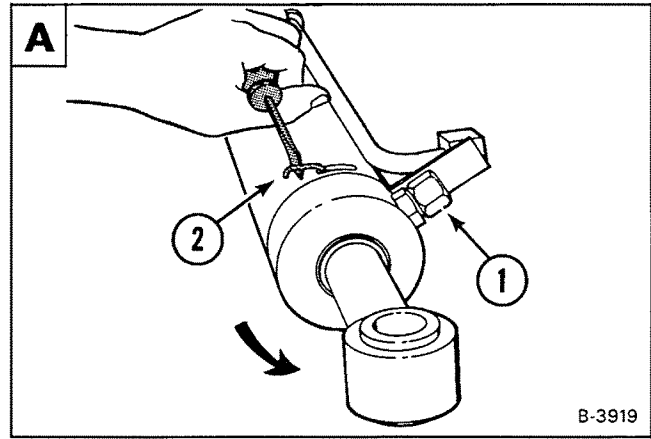



**TILT CYLINDER (CESSNA) (Cont'd)**

Remove the O-ring from the end of the rod **A**.

Remove the cushion sleeve from the rod **A**.

Remove the end cap from the rod.

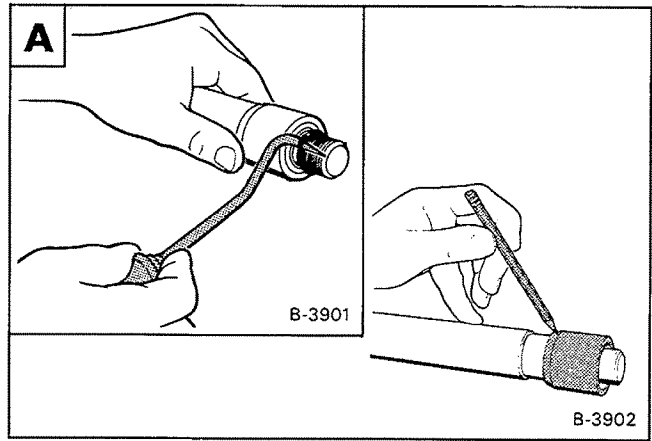

Remove the wiper seal **B**.

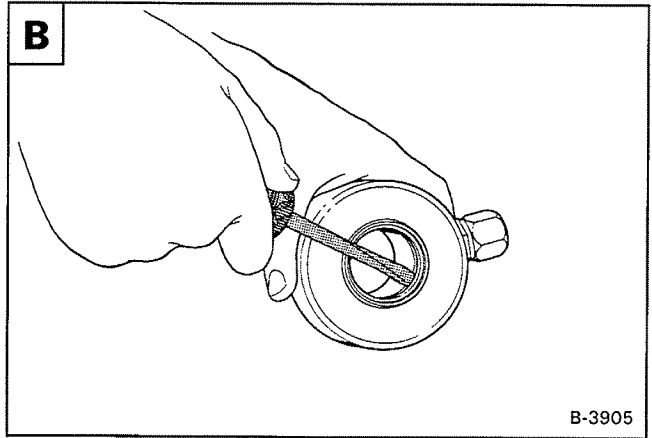

Remove the oil seal **C**.

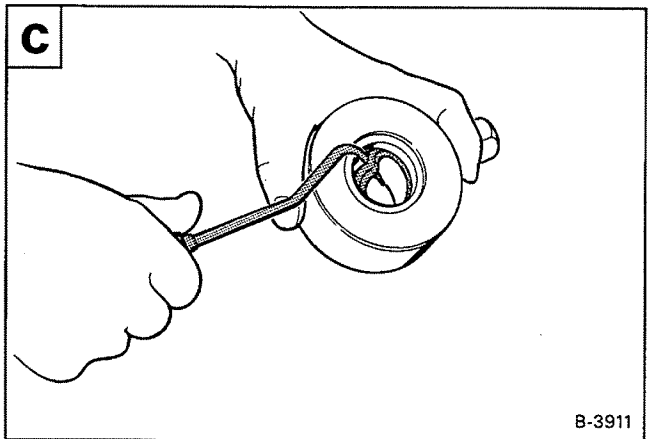

Remove the O-ring (Item 1) and back-up washer (Item 2) from the end cap **D**.

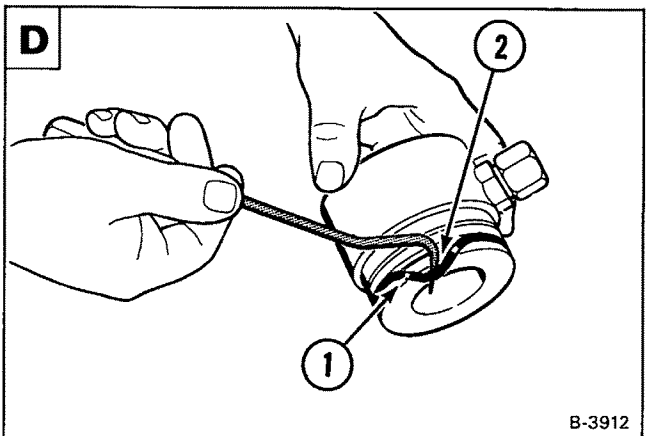

TILT CYLINDER (CESSNA) (Cont'd)

Assembly

Remove the teflon seal and the O-ring from the piston **A**.

Wash all the parts in clean solvent. Dry with air only. Destroy old seals and O-rings.

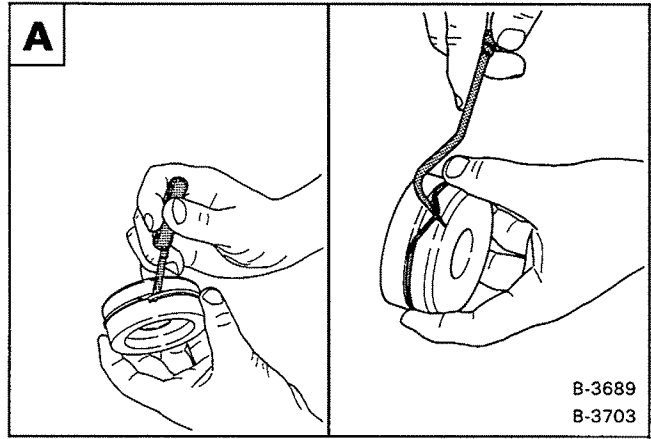

Install the piston on the tool **B**.

Install the O-ring on the piston using the tool **B**.

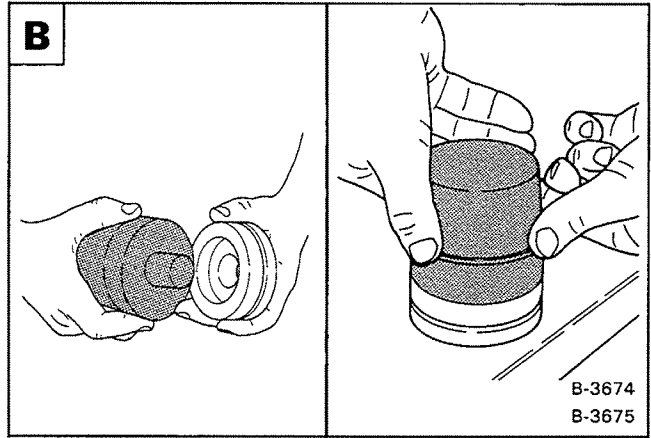

Install the teflon seal over the tool and on the piston **C**.

**NOTE:** To prevent damage to the teflon seal, do not turn it into the piston groove.

Install the piston into the tapered end of the tool to get the teflon seal to piston size diameter.

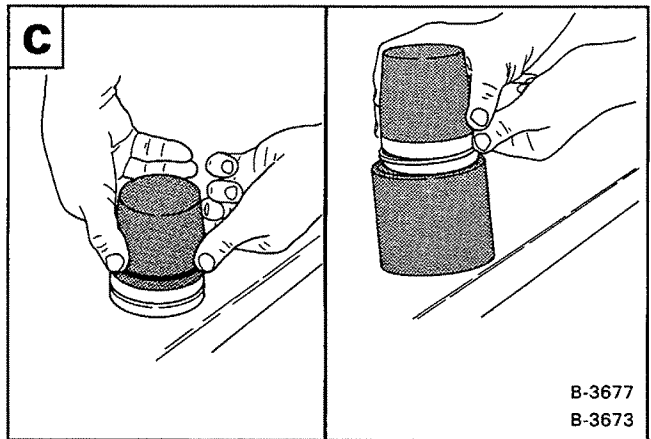

Install the oil seal in the end cap **D**.

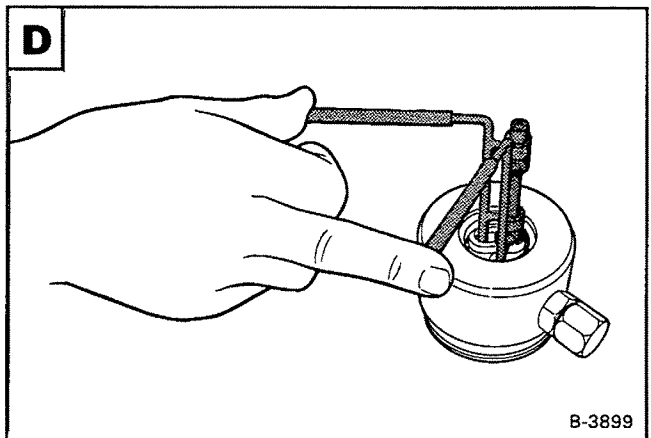

**TILT CYLINDER (CESSNA) (Cont'd)**

Install the wiper seal, with the lip toward the outside of the end cap **A**.

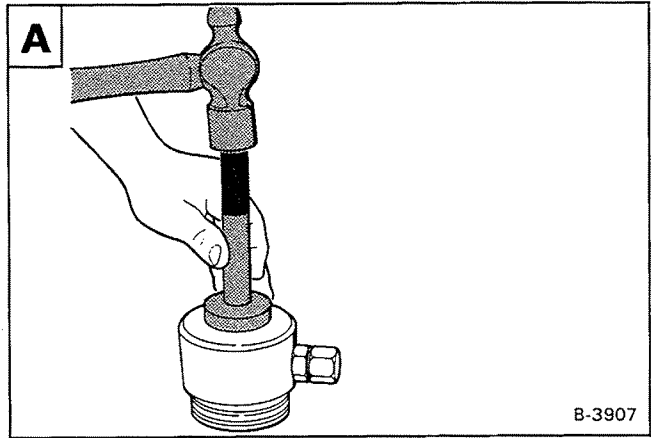

Install the back-up washer (Item 1) and O-ring (Item 2) on the end cap **B**.

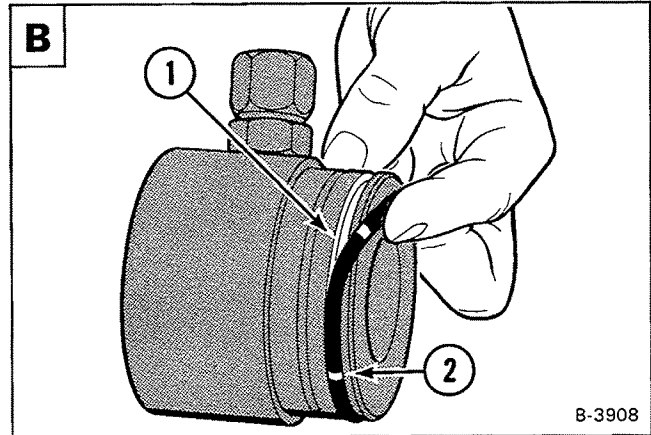

Put oil on the oil and wiper seal and install on the rod **C**.

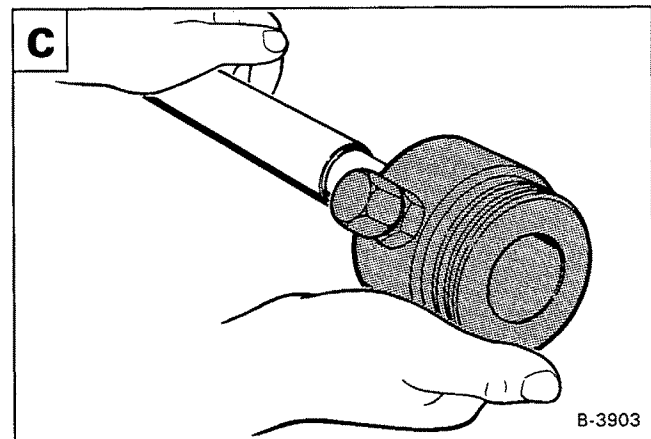

Install the cushion sleeve, with tapered end toward the end cap **D**.

Install the O-ring on the end of the rod.

Remove the piston from the tool.

Install the piston on the shaft, with the recessed edge toward the O-ring **D**.

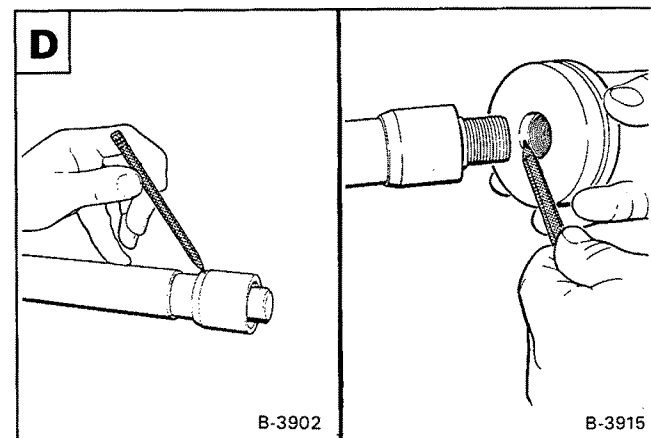

11/20/08 11:50:08 AM 4/1/2008 11:50:08 AM - EXPIRES 08/24/2008

**TILT CYLINDER (CESSNA) (Cont'd)**

Tighten the piston to 400-455 ft.-lbs. (542-617 Nm) torque **A**.

Lubricate the teflon seal and O-ring.

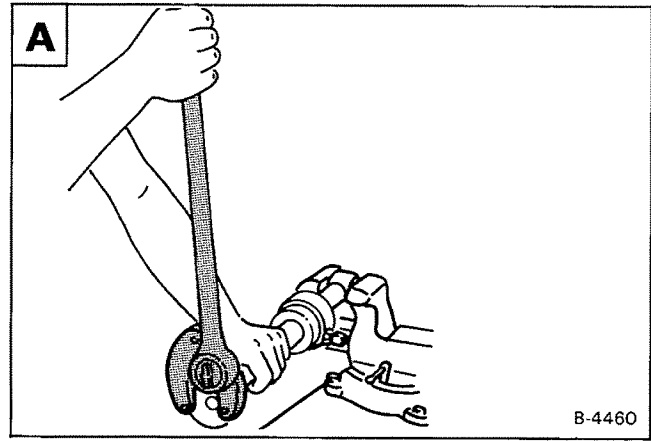

Install the piston into the cylinder barrel and work the teflon seal and O-ring past the slot in the barrel **B**.

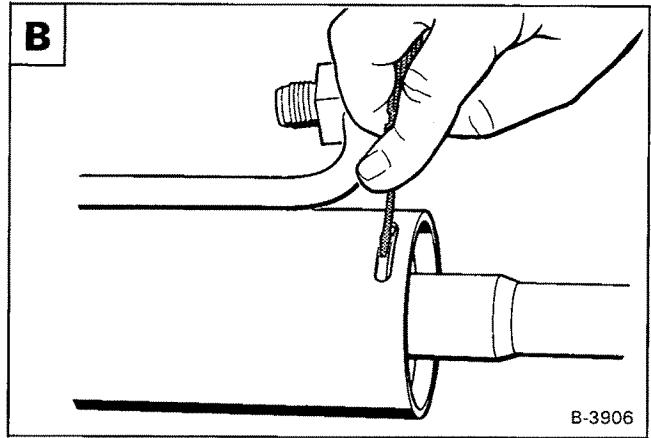

Install the rod and end cap assembly into the cylinder barrel **C**.

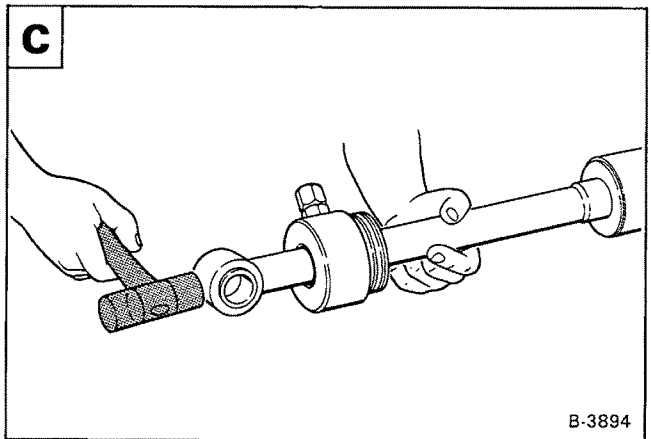

Install the end cap into the barrel, work the O-ring past the slot **D**.

Rotate the end cap until the small hole in the end cap can be seen in the slot.

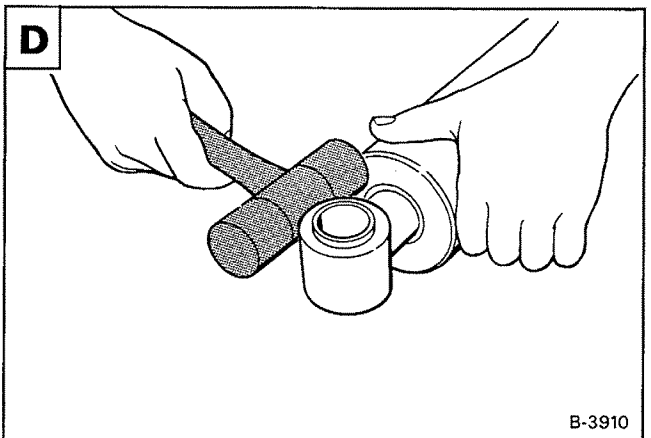

### TILT CYLINDER (CESSNA) (Cont'd)

Install the new retainer ring hook end (Item 1) into the hole in the end cap **A**.

Turn the end cap clockwise until the retainer ring is in the slot.

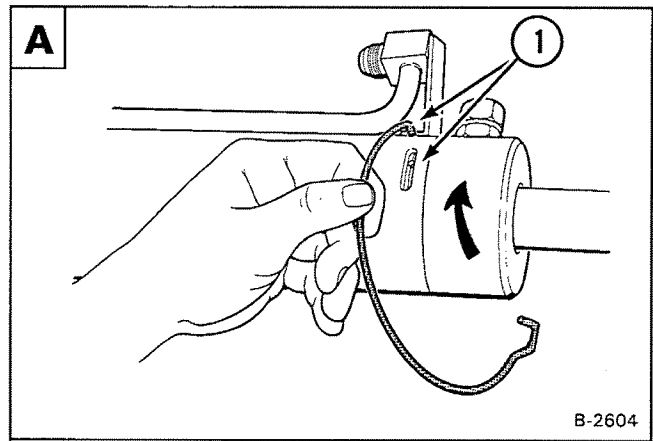

Push down on the retainer ring and make sure it is seated correctly **B**.

Push the cylinder rod in and out the full length. It must travel freely through the full stroke.

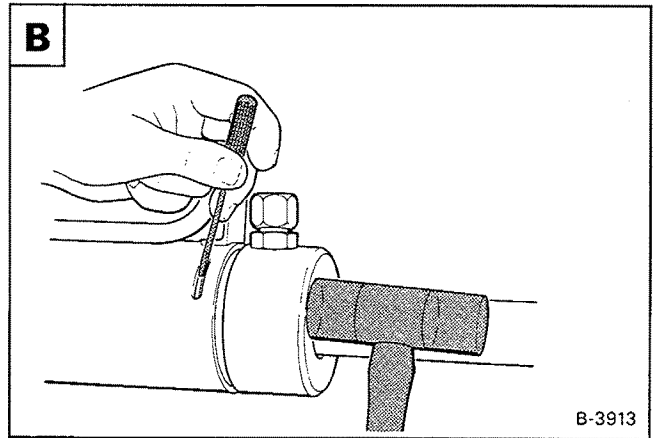

Page 61 - Bushnell 40451001 - 4/25/09 4:12:10 PM - PRINTED BY KEN COOK CO. - GRAPHIC.EKE (V2.4).3 8/25/2009

## HYDRAULIC CYLINDER REPAIR

**NOTE:** The following procedure can be used for the lift and tilt cylinders.

### Disassembly

The tools listed will be needed to do the following procedure:

- MEL-1074 — O-ring Seal Hook
- MEL-1033 — Rod Seal Installation Tool
- MEL-1075 — Gland Nut Wrench
- MEL-1215 — Seal Installation Tool
- MEL-1178 — Seal Installation Tool

Put the base end of the cylinder in a drain pan. Move the rod in and out to remove the fluid from the cylinder barrel.

Put the base end of the cylinder in a vise. Remove the end cap from the cylinder using the special tool **A**.

Remove the rod with the end cap and piston from the cylinder barrel.

Put the rod end of the shaft in the vise and remove the nut **B**.

Remove the piston from the rod **C**.

Remove the end cap from the rod **D**.

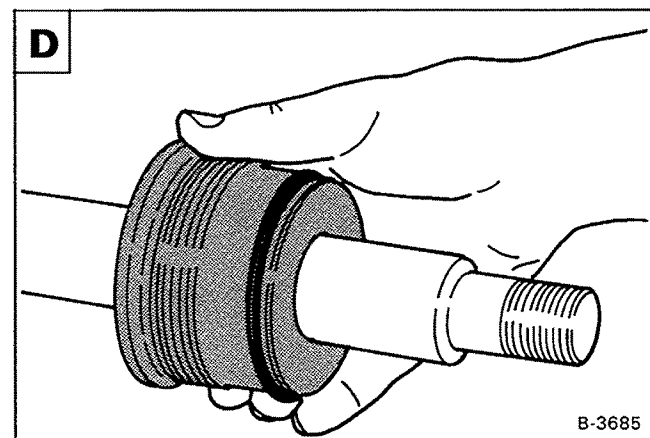
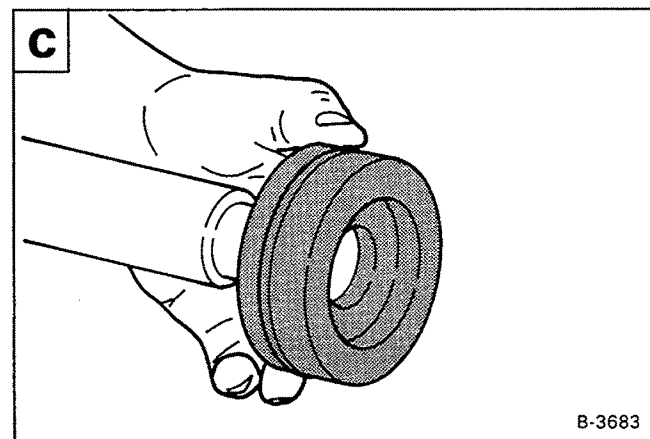
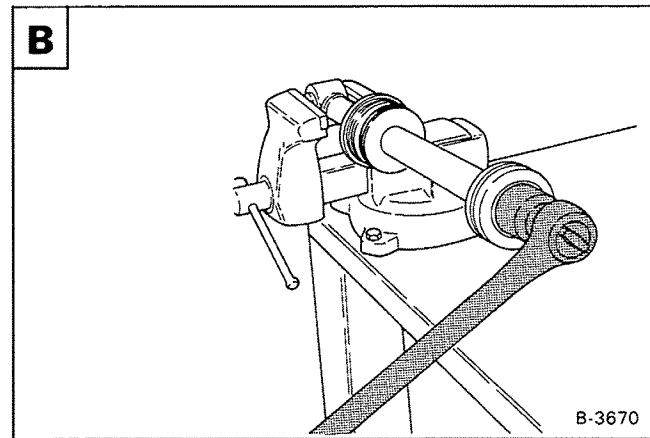
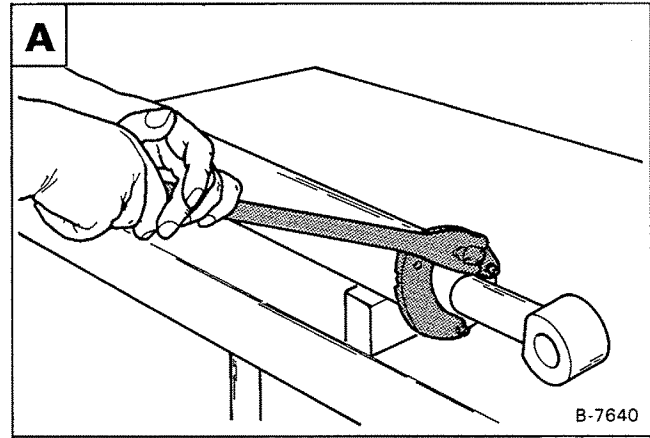



## HYDRAULIC CYLINDER REPAIR (Cont'd)

### Assembly

Inspect the parts for scratches, nicks, bent, etc. Replace the parts as needed.

Install the piston on the tool **A**.

Install the O-ring on the piston using the tool **A**.

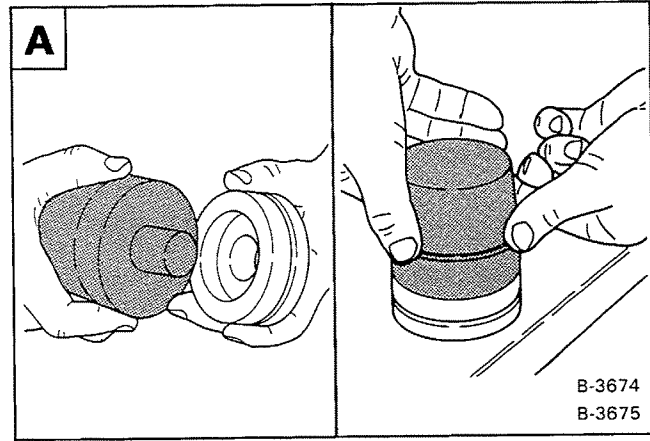

Install the teflon seal over the tool and on the piston **B**.

**NOTE:** To prevent damage to the teflon seal, do not turn it into the piston groove.

Install the piston into the tapered end of the tool to get the teflon seal to the piston size diameter.

Wait 5 minutes so that the teflon seal becomes the same size as the piston.

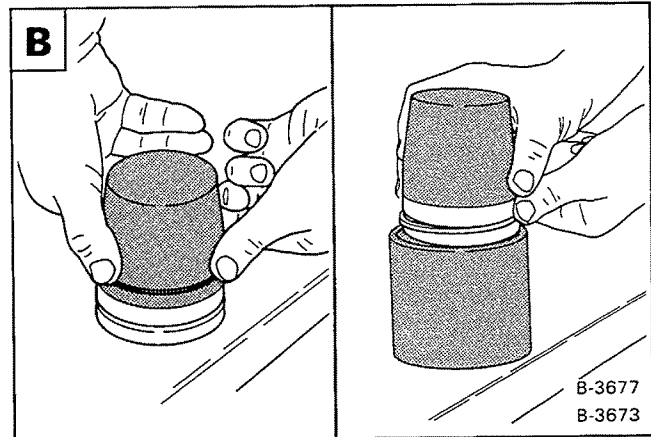

Install the seal on the seal tool **C**.

Install the seal in the end cap **C**.

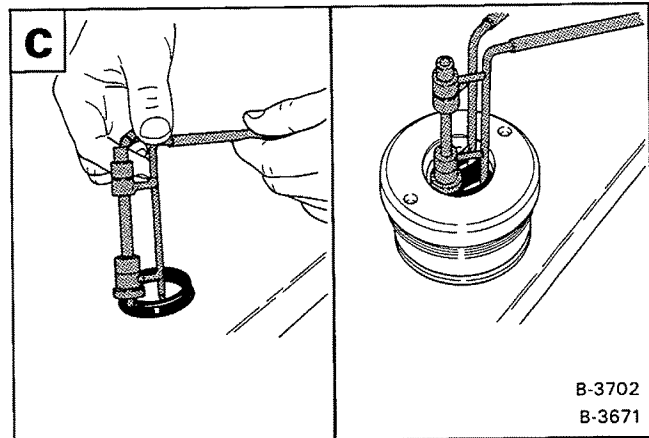

Install the wiper seal with the lip toward the outside of the end cap **D**.

**NOTE:** The O-ring side of the oil seal goes toward the inside of the cylinder.

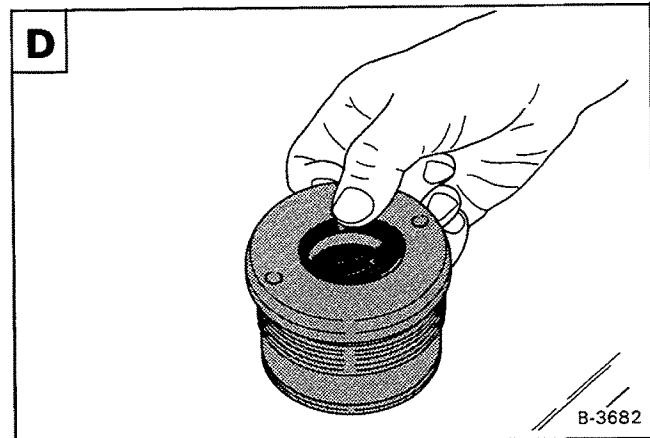





## HYDRAULIC CYLINDER REPAIR (Cont'd)

Inspect the cylinder barrel bore for scratches.

Put oil on the seals, O-rings and end cap threads **A**.

Install the assembly into the cylinder barrel.

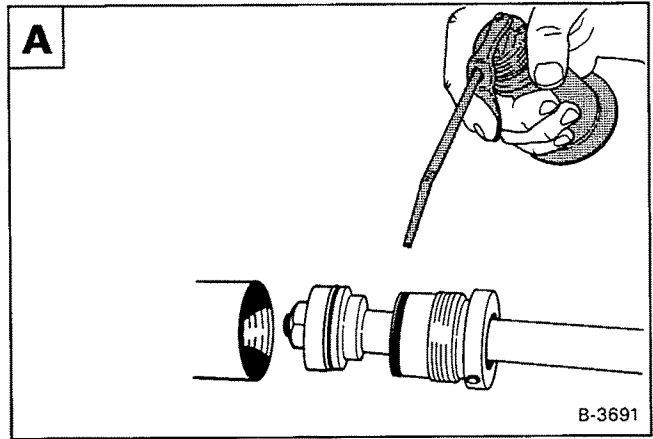

Tighten the end cap with the special tool **B**.

Push the cylinder rod in and out the full length of the cylinder barrel. It must travel freely through the full stroke of the cylinder with no binding.

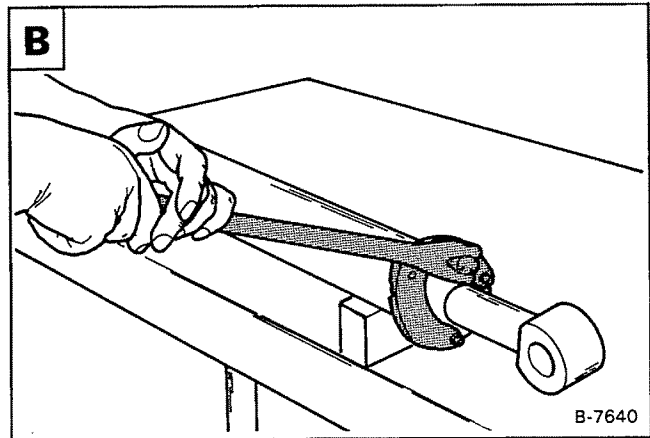

## HYDRAULIC CONTROL VALVE (CESSNA)

### Checking the Main Relief Valve

The tools listed will be needed to do the following procedure:

MEL-1238 — Hydraulic Tester  
MEL-10006 — Hydraulic Test Kit

Stop the engine. Activate the right steering lever (auxiliary hydraulics) to release the hydraulic pressure.

Lift and block the loader (See Page 1–2 for the correct procedure).

Connect the hydraulic tester to the auxiliary quick couplers **A**.

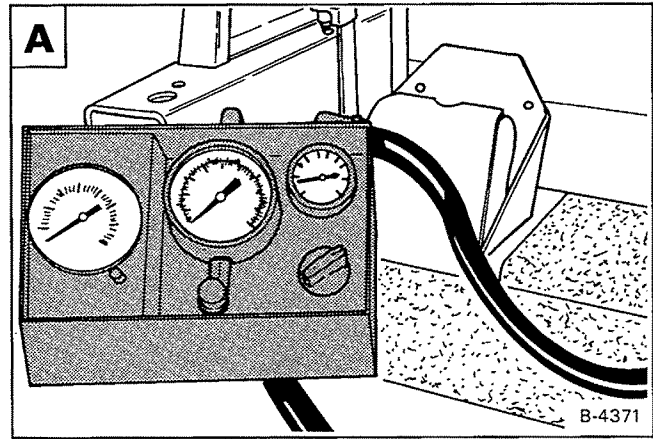

## IMPORTANT

The flow control tester must be in the fully open position before you start the engine to perform test.

I-2024-0284

Start the engine and run at idle RPM.

Engage the right steering lever into detent position. Watch the flow at the hydraulic tester to make sure it is correct.

Increase the engine RPM to maximum. There should be 15.5 GPM (58,8 L/min.) free flow.

The correct pressure for the main relief valve is 2150-2400 PSI (14824-16548 kPa).

If not, stop the engine.

Remove the main relief valve (See Page 2–19).

## IMPORTANT

Always keep hydraulic and hydrostatic parts clean. Clean outside of all assemblies before beginning repairs. Use plugs and caps to cover open ports. Dirt can quickly damage the system.

I-2021-0284

## HYDRAULIC CONTROL VALVE (CESSNA) (Cont'd)

### Main Relief Valve Removal and Installation

Activate the hydraulic controls to release the hydraulic pressure.

Raise the operator cab (See Page 1-7 for the correct procedure).

Clean the area around the control valve.

Loosen the main relief valve **A**.

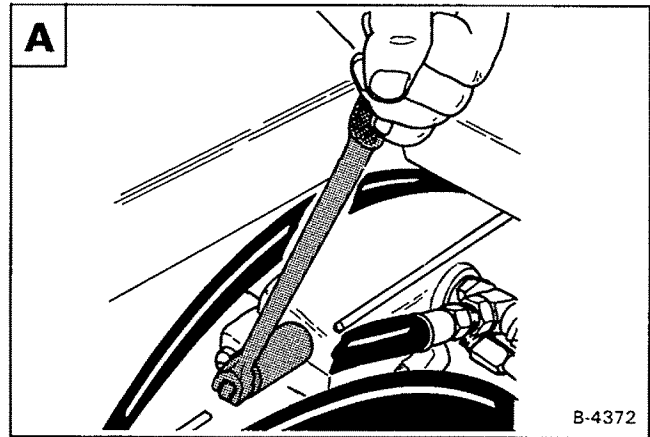

Remove the main relief valve from the control valve **B**.

Installation: When installing the main relief valve, always use NEW O-rings.

Clean and inspect the main relief valve.

Repeat the procedure for checking the relief valve. If the pressure is not correct, replace the main relief valve.

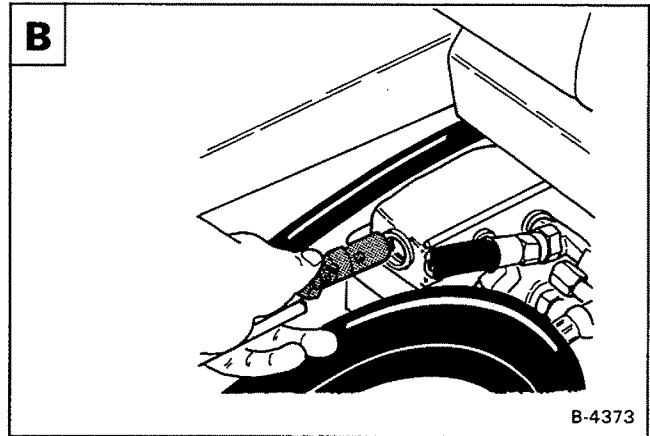

### Removal and Installation

Stop the engine. Activate the hydraulic controls to release the hydraulic pressure.

Lift and block the loader (See Page 1-2 for the correct procedure).

Raise the operator cab (See Page 1-7 for the correct procedure).

Remove the front panel (See Page 3-3 for the correct procedure).

Clean the area around the control valve.

Remove the hose from the control valve which goes to the port block **C**.

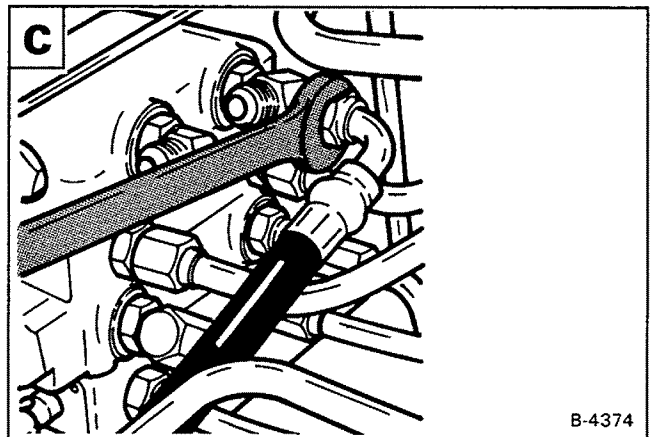

Disconnect the pedal control linkage at the valve spool **D**.

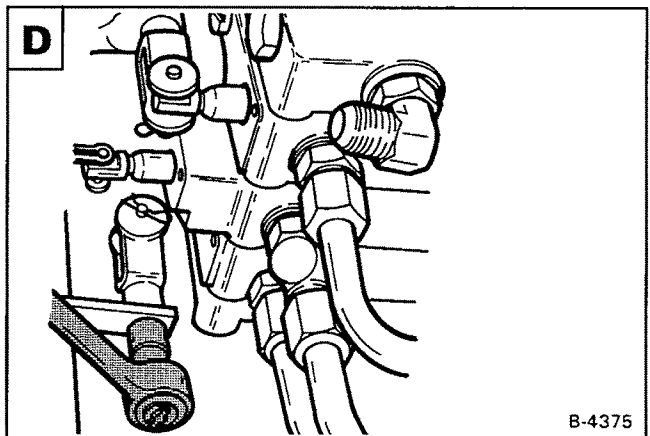

## HYDRAULIC CONTROL VALVE (CESSNA) (Cont'd)

Disconnect all the control linkage from the control valve **A**.

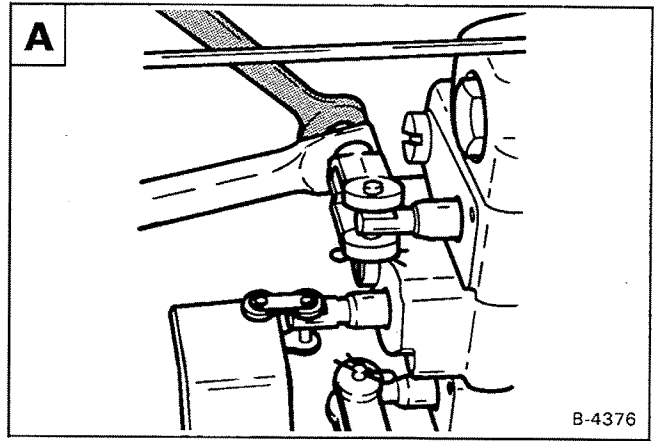

Disconnect all the tubelines from the control valve **B**.

Installation: When installing the tubelines, make sure the restrictor orifice is located in the port **B**.

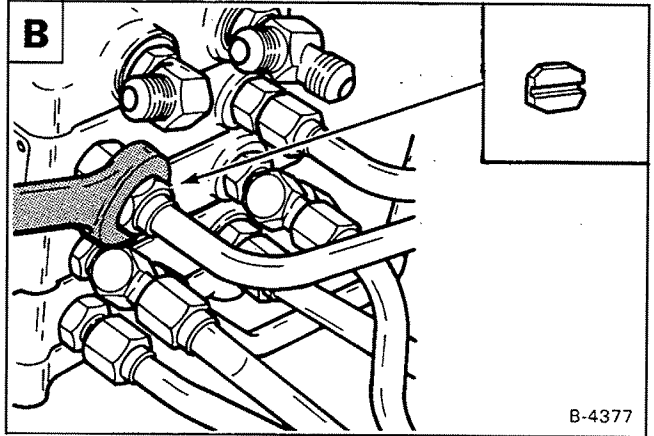

Disconnect the linkage at the throttle lever **C**.

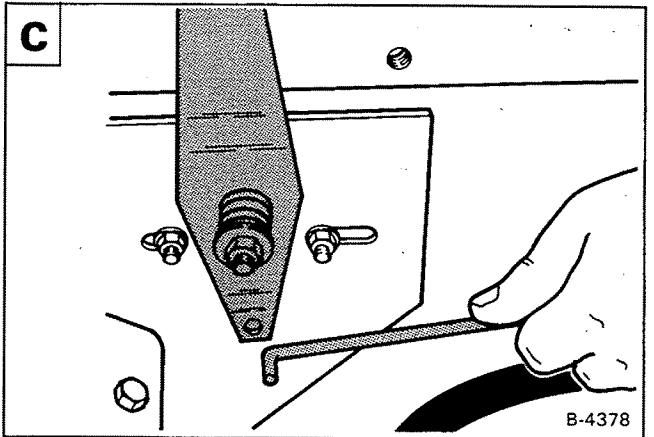

Remove the three bolts at the outside of the loader frame **D**.

Installation: Tighten the bolts to 25-28 ft.-lbs. (34-38 Nm) torque.

Remove the control valve from the loader.

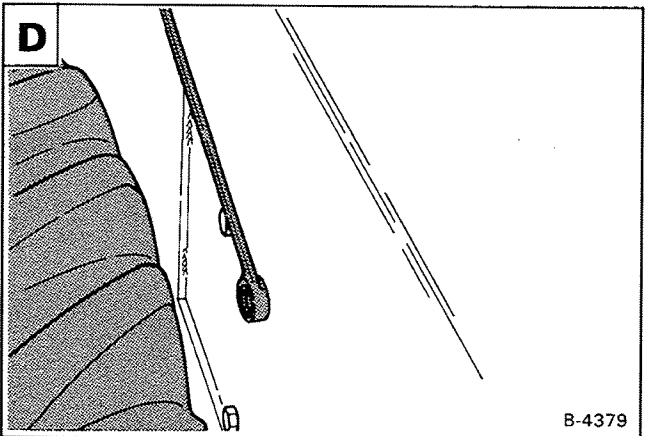

## HYDRAULIC CONTROL VALVE (CESSNA) (Cont'd)

### Disassembly

# IMPORTANT

Always keep hydraulic and hydrostatic parts clean. Clean outside of all assemblies before beginning repairs. Use plugs and caps to cover open ports. Dirt can quickly damage the system.

1-2021-0284

Mark each section of the control valve for identification for correct assembly **A**.

Remove the control valve thru-bolts **B**.

Remove the end section **C**.

Remove the auxiliary, lift and tilt sections **D**.

Remove all the O-rings and destroy them.

**NOTE:** Disassembly, repair and assembly must be done to one valve section at a time.

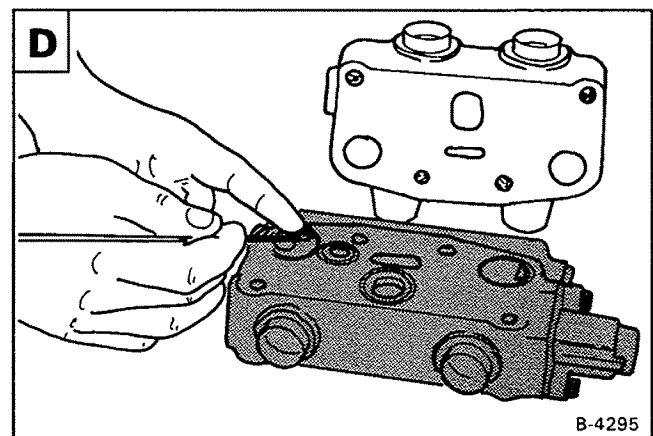
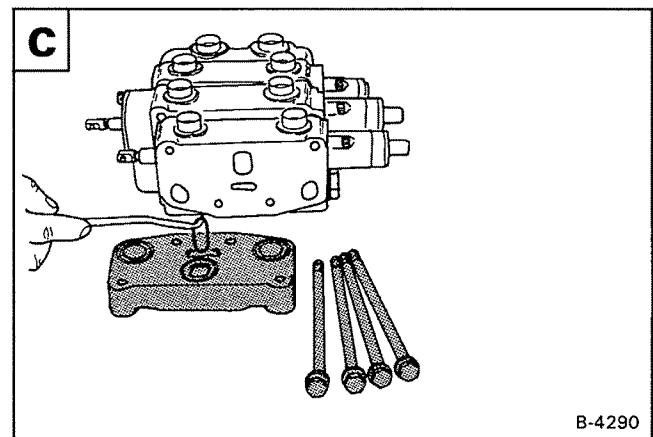
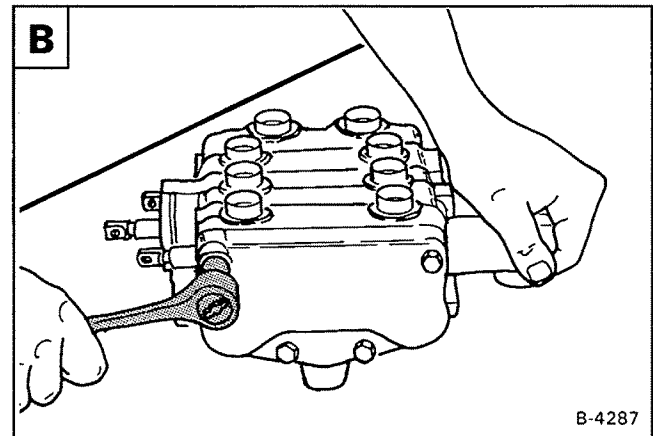
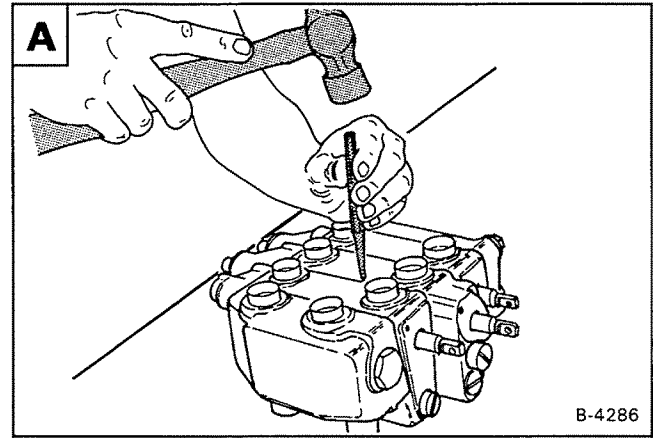

HYDRAULIC CONTROL VALVE (CESSNA) (Cont'd)

Inlet Section

Remove the main relief valve **A**.

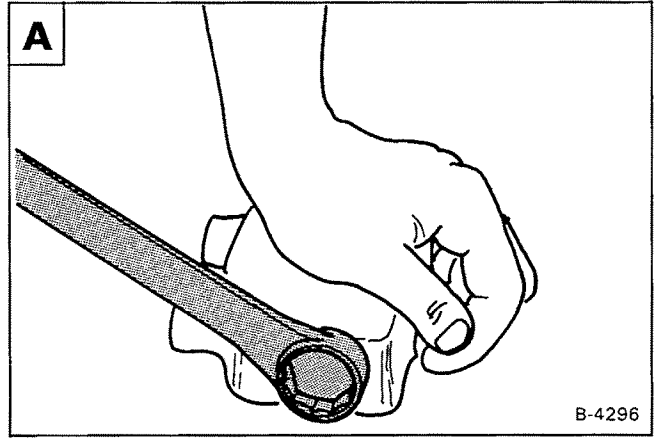

Remove the O-ring, back-up washer and O-ring from the port **B**.

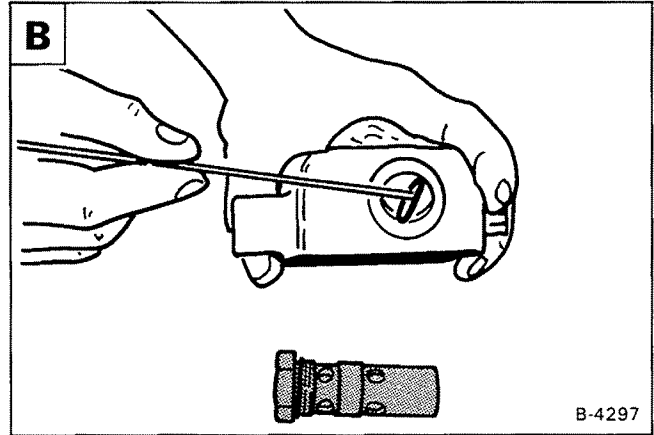

Remove the O-ring from the main relief valve **C**.

Clean and inspect the main relief valve and inlet section. Replace the parts as needed.

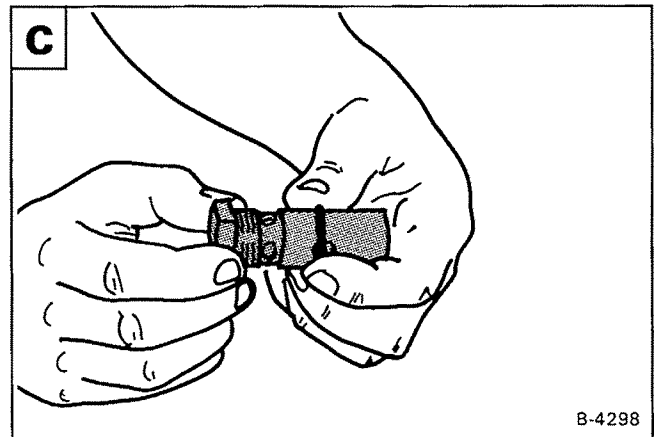

Installation: Make sure to install NEW O-rings and back-up washer in the inlet section **D**.

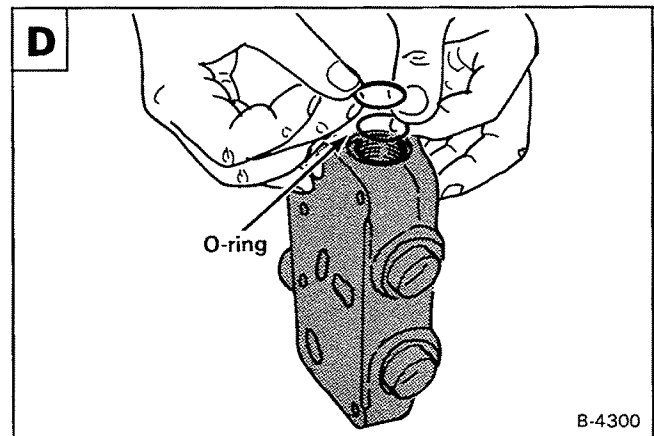

**HYDRAULIC CONTROL VALVE (CESSNA) (Cont'd)**

**Tilt Section**

Remove the bolts from the end cap **A**.

Installation: Tighten the bolts to 10-13 ft.-lbs. (14-17 Nm) torque.

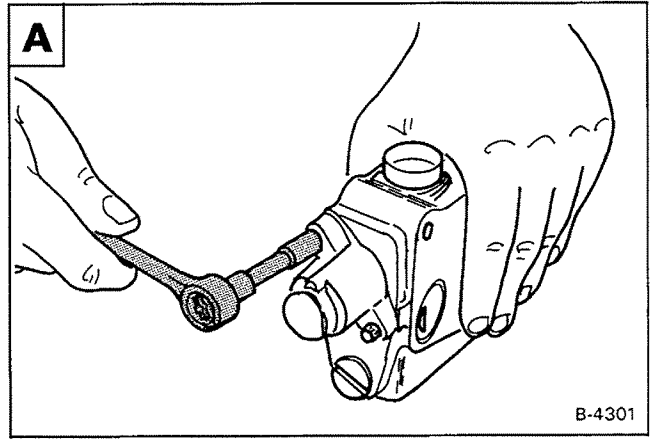

Remove the end cap **B**.

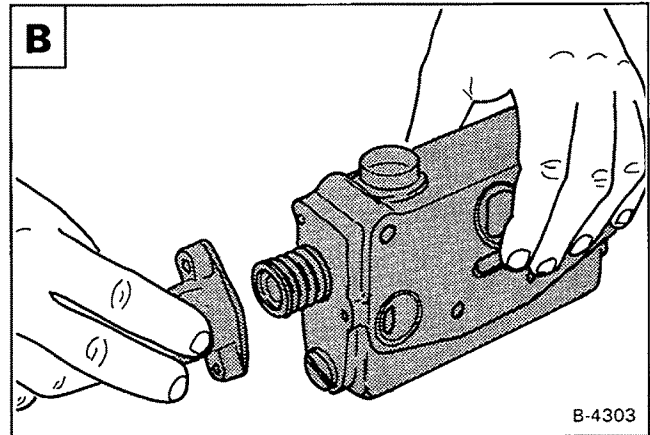

Remove the valve spool assembly **C**.

Installation: CAREFULLY install the spool from the rear of the valve section to prevent damage to the O-rings.

Installation: Check the valve spool, it must move freely in the bore. If not, rotate it 180°.

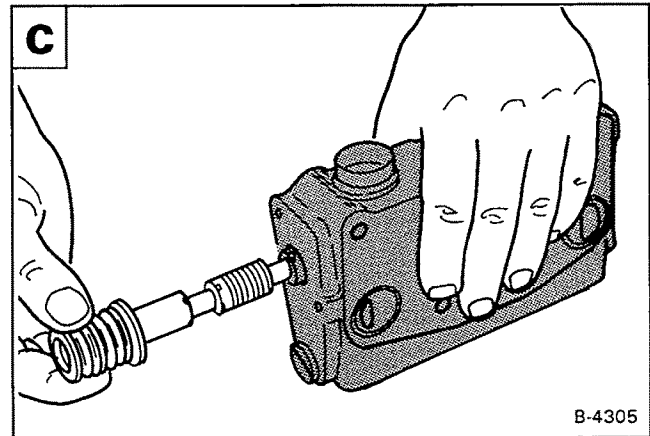

Remove the O-ring from the valve spool **D**.

Remove the O-rings from the valve spool bore **D**.

Installation: Always use NEW O-rings before installing the spool assembly.

**NOTE:** DO NOT remove the spool bolt from the valve spool unless the spring is broken. If the spool bolt is to be removed (See Page 2—28 for the correct procedure).

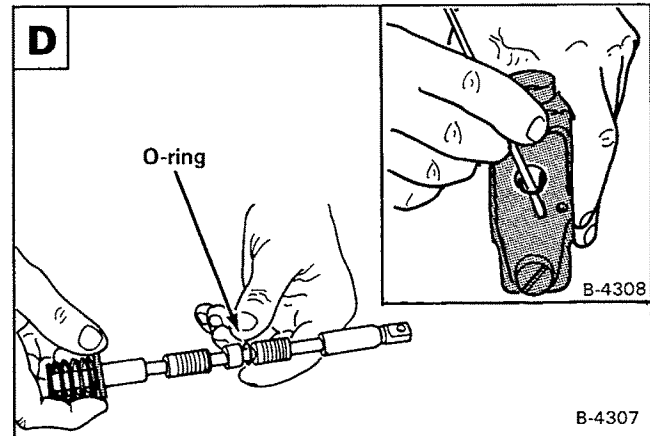



## HYDRAULIC CONTROL VALVE (CESSNA) (Cont'd)

Remove the plug for the load check valve **A**.

Remove the spring and poppet **A**.

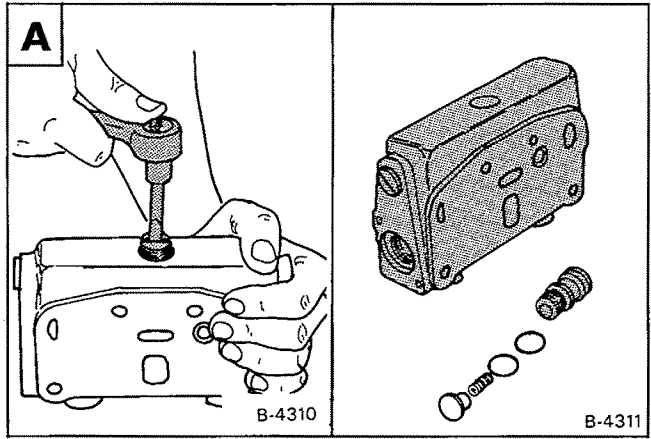

Remove the plug for the check valve **B**.

Remove the spring and poppet **B**.

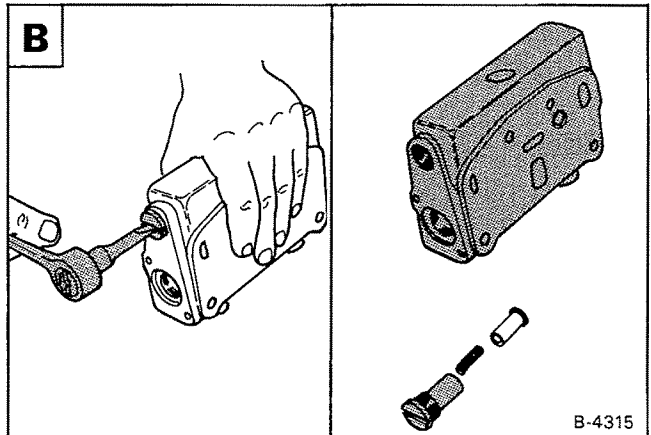

Remove the plug at the unloading valve **C**.

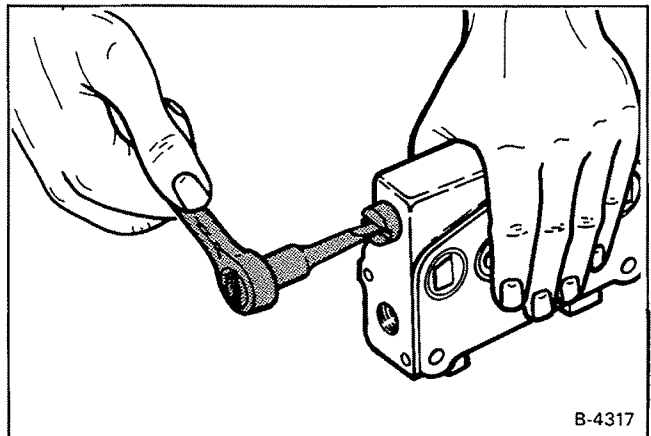

Remove the spring and unloading valve **D**.

Clean and inspect all the parts.

Replace the parts as needed.

Remove and destroy all the O-rings.

Always use NEW O-rings when assembling the valve section.

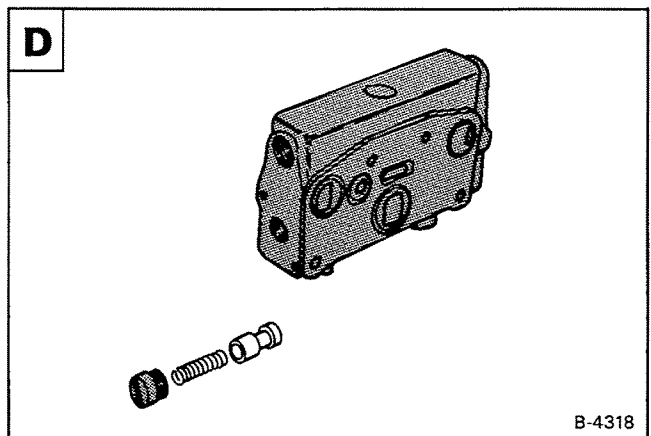

Copyright © 2004, Deere & Company. All rights reserved. Printed in the USA. 11/04 (10/03)

## HYDRAULIC CONTROL VALVE (CESSNA) (Cont'd)

### Lift Section

Remove the bolts from the end cap **A**.

Installation: Tighten the bolts to 10-13 ft.-lbs. (14-17 Nm) torque.

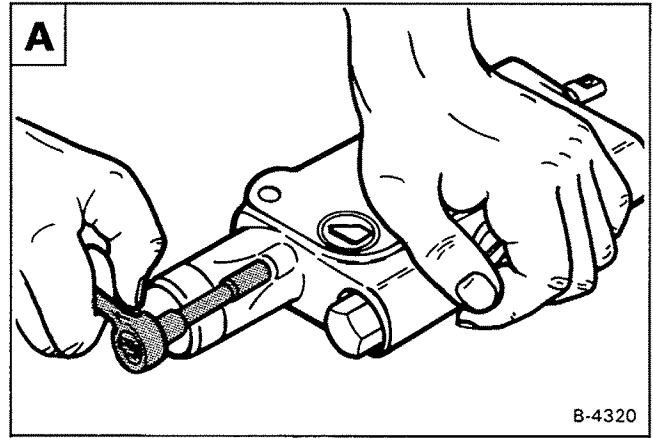

Remove the end cap **B**.

**NOTE:** When installing the end cap, make sure the detent holds the spool.

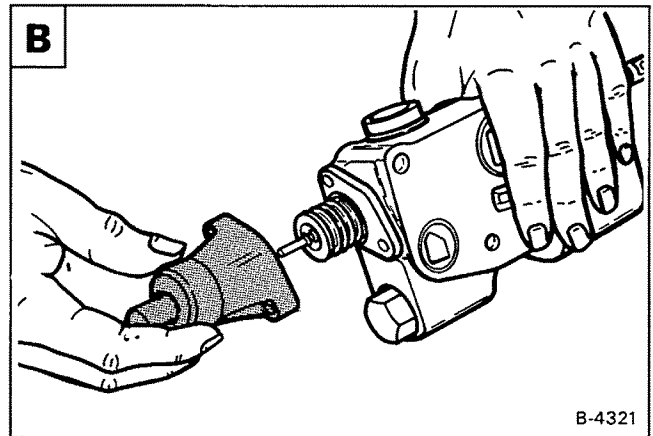

Remove the valve spool assembly **C**.

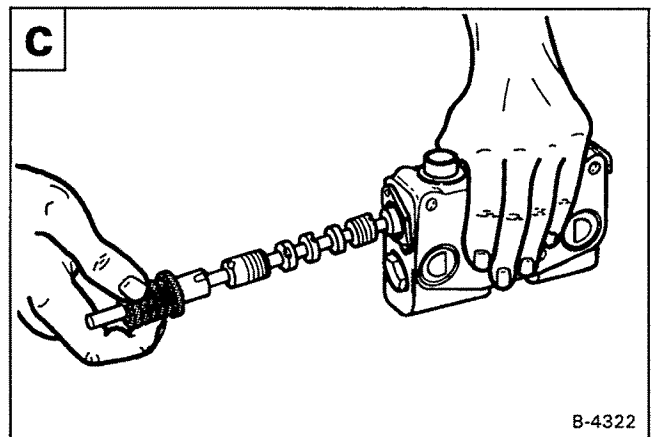

Remove the O-ring from the valve spool **D**.

Installation: Check the valve spool so it operates freely in the bore. If not, rotate the spool 180°.

Remove the O-rings at both ends of the valve spool bore in the valve section.

**NOTE:** DO NOT remove the spool bolt from the valve spool unless the spring is broken. If the bolt is to be removed, (See Page 2-28 for the correct procedure).

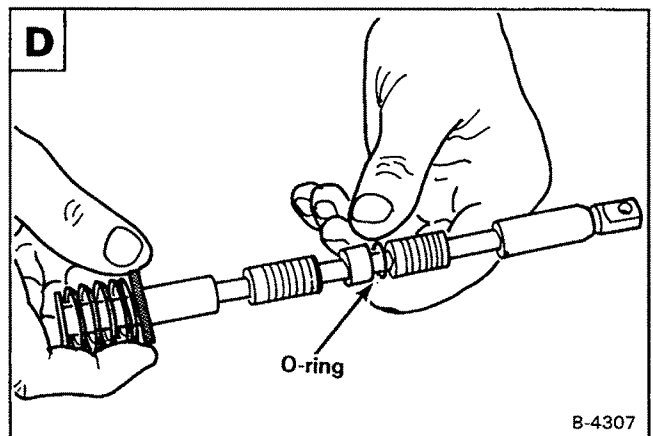



## HYDRAULIC CONTROL VALVE (CESSNA) (Cont'd)

### Auxiliary Section

Remove the bolts from the end cap **A**.

Installation: Tighten the bolts to 10-13 ft.-lbs. (14-17 Nm) torque.

Remove the end cap.

**NOTE:** When installing the end cap, make sure the detent holds the spool.

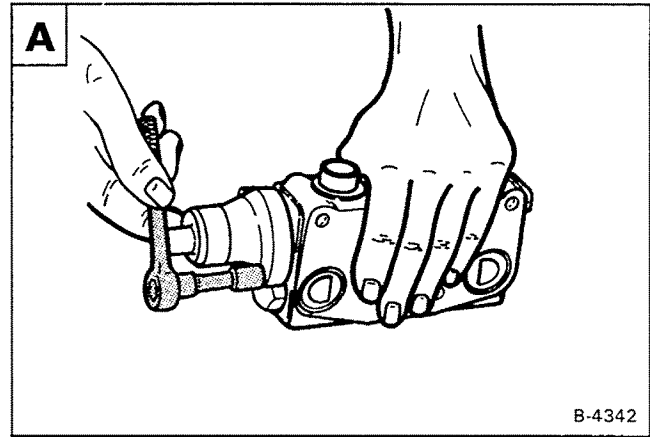

Remove the valve spool assembly **B**.

Installation: Check the valve spool so it operates freely in the bore. If not, rotate the spool 180°.

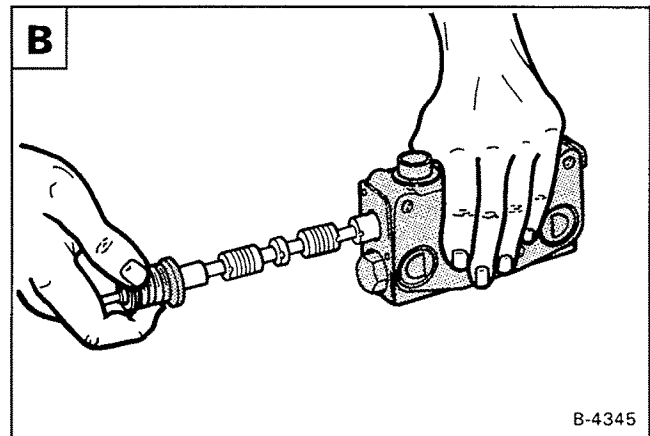

Remove the O-ring from the valve spool **C**.

Remove the O-rings at both ends of the valve spool bore in the section.

**NOTE:** DO NOT remove the spool bolt from the valve spool unless the spring is broken. If the bolt is removed See Page 2-28 for the correct procedure.

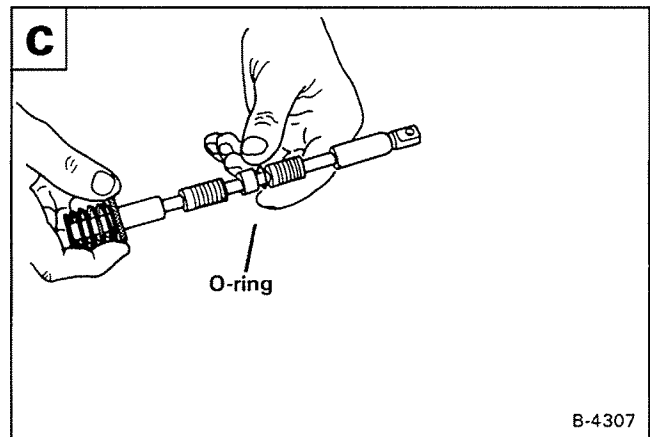

Remove the plug at the load check valve **D**.

Remove the spring and poppet **D**.

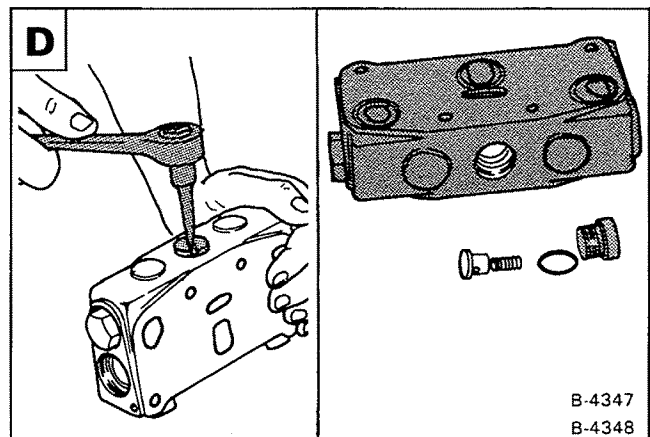

## HYDRAULIC CONTROL VALVE (CESSNA) (Cont'd)

Remove the flow plug **A**.

Clean and inspect all the parts. Replace the parts as needed.

Remove and destroy all the O-rings.

Always use NEW O-rings when assembling the auxiliary section.

### Valve Spool Bolt

To remove the spool bolt, follow this procedure:

## IMPORTANT

The spool bolt is held tightly by Loc-tite. Failure to heat the spool will cause breakage of the spool bolt.

1. Heat the spool where the spool bolt turns into the spool to about 400°F (205°C) **B**.
2. Use a deep socket and remove the spool bolt.
3. Install a NEW O-ring (Item 1) on the spool **C**.
4. Install the washer (Item 2), spring cap (Item 3), spring (Item 4) and spring cap (Item 5).
5. Put Loctite on the spool bolt (Item 6) and install it in the spool **C**.

6. Tighten the spool bolt to 60-96 in.-lbs. (6,8-10,8 Nm) torque **D**.

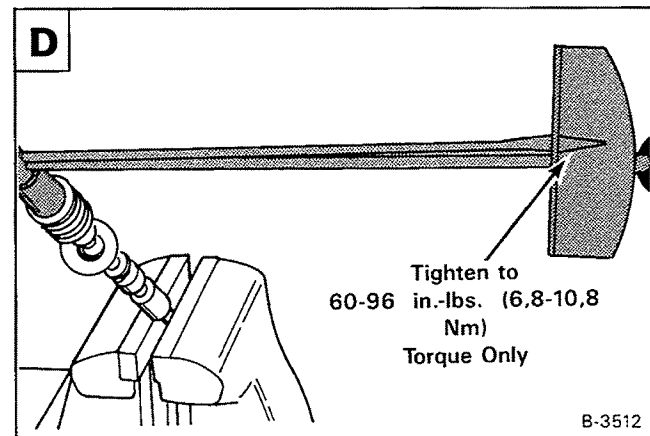
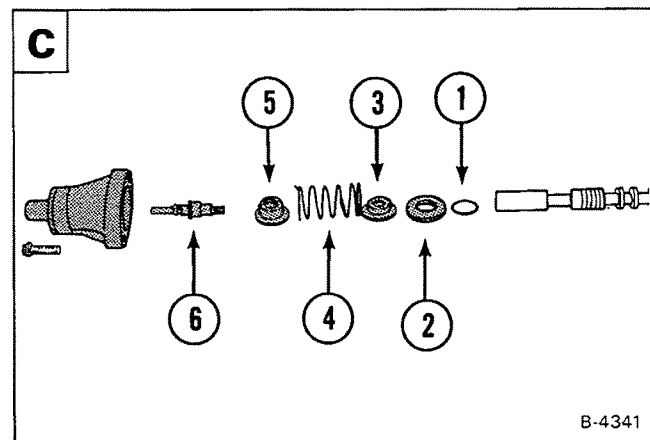
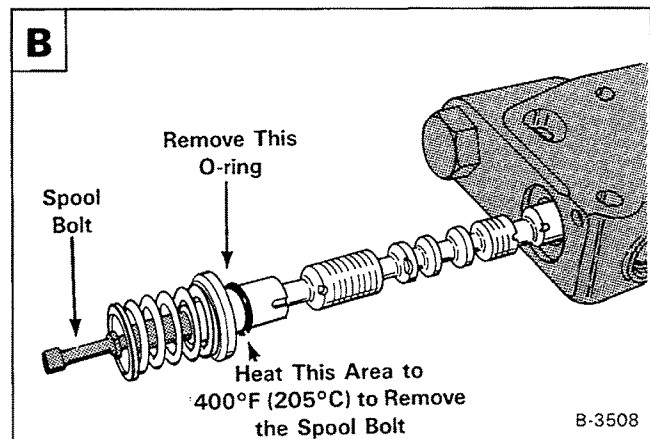
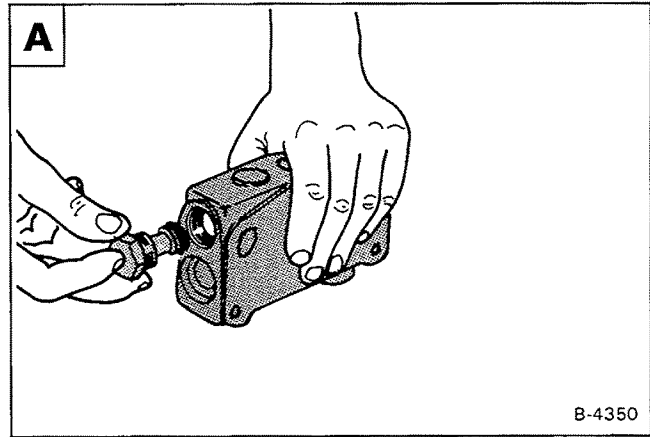

## HYDRAULIC CONTROL VALVE (CESSNA) (Cont'd)

### Assembly

**NOTE:** Use vaseline or grease to hold the O-rings in their correct location between each section when assembling the valve sections.

Put the inlet section in the vise.

Install the auxiliary section (Item 1) **A**.

Install the lift section (Item 2) **A**.

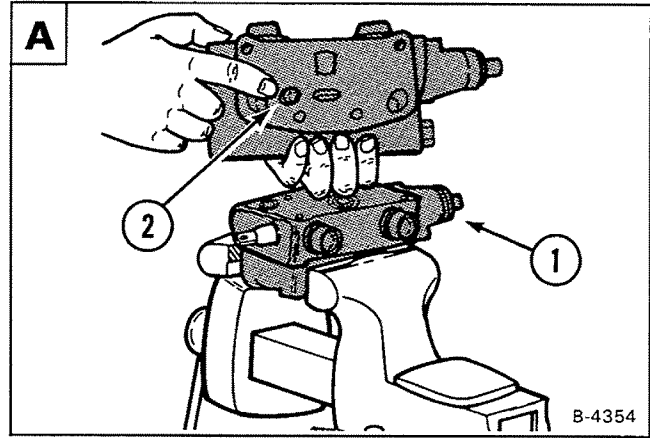

Install the tilt section (Item 1) **B**.

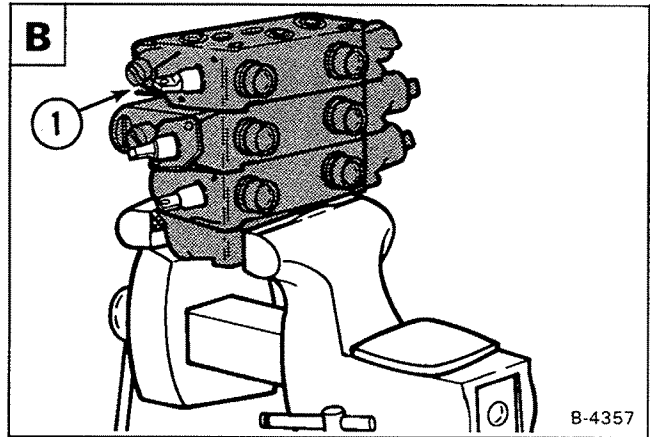

Install the end section (Item 1) **C**.

Install the thru-bolts (Item 2) and finger tighten only.

Remove the control valve from the vise. Set the control valve on a flat surface to make alignment of all the valve sections.

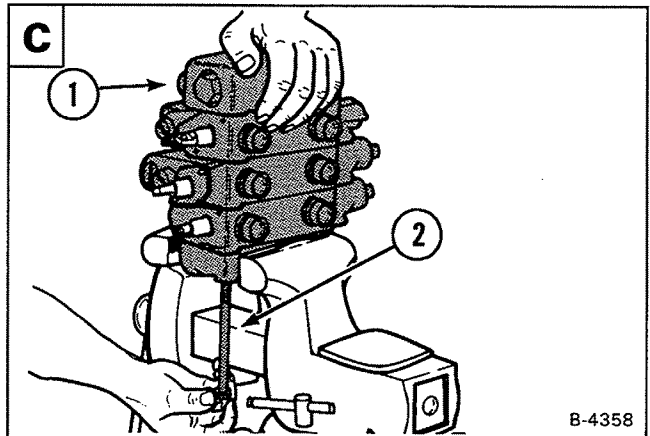

Tighten the bolts to 22 ft.-lbs. (30 Nm) torque **D**.

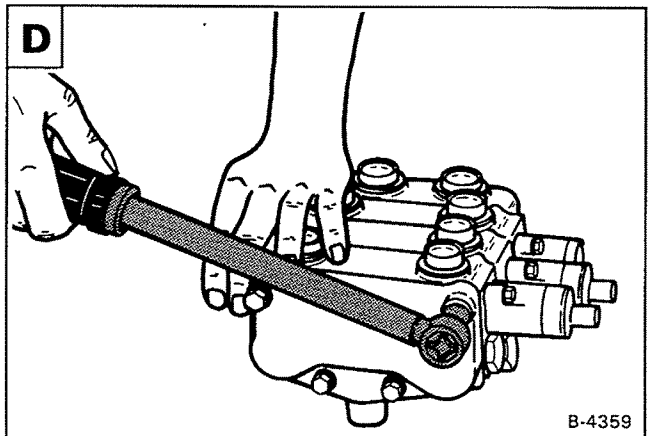

## HYDRAULIC CONTROL VALVE (MELROE)

### Checking the Main Relief Valve

The tools listed will be needed to do the following procedure:

MEL-1238 — Hydraulic Tester  
MEL-10006 — Hydraulic Test Kit

Stop the engine. Activate the right steering lever (auxiliary hydraulics) to release the hydraulic pressure.

Lift and block the loader (See Page 1–2 for the correct procedure).

Connect the hydraulic tester to the auxiliary quick couplers **A**.

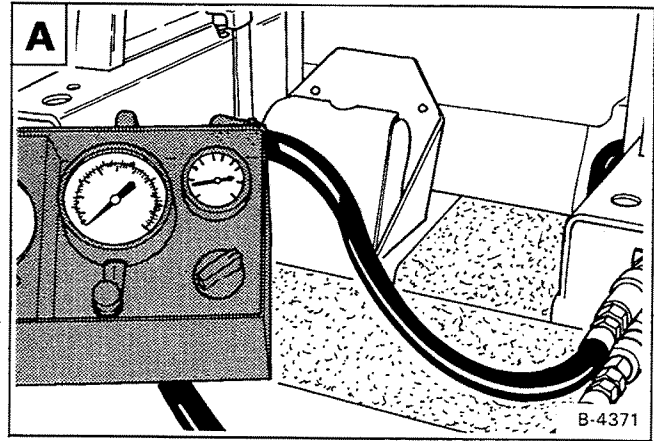

## IMPORTANT

The flow control tester must be in the fully open position before you start the engine to perform test.

I-2024-0284

Start the engine and run at idle RPM.

Engage the right steering lever into the detent position. Watch the flow at the hydraulic tester to make sure it is correct.

Increase the engine RPM to maximum. There should be 15.5 GPM (58,8 L/min.) free flow.

The correct pressure for the main relief valve is 2250-2400 PSI (15514-16548 kPa) measured at the quick couplers.

If not, stop the engine.

Replace or adjust the main relief valve (See Page 2–31).

## IMPORTANT

Always keep hydraulic and hydrostatic parts clean. Clean outside of all assemblies before beginning repairs. Use plugs and caps to cover open ports. Dirt can quickly damage the system.

I-2021-0284

## HYDRAULIC CONTROL VALVE (MELROE) (Cont'd)

### Main Relief Valve Removal and Installation

Move the hydraulic controls to release the hydraulic pressure.

Open the rear door. The main relief valve (Item 1) is located on the rear of the control valve on the right side **A**.

Clean the area around the main relief valve.

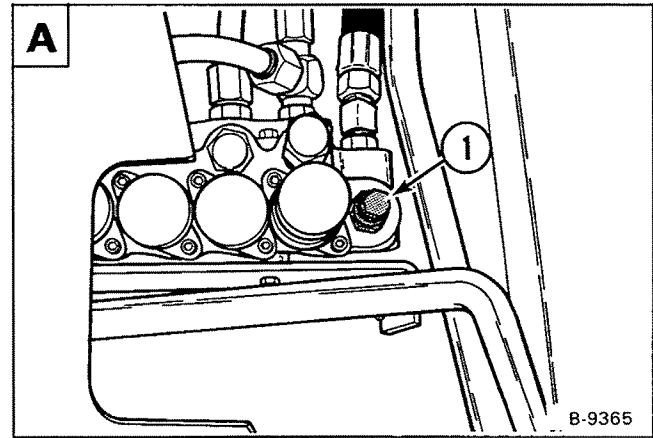

Using a deep socket and extension, remove the main relief valve **B**.

Installation: When installing the main relief valve, always use NEW O-rings.

Clean and inspect the relief valve.

Repeat the procedure for checking the main relief valve, if the pressure is not correct do the following procedure:

Remove the cap (Item 1) from the main relief valve **A**. Using an allen wrench, adjust the relief valve until the pressure is correct.

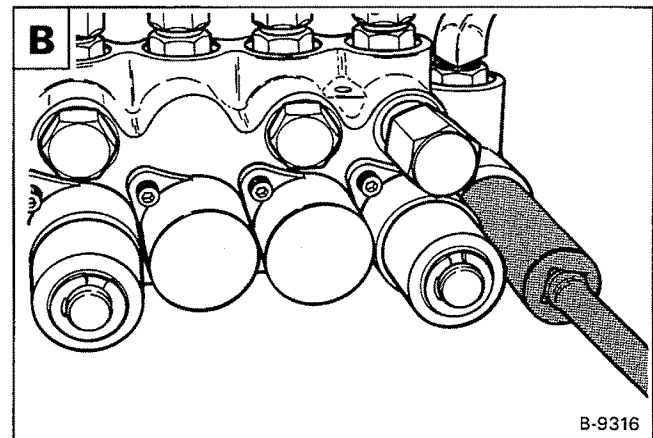

### Removal and Installation

**NOTE:** The 843B loader control valve is a 3 spool valve, but the procedure for removal and installation is the same.

Stop the engine. Move the hydraulic controls to release the hydraulic pressure.

Lift and block the loader (See Page 1-2 for the correct procedure).

Raise the operator cab (See Page 1-7 for the correct procedure).

Clean the area around the control valve.

Remove the high pressure hoses from the hydrostatic pumps **C**.

Disconnect the auxiliary linkage from the control valve spool **D**.

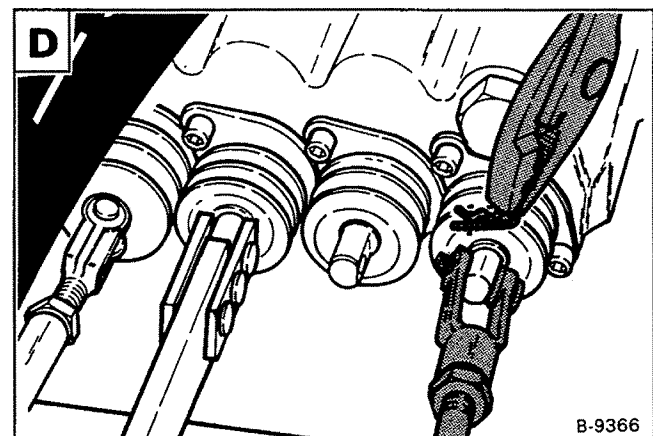
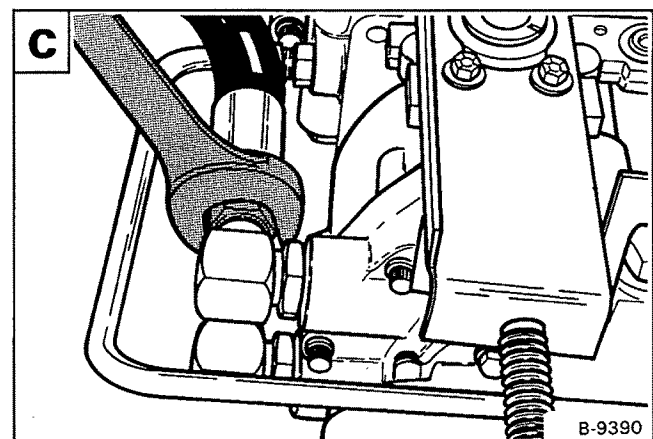



### HYDRAULIC CONTROL VALVE (MELROE) (Cont'd)

Disconnect the lift and tilt linkage from the control valve spools **A**.

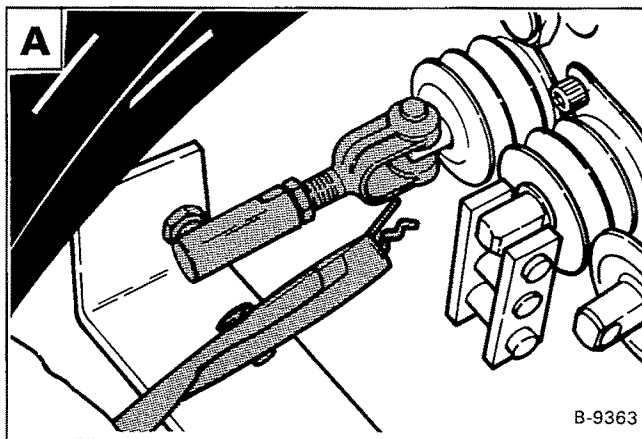

Disconnect all the tubelines from the control valve **B** **C**.

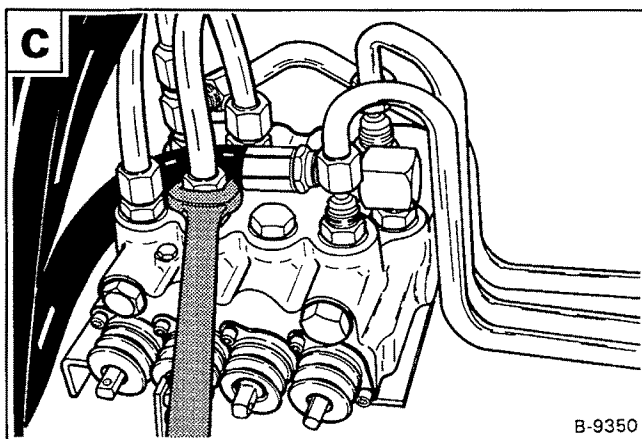
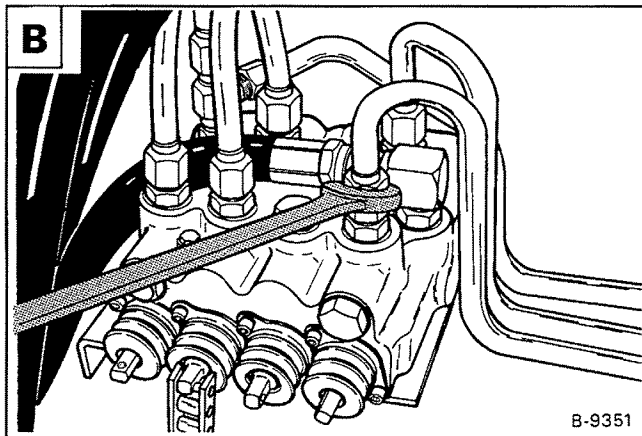

Disconnect the inlet and outlet hoses from the control valve **D**.

Remove the mounting bolts from the control valve. Remove the control valve from the loader.

Installation: Tighten the mounting bolts to 180-200 in.-lbs. (21-23 Nm) torque.

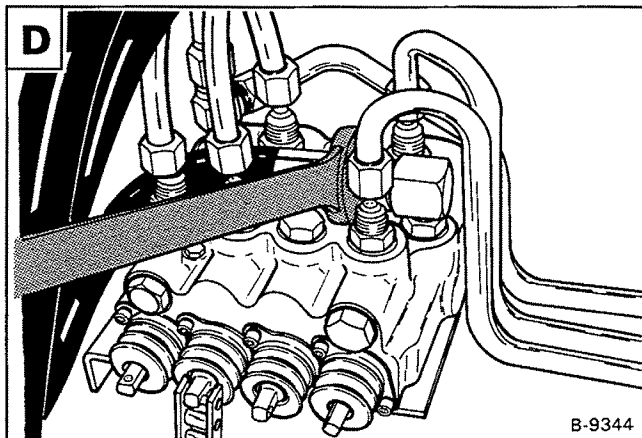

## HYDRAULIC CONTROL VALVE (MELROE) (Cont'd)

### Disassembly and Assembly

**NOTE:** The 843B control valve is a 3 spool valve. The D3 rear auxiliary section is NOT there, but the procedure for disassembly and assembly is the same.

Mark each spool and section for correct assembly.

Check the control valve layout before disassembly for correct identification and location of the parts **A**.

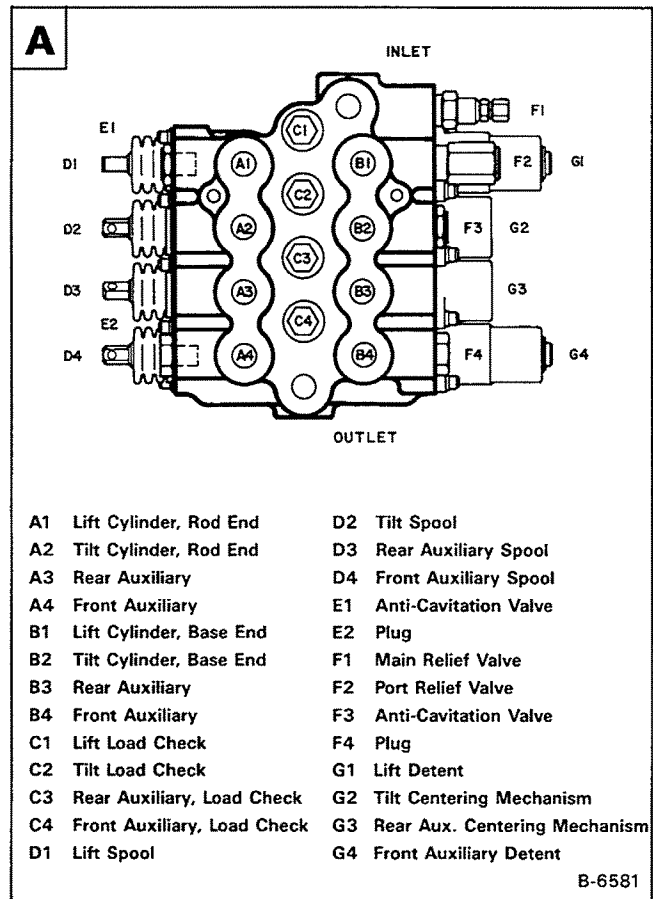

Remove the load check valves (Item 1) from the four center ports **B**.

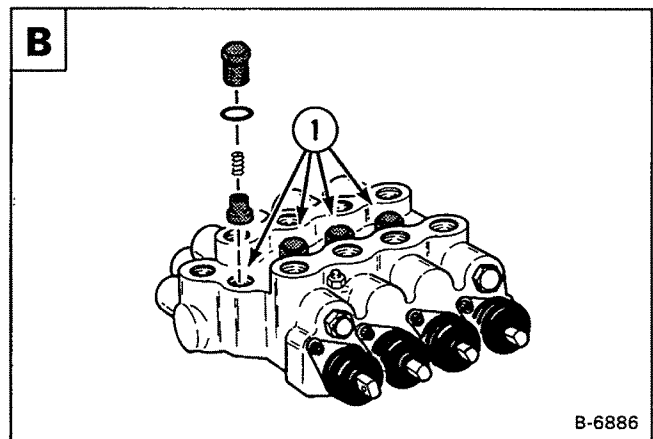

Remove the port relief valve from the lift section **C**.

Remove the O-rings and back-up washer.

Assembly: Always use NEW O-rings and back-up washer. Tighten to 35-40 ft.-lbs. (47-54 Nm) torque.

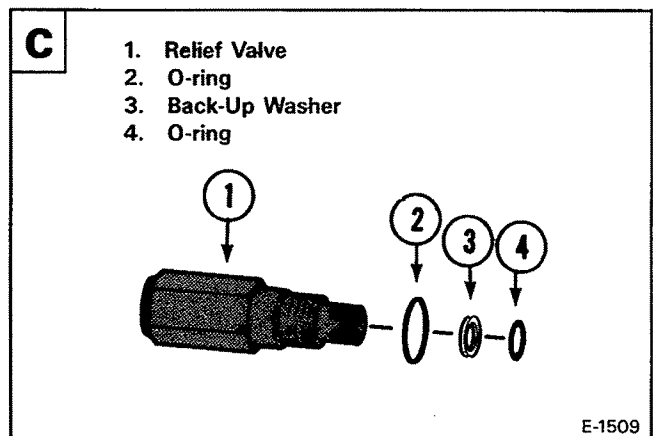

**HYDRAULIC CONTROL VALVE (MELROE) (Cont'd)**

Remove the anti-cavitation valves from the spool end of the lift section and base end of the tilt section.

Remove the O-rings and back-up washer **A**.

Assembly: Always use NEW O-rings and back-up washer. Tighten to 35-40 ft.-lbs. (47-54 Nm) torque.

Remove the plugs from the spool end and base end of the front auxiliary section.

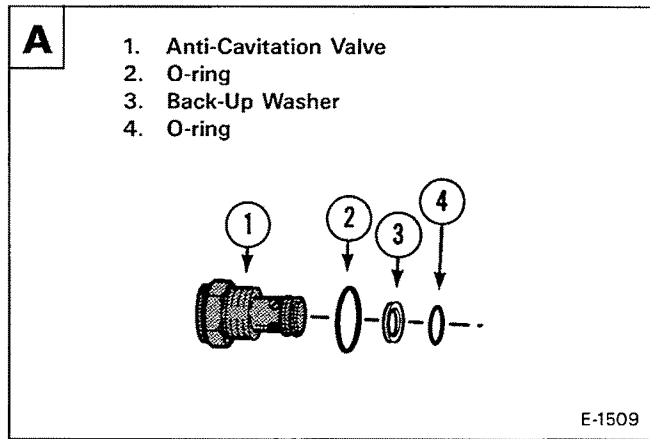

Remove the O-rings and back-up washer **B**.

Assembly: Always use NEW O-rings and back-up washer. Tighten to 35-40 ft.-lbs. (47-54 Nm) torque.

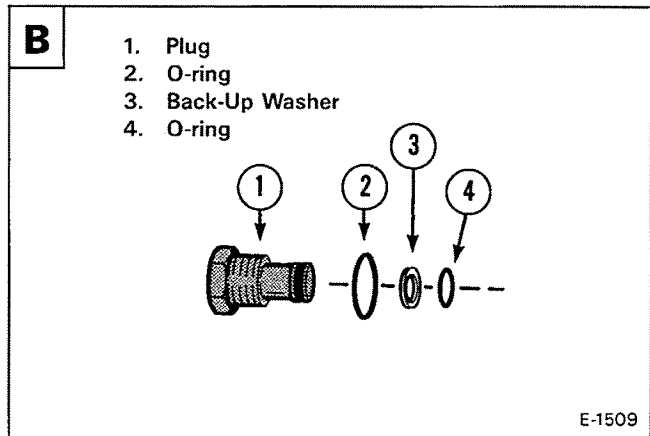

Remove the main relief valve from the control valve **C**.

Remove the O-rings and back-up washers **C**.

Assembly: Always use NEW O-rings and back-up washers. Tighten to 35-40 ft.-lbs. (47-54 Nm) torque.

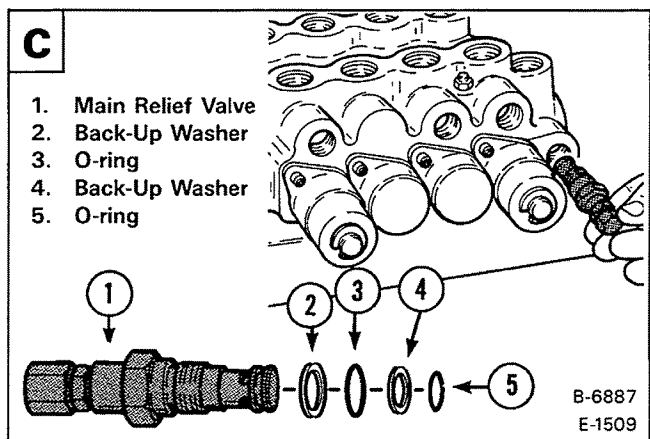

Remove the screws which fasten the rubber boot retainer to the valve **D**.

Assembly: Tighten the screws to 90-100 in.-lbs. (10-11 Nm) torque.

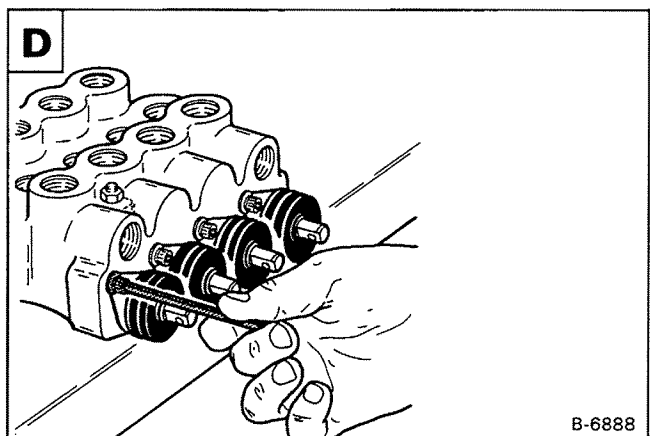

page 403 - BUSHING/VALVE/PLUG - 04/10/2009 1:15:09 - PRINTED BY KEN COOK CO. - exprint.exe (v2.24.3 8/25/2008)

## HYDRAULIC CONTROL VALVE (MELROE) (Cont'd)

Remove the retainer, rubber boot and bronze filter **A**.

Repeat this procedure for the other valve spools.

### Detent Assembly

The tool listed will be needed to do the following procedure:

MEL-1278 — Detent Tool

The lift spool and the front auxiliary spool have a detent and float position. Use the following procedure to disassemble and assemble the detent assembly for either the lift or auxiliary spool.

The detent sleeves are not the same:

Lift detent has a inside depth of 1.160" (29,5 mm).

Auxiliary detent has a inside depth of 1.061" (26,9 mm).

Remove the snap ring and washer **B**.

Remove the screws securing the detent cap **C**.

Assembly: Tighten the screws to 90-100 in.-lbs. (10-11 Nm) torque.

Remove the detent cap.

Remove the detent sleeve and detent balls and spring.



## WARNING

Wear safety glasses to prevent eye injury when any of the following conditions exist:

- When fluids are under pressure.
- Flying debris or loose material is present.
- Engine is running.
- Tools are being used.

W-2019-1285

Remove the centering spring bolt **D**.

**NOTE:** Carefully remove the centering spring bolt, because there is spring pressure.

Remove the spool from the bore.

Remove the front and rear O-rings.

Revised Sept. 90

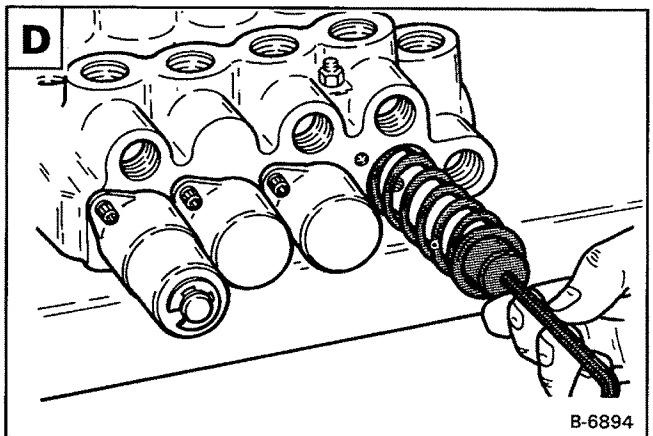
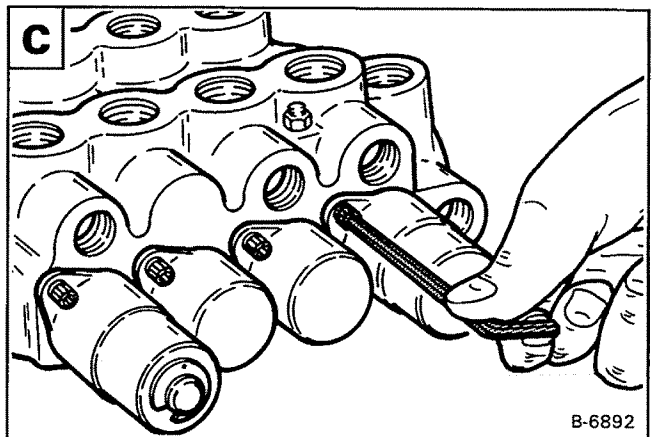
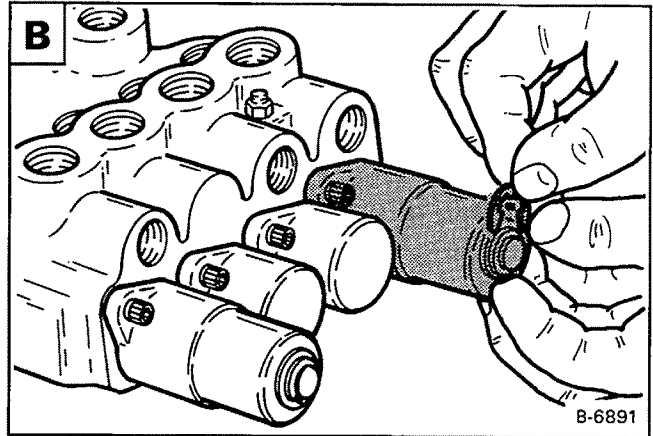
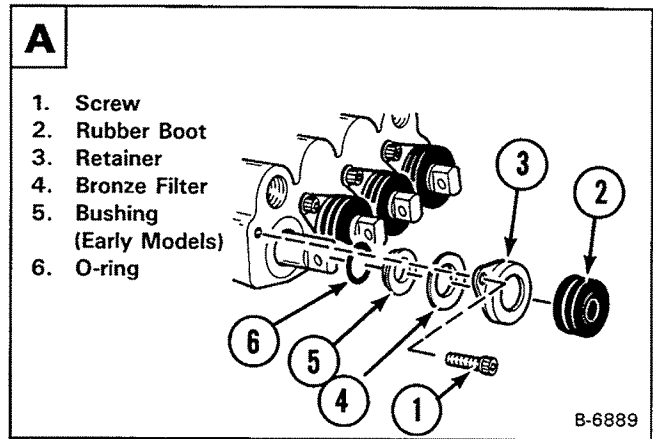

843 Loader  
Service Manual

HYDRAULIC CONTROL VALVE (MELROE) (Cont'd)

NOTE: It is not necessary to remove the spool from the bore completely on the counter-bored valve with a bushing **A**.

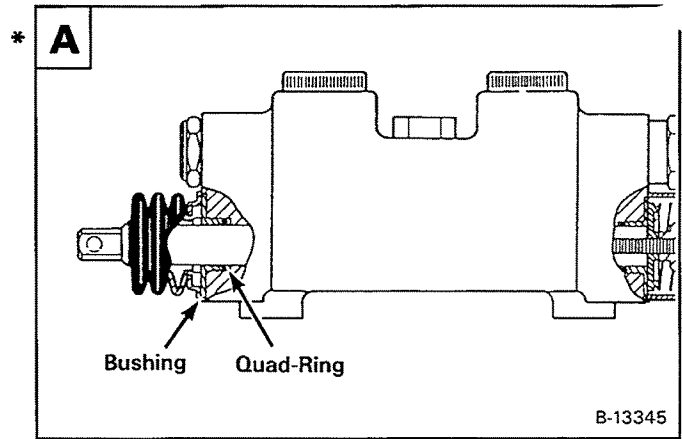

Install a NEW O-ring in the groove at the front of the control valve **B**.

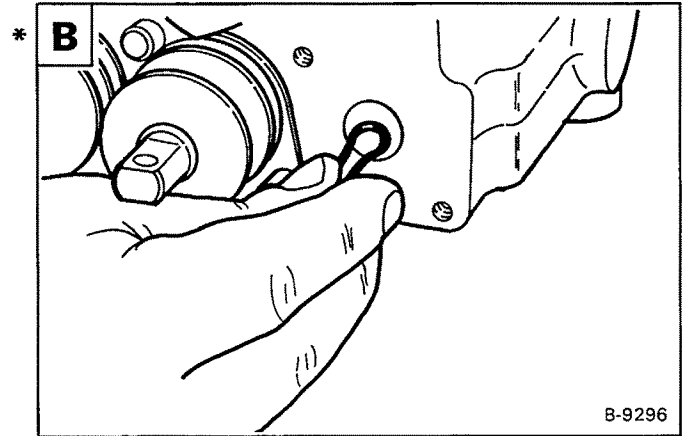

Install the valve spool into the control valve from the rear of the control valve. Push the spool into the valve just far enough so that the rear O-ring can be installed **C**.

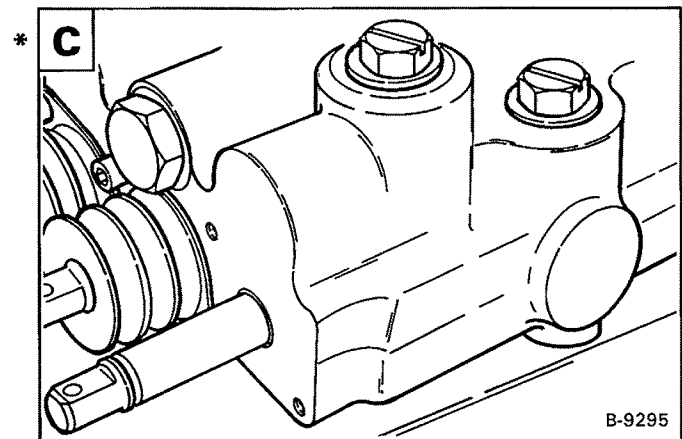

Install the NEW rear O-ring **D**.

Push the valve spool back into the control valve until it is even with the rear machined surface of the control valve.

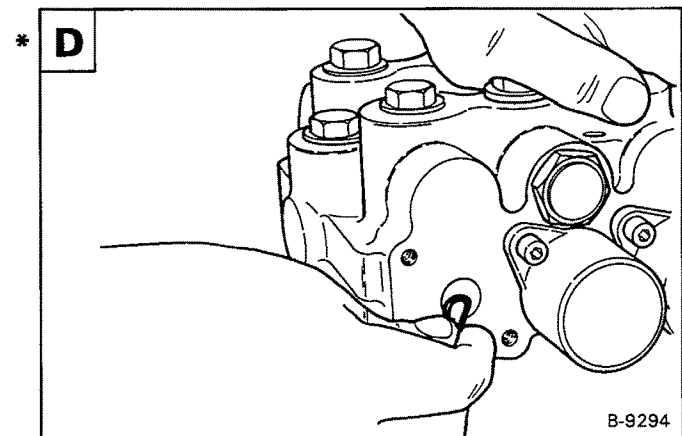

## HYDRAULIC CONTROL VALVE (MELROE) (Cont'd)

Put the detent adapter into a vise.

Install the detent spring **A**.

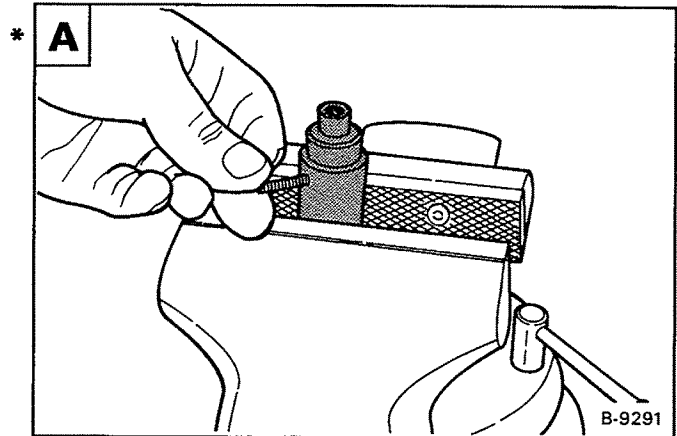

Put grease on the jaws of the detent tool. Put the detent balls on the jaws of the detent tool **B**.

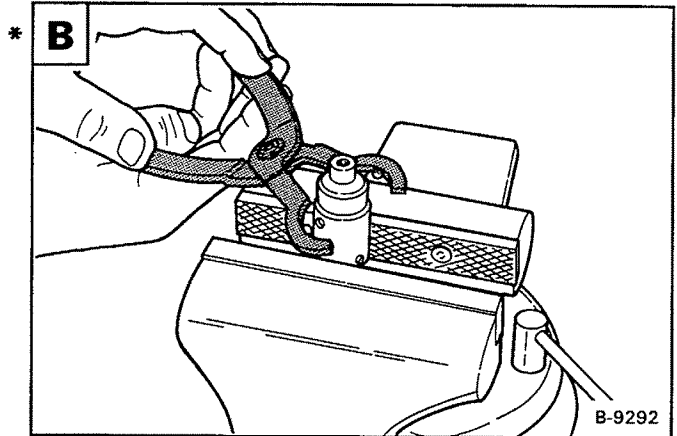

Hold the detent balls in position. Install the spring end cap over the detent adapter **C**.

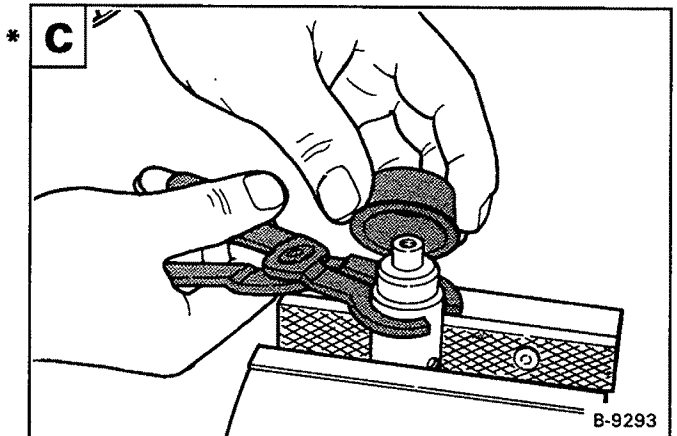

Remove the detent adapter and spring cap assembly from the vise.

Install the centering spring and the other spring cap on the spool and tighten the adapter to 90-100 in.-lbs. (10-11 Nm) torque.

Install the detent spring into the detent adapter **D**.

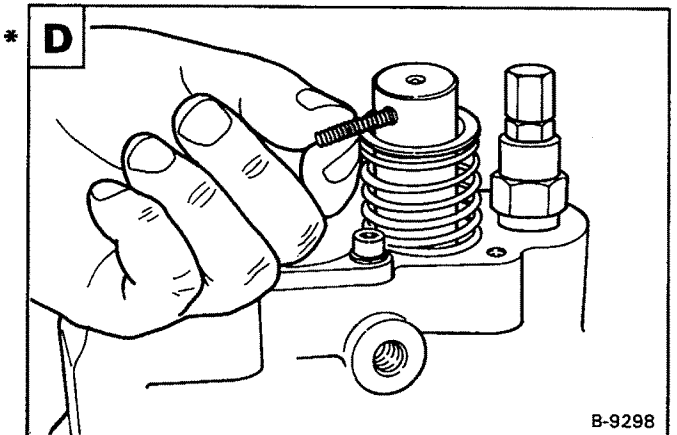

## HYDRAULIC CONTROL VALVE (MELROE) (Cont'd)

Hold the detent balls in position with the detent tool and slide the detent sleeve into position **A**.

Install the detent cap. Tighten the screw to 90-100 in.-lbs. (10-11 Nm) torque.

Install the washer and snap ring on the end of the detent sleeve.

### Centering Mechanism

The tilt and rear auxiliary spool have a centering spring. Use the following procedure to disassemble and assemble the center mechanism for either spool.

Remove the screws securing the cap **B**.

Assembly: Tighten the screws to 90-100 in.-lbs. (10-11 Nm) torque.

Remove the cap. Remove the centering spring bolt **C**.

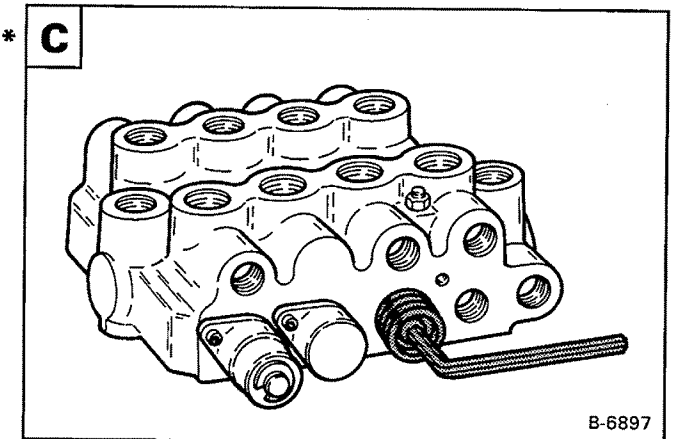
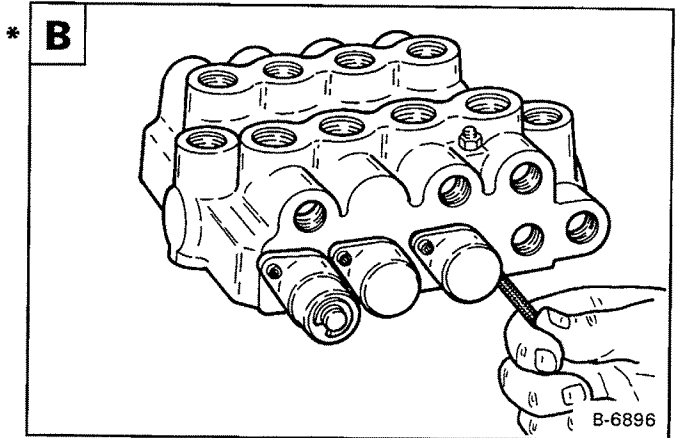
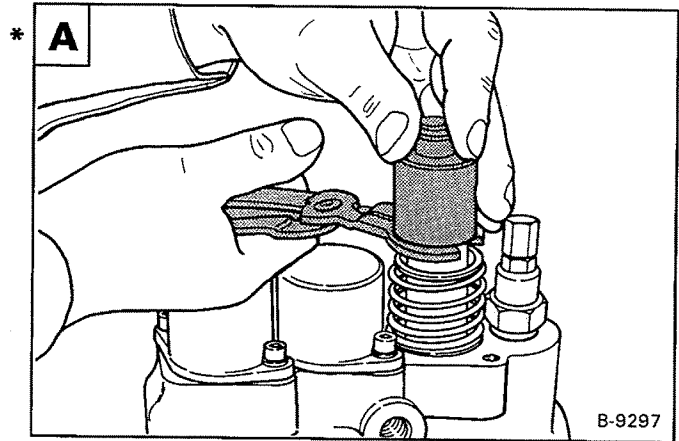

## **!** WARNING

Wear safety glasses to prevent eye injury when any of the following conditions exist:

- When fluids are under pressure.
- Flying debris or loose material is present.
- Engine is running.
- Tools are being used.

W-2019-1285

Assembly: Tighten the centering spring bolt to 90-100 in.-lbs. (10-11 Nm) torque.

**NOTE:** Carefully remove the centering spring bolt, because there is spring pressure.

Remove the spring caps, spring and adapter **D**.

Remove the spool and the front and rear O-rings from the bore.

Install the front O-ring in the groove. Install the valve spool into the valve from the rear of the valve. Push the spool into the valve just far enough so the rear O-ring can be installed.

Install the rear O-ring.

Push the spool back into the control valve until it is even with the rear machined surface of the valve.

Install the centering mechanism.

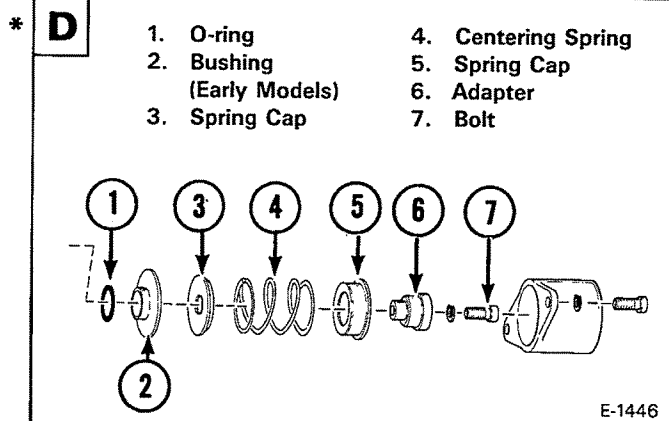

## HYDRAULIC PUMP (SINGLE STAGE)

### Checking the Output of the Hydraulic Pump

The tools listed will be needed to do the following procedure:

OEM-1238 — Hydraulic Tester  
MEL-10006 — Hydraulic Test Kit

**NOTE:** Make sure that all the air is removed from the system before beginning the test. Air in the system can give an inaccurate test.

Lift and block the loader (See Page 1–2 for the correct procedure).

Raise the operator cab (See Page 1–7 for the correct procedure).

Connect the jumper start switch (See Page 1–9 for the correct procedure).

Disconnect the outlet hose at the bottom of the hydraulic pump **A**.

Connect the INLET hose of the tester to the outlet of the pump **B**.

Connect the OUTLET of the tester to the hose which was removed from the hydraulic pump **B**.

**NOTE:** Make sure that the restrictor valve on the tester is fully open.

Start the engine and run at idle RPM. Make sure the tester is connected correctly. If no flow is indicated on the tester, the hoses are connected wrong. Increase the engine RPM to full RPM\*.

Warm the hydraulic fluid to 140°F (60°C) by turning the restrictor knob on the tester to about 1000 PSI (6895 kPa). DO NOT exceed system relief pressure.

Open the restrictor and record the free flow (GPM) at full RPM.

Use the right steering lever to put the auxiliary hydraulics into the detent position. Record the highest pressure and flow at full RPM.

The high pressure flow must be at least 80% of free flow.

$$\% = \frac{\text{HIGH PRESSURE FLOW (GPM-LPM)}}{\text{FREE FLOW (GPM-LPM)}} \times 100$$

A low percentage may indicate a failed hydraulic pump or it may be caused by air in the system. Make sure that all the air is removed from the system.

\*Refer to the specifications (Section 8) for system relief pressure and full RPM. The system relief pressure must be per specification before the test is run.

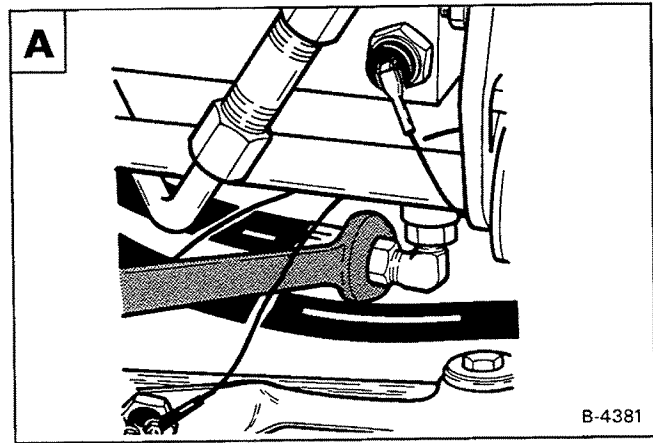

## IMPORTANT

Be careful when turning the flow control restrictor at the hydraulic tester. When the tester is connected this way there is no relief valve in the system. DO NOT close the flow restrictor, on the tester, all the way.

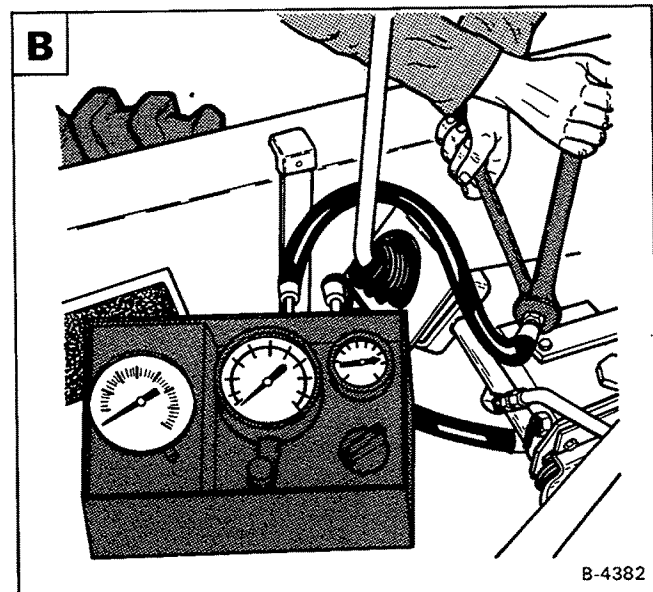



## HYDRAULIC PUMP (SINGLE STAGE) (Cont'd)

### Removal and Installation

# IMPORTANT

Always keep hydraulic and hydrostatic parts clean. Clean outside of all assemblies before beginning repairs. Use plugs and caps to cover open ports. Dirt can quickly damage the system.

I-2021-0284

Remove the port block from the hydraulic pump (See Page 2-51 for the correct procedure).

Disconnect the outlet hose from the pump **A**.

Remove the two mounting bolts **B**.

Installation: Tighten the bolts to 25 ft.-lbs. (34 Nm) torque.

Remove the hydraulic pump and the O-ring **C**.

### Disassembly and Assembly

Put the pump in a vise.

Make a mark across the body for correct assembly.

Remove the bolts from the pump **D**.

Assembly: Tighten the bolts to 23 ft.-lbs. (31 Nm) torque.

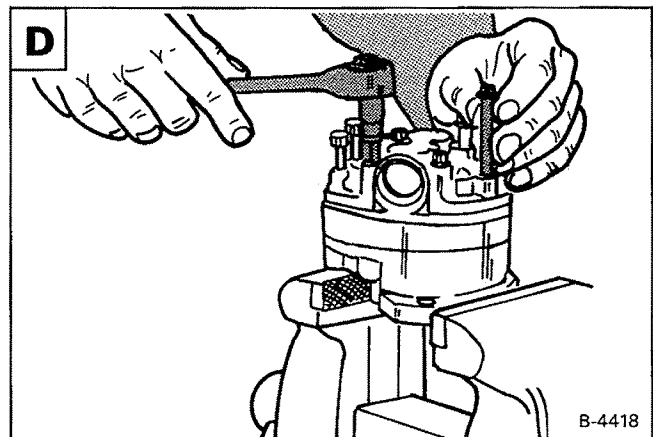
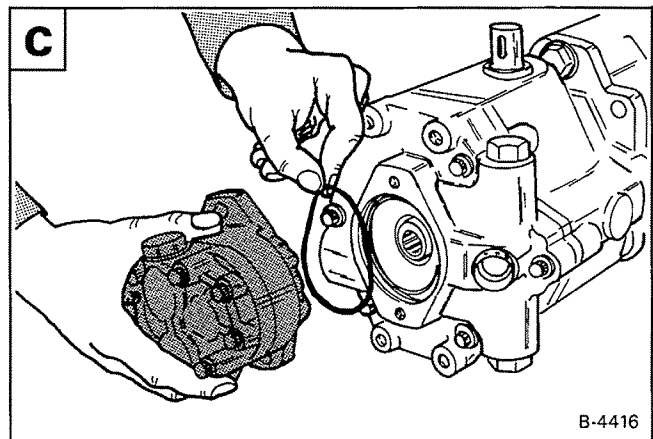
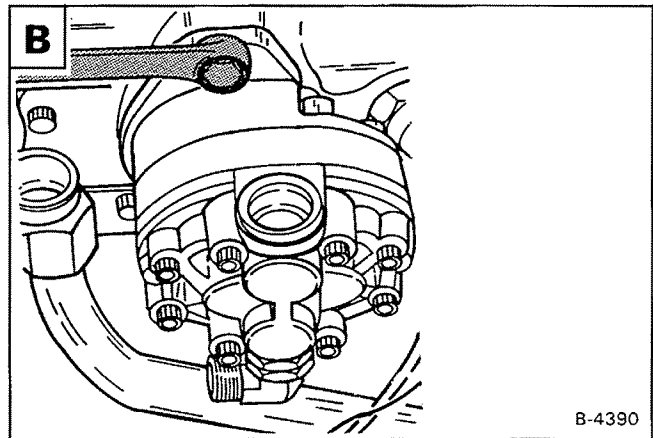
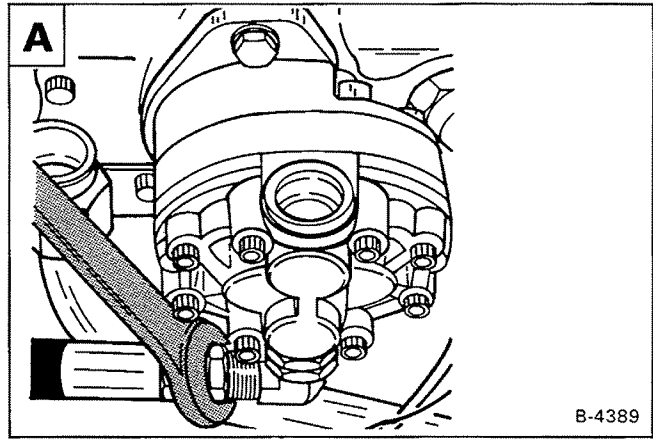

HYDRAULIC PUMP (SINGLE STAGE) (Cont'd)

Remove the pump housing **A**.

Remove the O-ring.

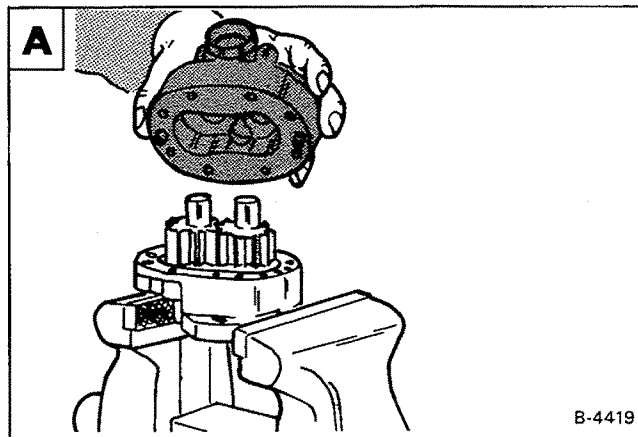

Remove the idler and drive gears **B**.

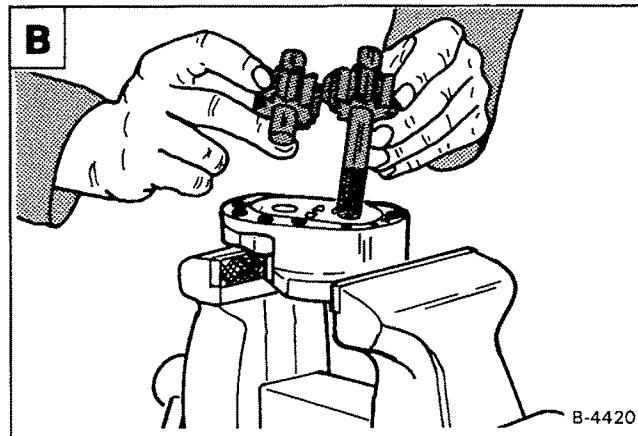

Remove the wear plate **C**.

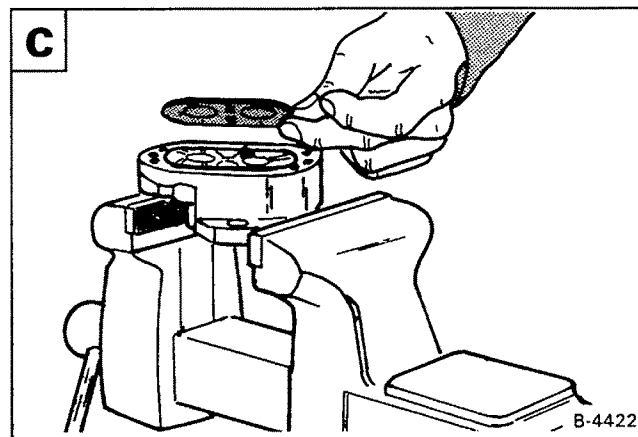

Remove the spring and steel ball from the pump housing **D**.

**IMPORTANT**

Make sure to mark the port where the spring and steel ball are removed. If the ball and spring are installed in the wrong port, damage will result to the complete hydrostatic pumps. Only one ball and spring must be installed on the high pressure side of the pump or the lower port as it is attached to the hydrostatic pumps.

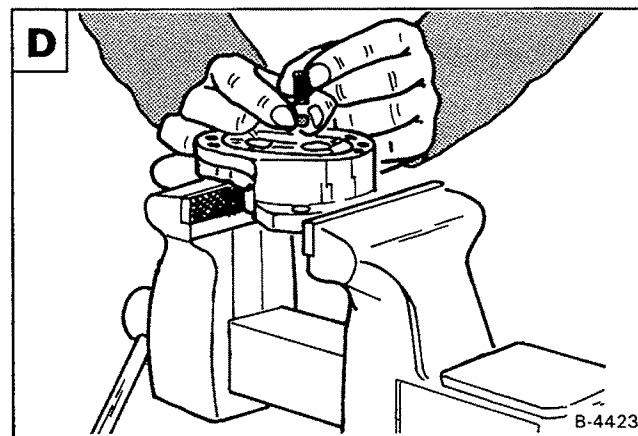

## HYDRAULIC PUMP (SINGLE STAGE) (Cont'd)

Remove the back-up gasket and diaphragm seal from the housing **A**.

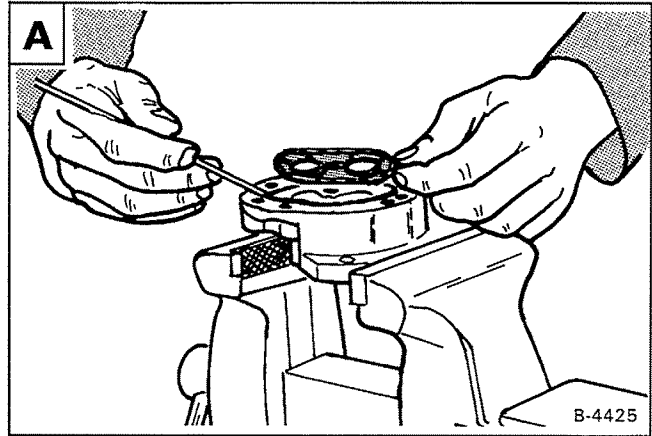

### Inspection

Clean and dry the parts.

Inspect the drive gears **B**.

Check the bearing points and seal area for rough surface and wear.

If the shaft measures less than 0.685" (17,4 mm) at the bearing point or the gear width is less than 0.924" (23,5 mm), the gears must be replaced.

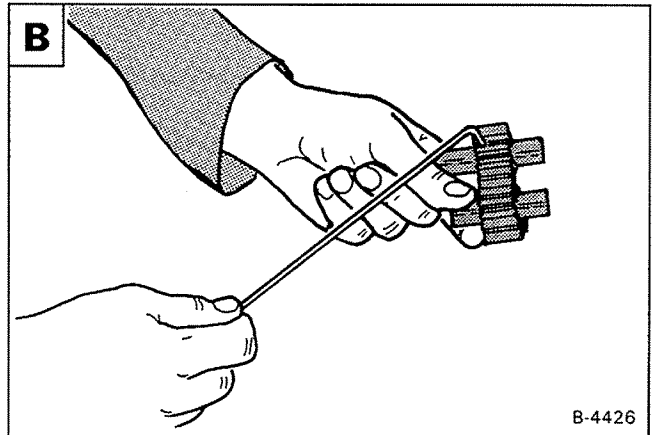

Check the I.D. of the bearings in the front and back housing **C**.

If the bearings are more than 0.691" (17,5 mm), the housing must be replaced (bearings are not available as a separate items).

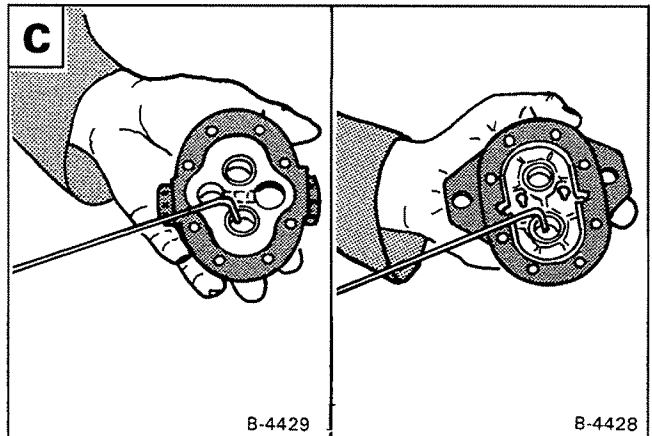

Oil grooves in the bearings at both housings must be in alignment with the dowel pin hole and 180° apart. This put the oil grooves closest to the correct dowel pin **D**.

Check the body gear area for wear **D**.

Replace as needed.

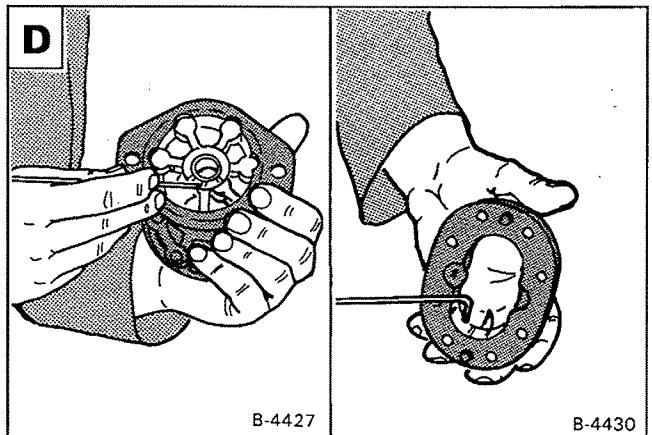

## HYDRAULIC PUMP (DOUBLE STAGE)

The hydraulic pump is a two stage (double gear) pump, each section of the pump must be checked separately.

The tools listed will be needed to do the following procedure:

- OEM-1238 — Hydraulic Tester
- MEL-10006 — Hydraulic Test Kit

### Checking the Output of the Hydraulic Pump

**NOTE:** Make sure that all the air is removed from the system before beginning the test. Air in the system can give an inaccurate test.

Lift and block the loader (See Page 1–2 for the correct procedure).

Raise the operator cab (See Page 1–7 for the correct procedure).

Connect the jumper start switch (See Page 1–9 for the correct procedure).

**Small Section of the Pump Only:** Disconnect the outlet hose from the pump **A**. Connect the inlet hose of the tester to the outlet of the pump **A**. Connect the outlet of the tester to the hose which was removed from the pump **A**. Disconnect the hose which goes to the port block (at the hydraulic pump). Put plugs in the hose and the fitting on the pump.

Disconnect the hose which goes to the port block (on the hydraulic pump). Plug the hose and the fitting on the hydraulic pump.

**Large Section of the Pump Only:** Disconnect the outlet hose from the pump **B**. Connect the inlet hose of the tester to the outlet of the pump **B**. Connect the outlet of the tester to the hose which was removed **B**.

**NOTE:** Make sure that the restrictor valve on the tester is fully open.

Start the engine and run at low RPM. Make sure that the tester is connected correctly. If no flow is indicated on the tester, the hoses are connected wrong.

Increase the engine speed to full RPM\*. Warm the hydraulic fluid to 140°F (60°C) by turning the restrictor knob on the tester to about 1000 PSI (6895 kPa). Do not exceed system relief pressure.

Open the restrictor on the tester and record the free flow at full RPM.

**Small Section of the Pump Only:** Turn the restrictor knob so there is about 500 - 600 PSI (3448 - 4137 kPa). Record the highest pressure (PSI) and flow (GPM) at full RPM.

**Large Section of the Pump Only:** Use the right steering lever to engage the auxiliary hydraulics. Record the highest pressure and flow at full RPM.

The highest pressure flow must be at least 80% of free flow.

$$\% = \frac{\text{HIGH PRESSURE FLOW (GPM-LPM)}}{\text{FREE FLOW (GPM-LPM)}} \times 100$$

A low percentage may indicate a failed hydraulic pump, or it may be caused by air in the system. Make sure that all the air is removed from the system.

\*Refer to the Specifications (Section 8) for system relief pressure and full RPM. The system relief pressure must be per specifications before test is run.

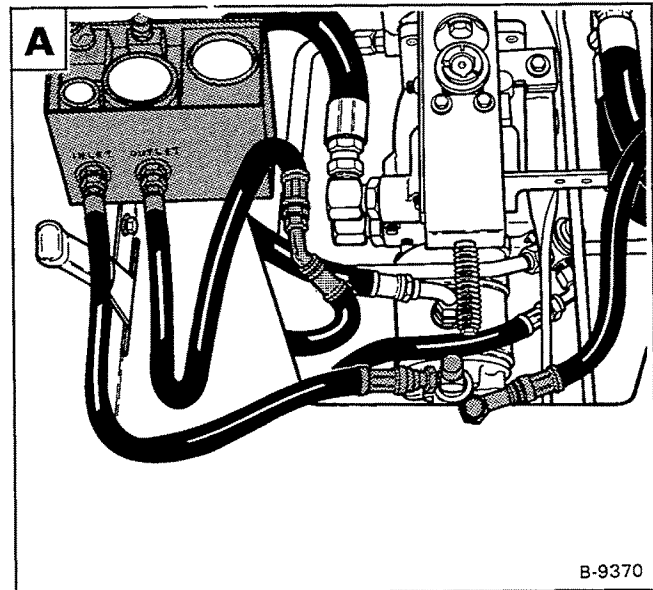

## IMPORTANT

Be careful when turning the flow control restrictor at the hydraulic tester. When the tester is connected this way there is no relief valve in the system. DO NOT close the flow restrictor, on the tester, all the way.

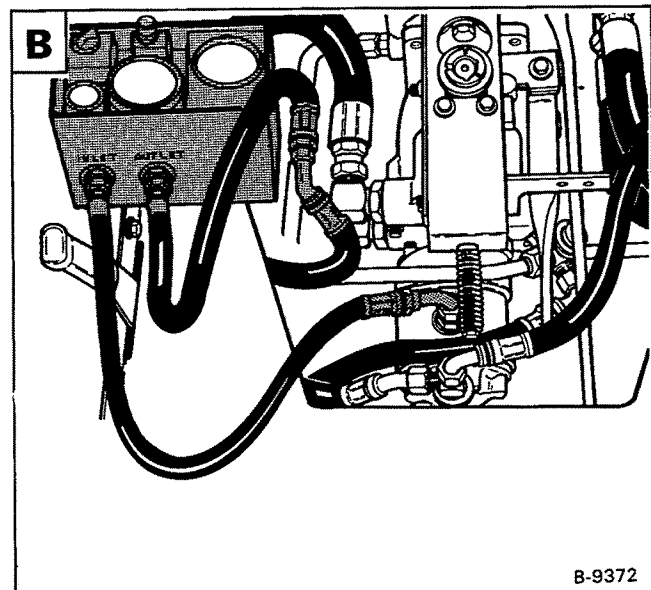

## HYDRAULIC PUMP (DOUBLE STAGE) (Cont'd)

### Removal and Installation

Lift and block the loader (See Page 1-2 for the correct procedure).

Raise the lift arms and have a second person install a lift arm stop (See Page 1-4 for the correct procedure).

Stop the engine. Raise the operator cab (See Page 1-7 for the correct procedure).

# IMPORTANT

Always keep hydraulic and hydrostatic parts clean. Clean outside of all assemblies before beginning repairs. Use plugs and caps to cover open ports. Dirt can quickly damage the system.

I-2021-0284

Disconnect the charge pressure hose at the front of the pump **A**.

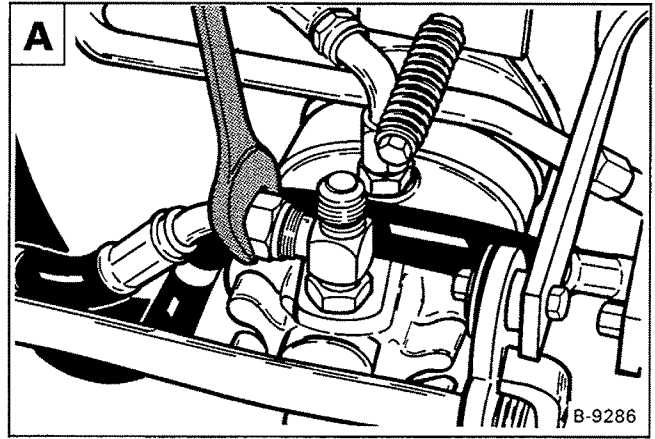

Disconnect the hose at the charge pressure sender **B**.

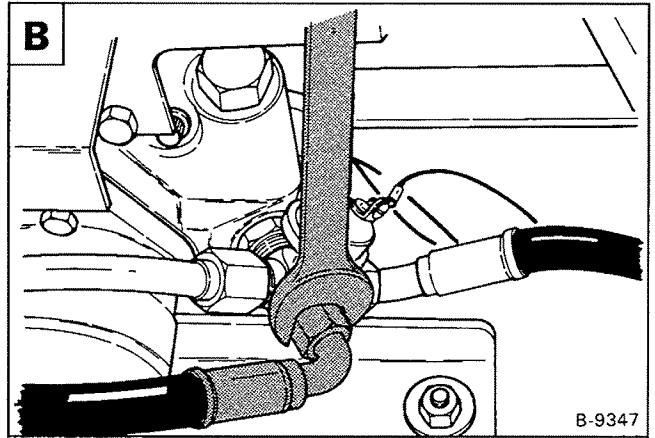

Disconnect the charge tubeline at the charge pressure sender **C**.

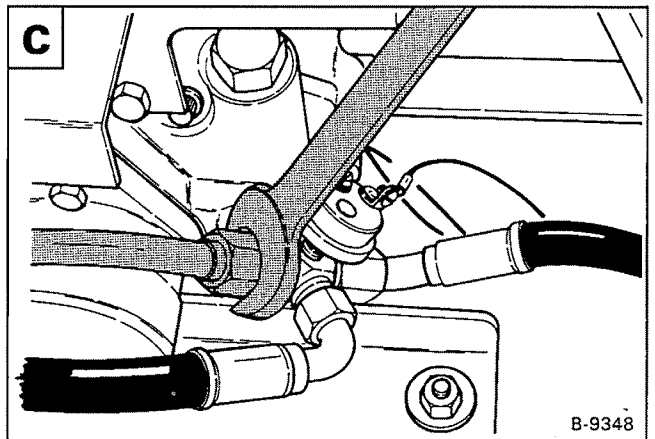

Disconnect the charge pressure tubeline from the hydrostatic pump **D**.

Remove the tubeline.

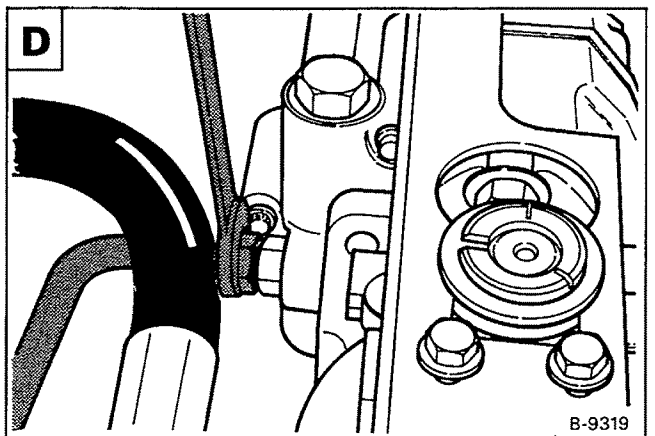

**HYDRAULIC PUMP (DOUBLE STAGE) (Cont'd)**

Disconnect the hose from the rear section of the pump **A**.

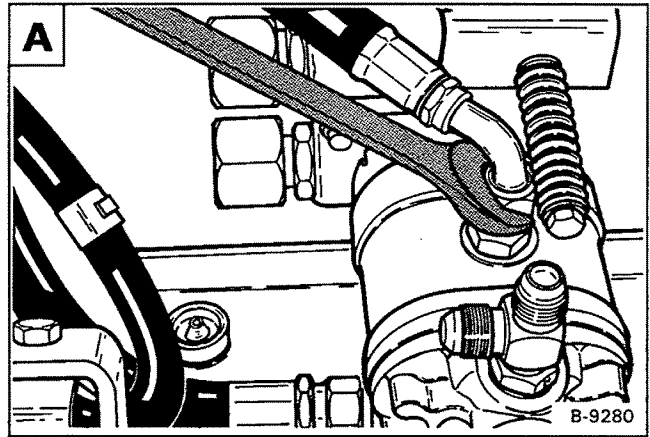

Remove the tee fitting at the front section **B**.

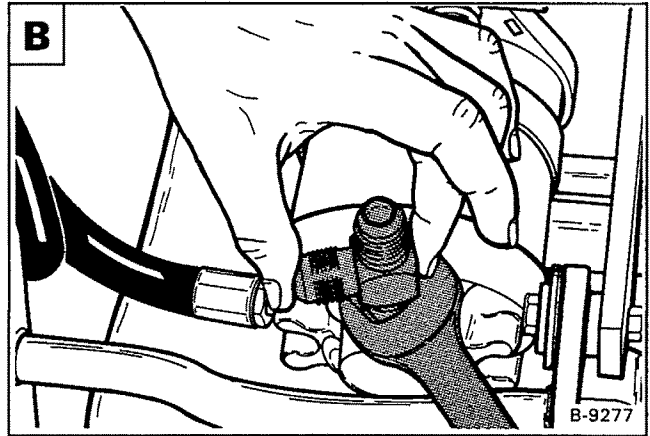

Disconnect the inlet hose at the bottom fitting of the hydraulic pump **C**.

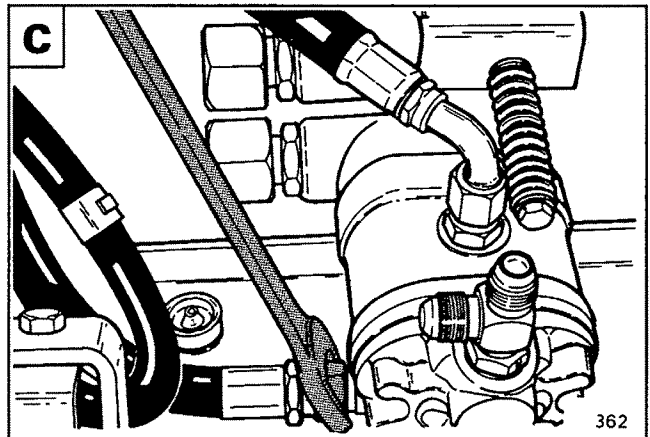

Loosen the clamp at the inlet hose **D**.

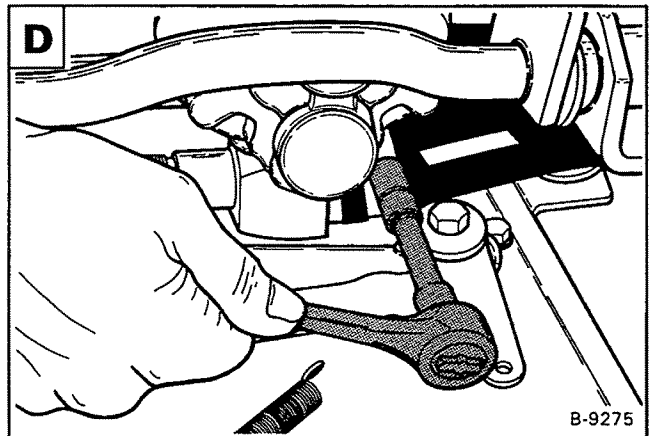

## HYDRAULIC PUMP (DOUBLE STAGE) (Cont'd)

Remove the mounting bolts from the pump flange **A**.

Installation: Tighten the bolts to 25-28 ft.-lbs. (34-38 Nm) torque.

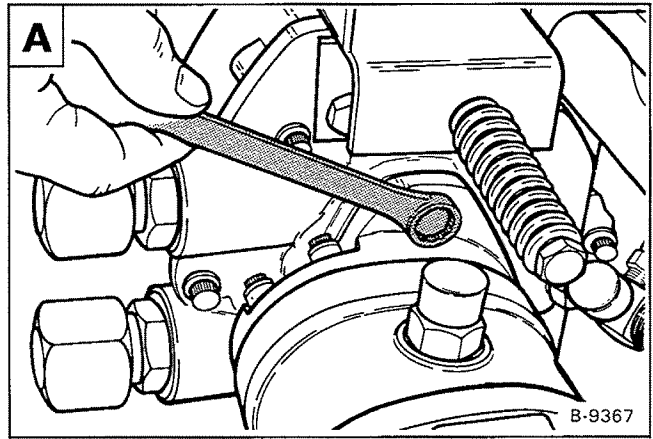

Turn the pump so the inlet fitting at the bottom is to the side and slide the pump from the hydrostatic pump **B**.

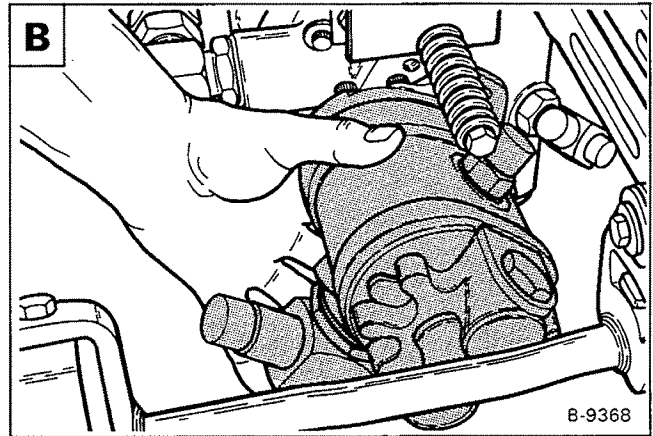

## Disassembly and Assembly

Put the pump in the vise.

Put a mark across the body of the pump for correct assembly.

Loosen the through bolts **C**.

Assembly: Tighten the bolts to 25-28 ft.-lbs. (34-38 Nm) torque.

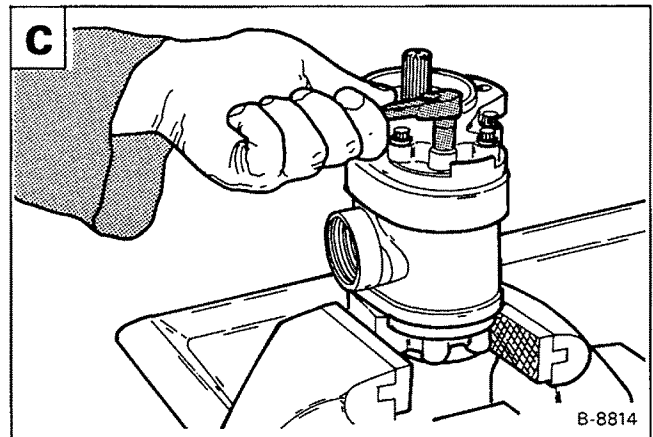

Remove the bolts from the pump **D**.

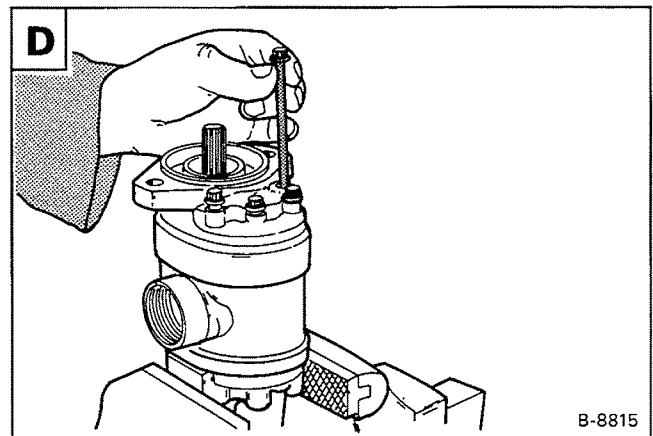

HYDRAULIC PUMP (DOUBLE STAGE) (Cont'd)

Separate the pump body from the end plate **A**.

Remove the O-ring.

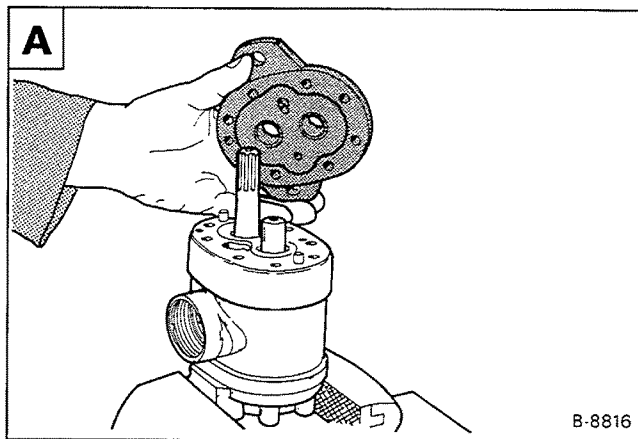

Remove the pressure plate at the gears **B**.

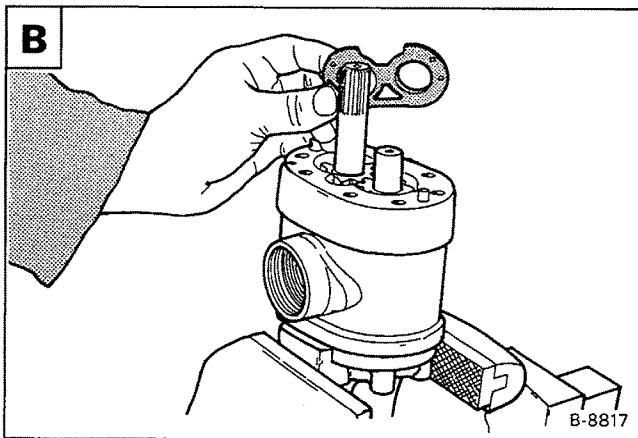

Remove the large section from the pump **C**.

Remove the O-ring.

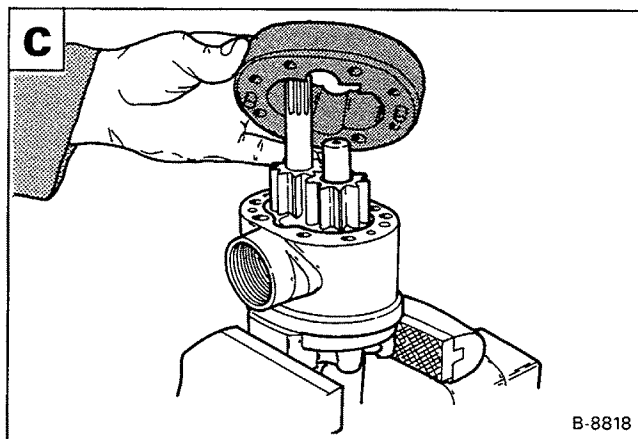

Remove the large idler gear **D**.

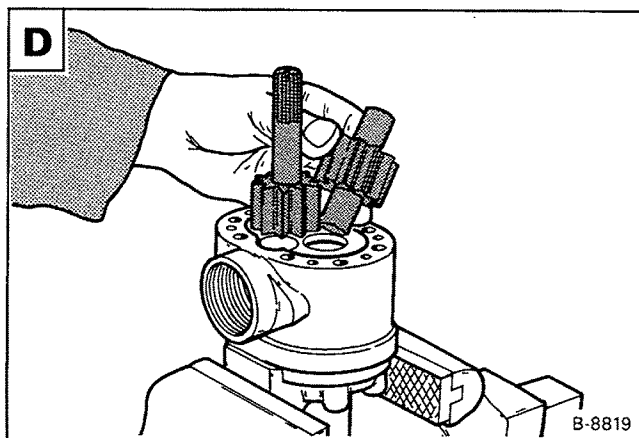



## HYDRAULIC PUMP (DOUBLE STAGE) (Cont'd)

Remove the pump body with the drive gear and shaft.

Assembly: Make sure the round key (Item 1) is in position and engages with the small drive gear slot **A**.

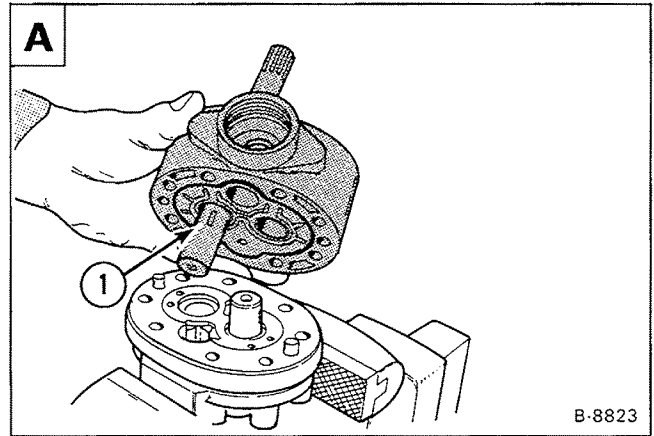

Remove the pressure plate from the small gears **B**.

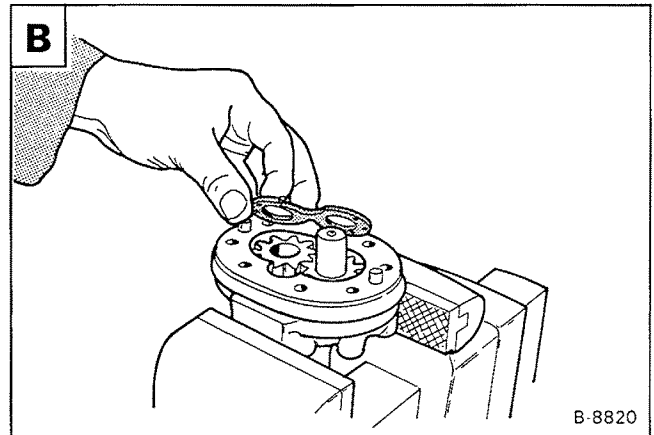

Remove the small section of the pump **C**.

Remove the O-ring.

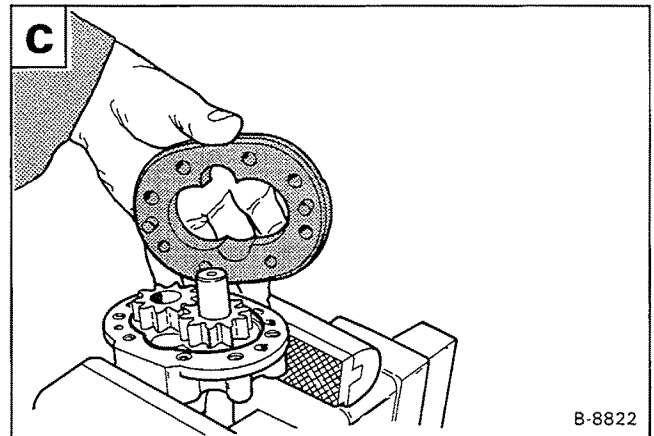

Remove the small drive and idler gear **D**.

### Inspection

Clean and dry all the parts.

Inspect both drive gears and idler gears at bearing points and seal area for rough surfaces and wear.

Check the bushings in the end housings.

Check the pressure plates for wear.

Always use new O-rings when assembling the hydraulic pump.

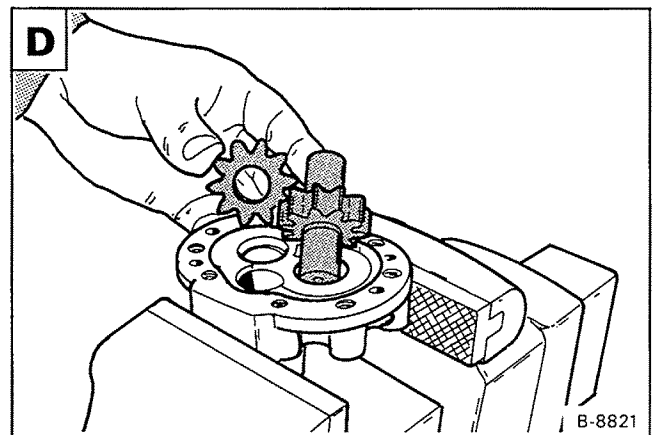

**BUCKET POSITION VALVE (S/N 15001 & Above)**

**Removal and Installation**

Stop the engine. Operate the hydraulic controls to release the hydraulic pressure.

Open the rear door.

Disconnect all the tubelines at the bucket position valve **A**.

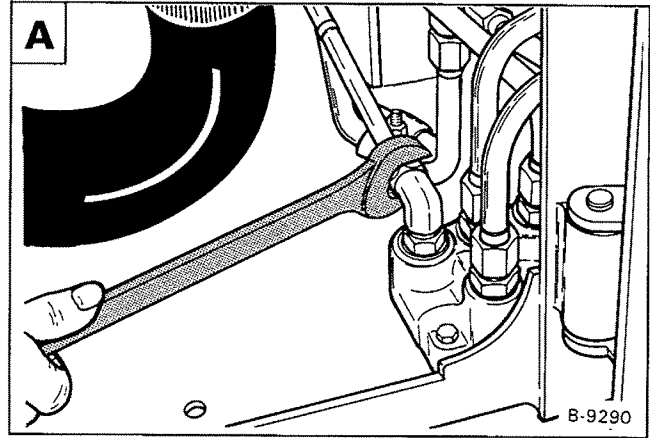

Remove the bolts and nuts and remove the bucket position valve **B**.

Installation: Put Loctite on the treads of the tubeline fittings before tightening.

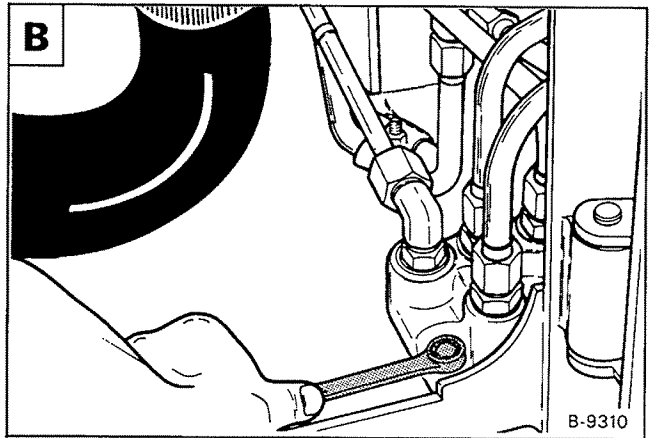

**Disassembly and Assembly**

**NOTE:** Make sure to mark the plugs and valves for correct assembly.

Remove the plug, O-ring, spring and spool **C**.

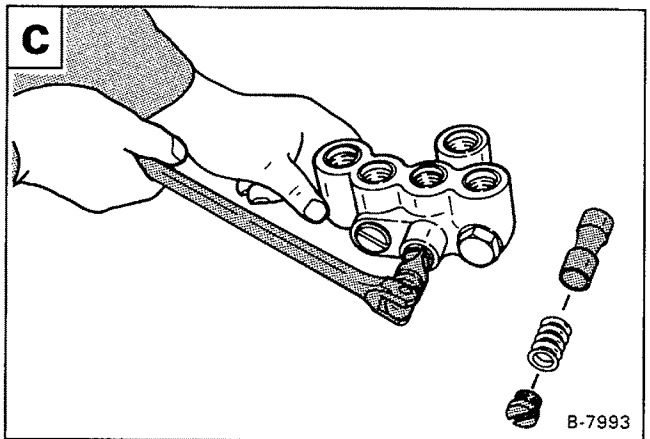

On the other side, remove the plug and O-ring **D**.

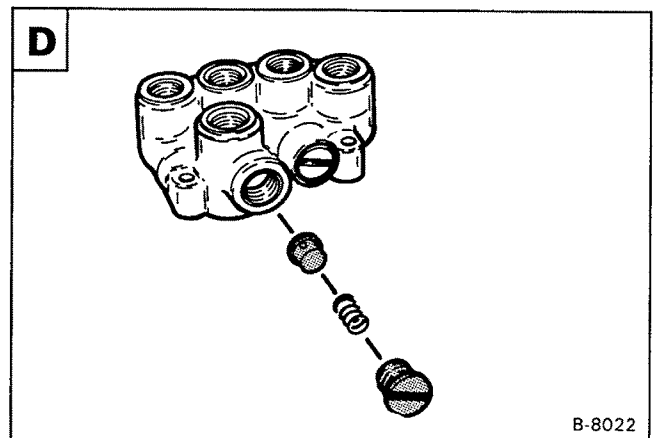

**BUCKET POSITION VALVE (S/N 15001 & Above)**

Remove the plug, O-ring , spring and spool **A**.

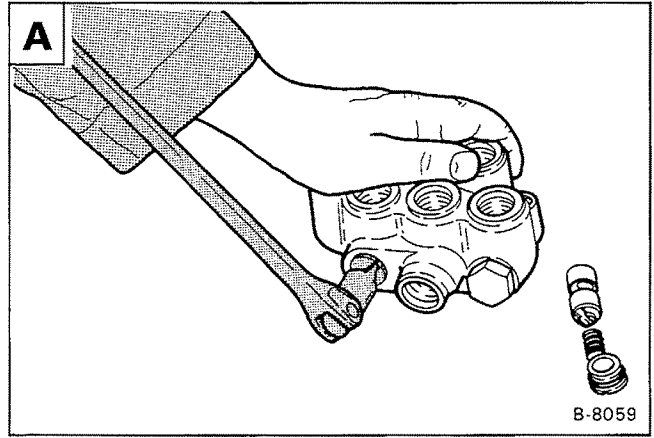

On the other side, remove the plug and O-ring **B**.

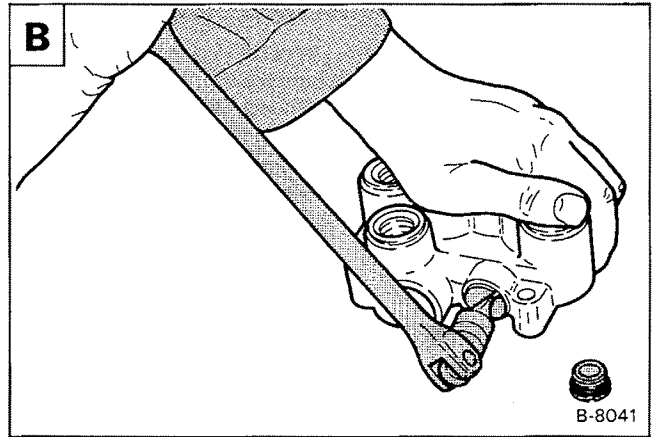

Remove the flow divider plug and O-rings **C**.

Clean and check all the parts for wear, replace as needed.

Always use new O-rings and back-up washers when assembling the bucket position valve.

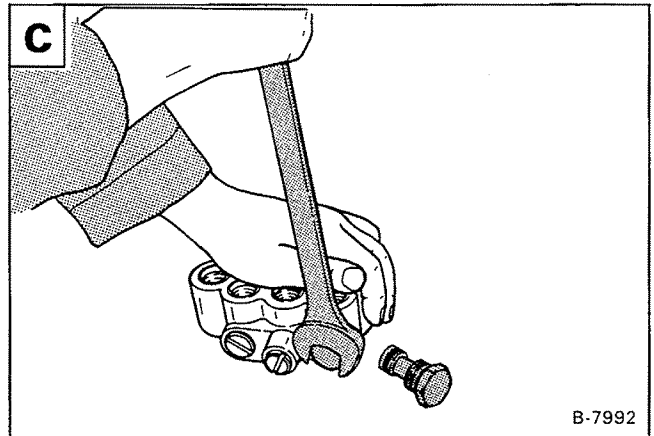

Copyright © 2009 Caterpillar Inc. All rights reserved. This document is the property of Caterpillar Inc. and is not to be distributed outside the company without the express written permission of Caterpillar Inc.

**PORT BLOCK (S/N 14999 & Below)**

**40 Micron Filter (Bronze)**

The tool listed will be needed to do the following procedure:

MEL-1177 — Filter Removal Tool

Replace the bronze (40 micron) filter every 500 hours of loader operation.

**IMPORTANT**

Always keep hydraulic and hydrostatic parts clean. Clean outside of all assemblies before beginning repairs. Use plugs and caps to cover open ports. Dirt can quickly damage the system.

I-2021-0284

Raise the operator cab.

Disconnect the hose at the fitting **A**.

Remove the fitting from the port block **B**.

Install the filter removal tool on the filter **C**.

Remove the filter, spring and sleeve from the port block **D**.

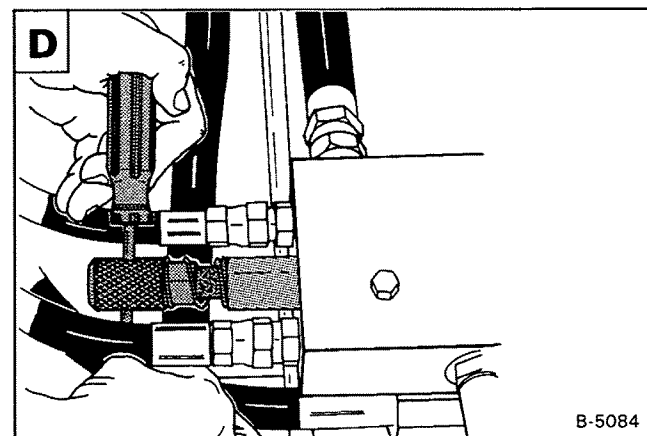
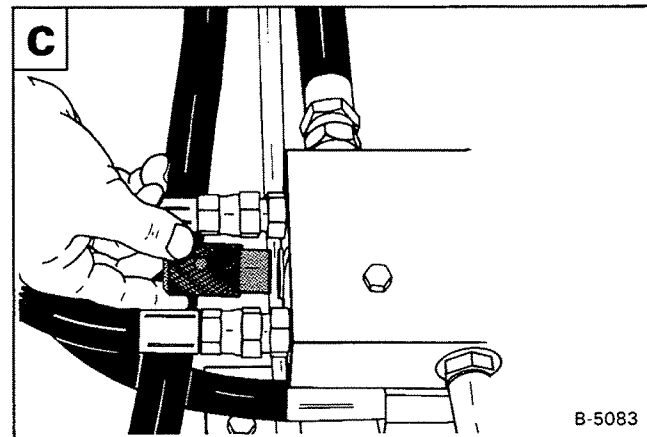
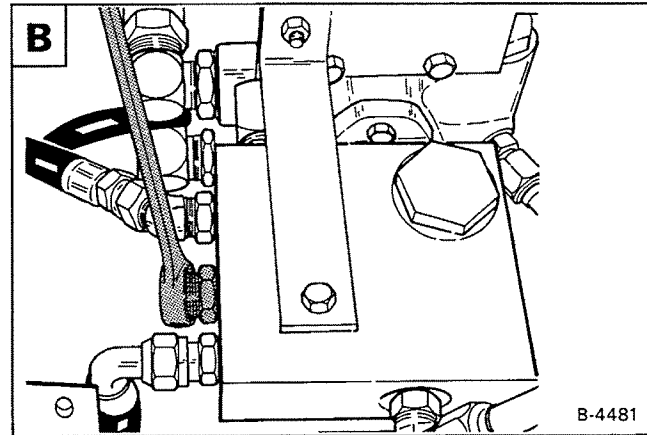
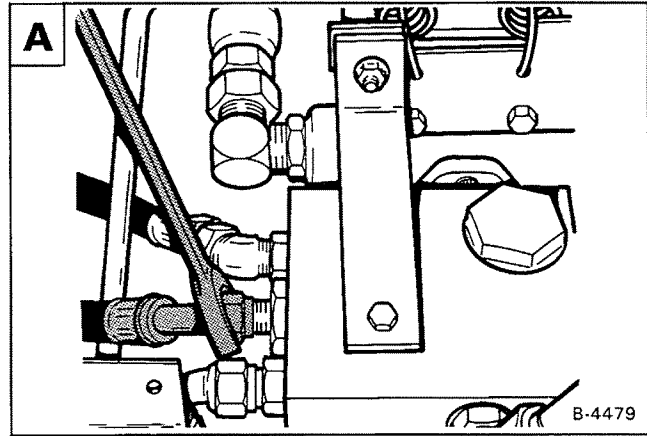

### PORT BLOCK (S/N 14999 & Below) (Cont'd)

Remove the filter removal tool from the filter **A**.

**NOTE:** DO NOT remove the sleeve before removing the bronze filter from the port block. Particles trapped by the filter may drop and enter the system. Always check the port block for debris and clean the bore.

Clean the filter and sleeve in clean solvent, use air pressure to dry them.

Install the spring, filter and sleeve on the tool **A**.

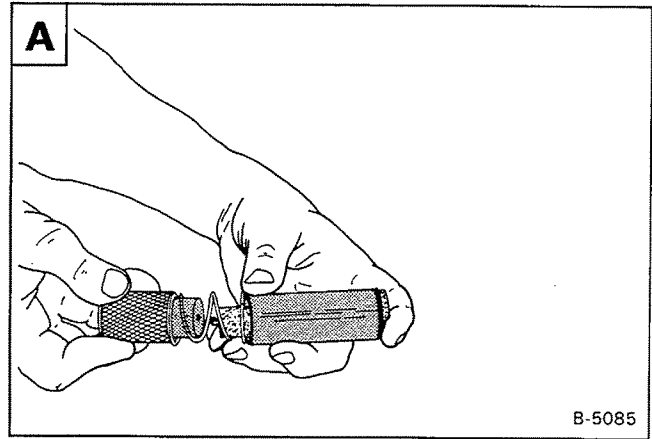

Install the assembly into the port block **B**.

Remove the tool. Install the fitting and connect the hose.

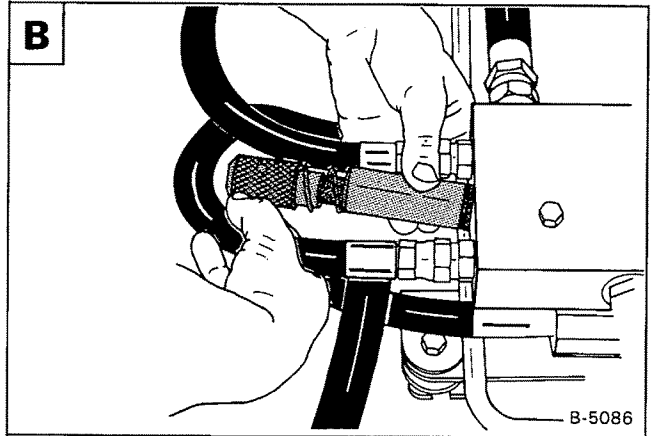

### Neutral By-Pass Valve

Raise the operator cab.

Disconnect the hose from the fitting **C**.

Remove the fitting.

Remove the spring and by-pass poppet from the port block **C**.

Clean the parts. Check the valve seat in the port block. Replace the parts as needed.

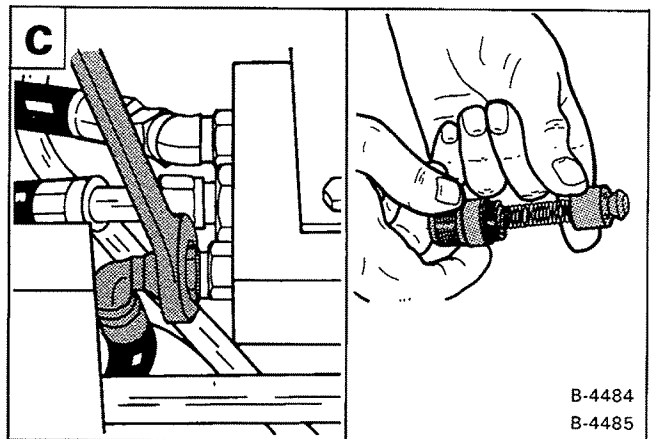

### Removal and Installation

Raise the operator cab.

Remove the hoses from the port block **D**.

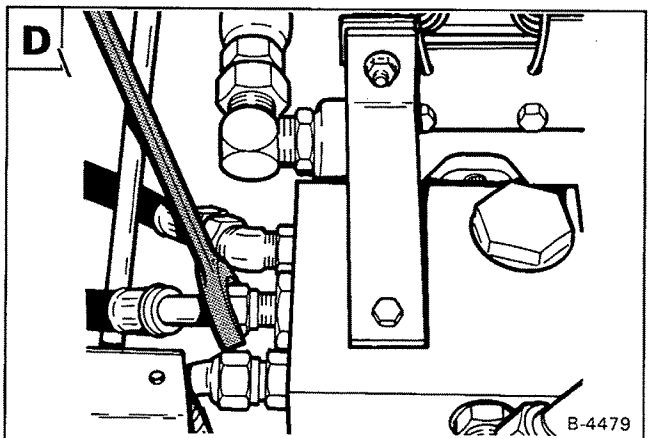

PORT BLOCK (S/N 14999 & Below) (Cont'd)

Disconnect the charge tubelines at the front of the port block **A** **B**.

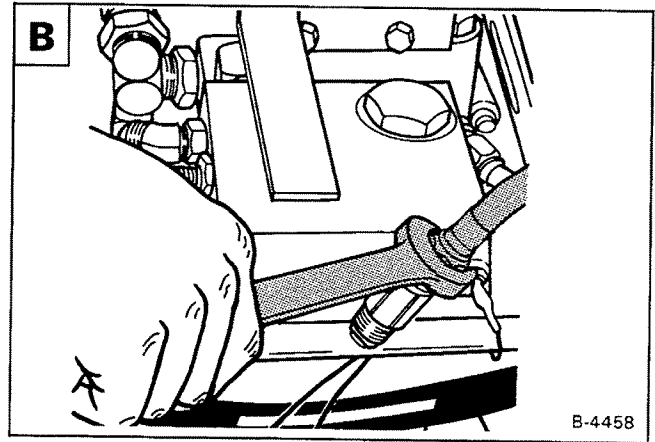
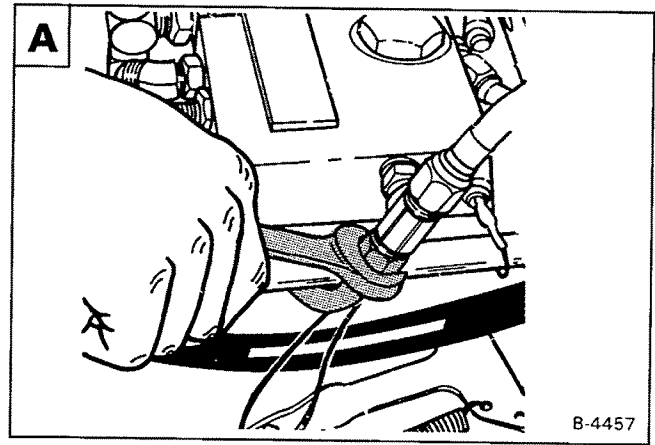

Disconnect the charge tubeline at the rear of the hydrostatic pump **C**.

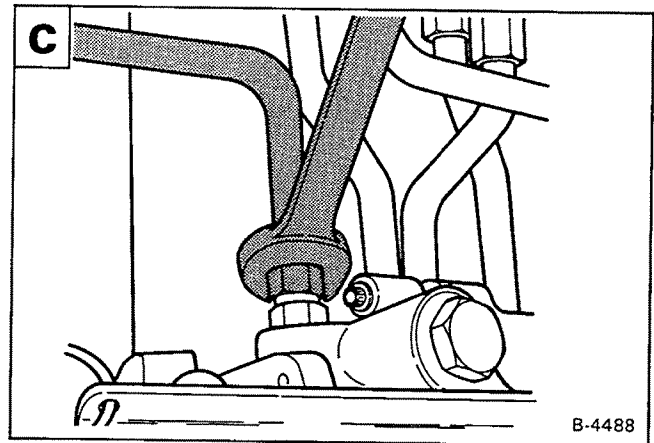

Disconnect the charge tubeline at the front of the hydrostatic pump **D**.

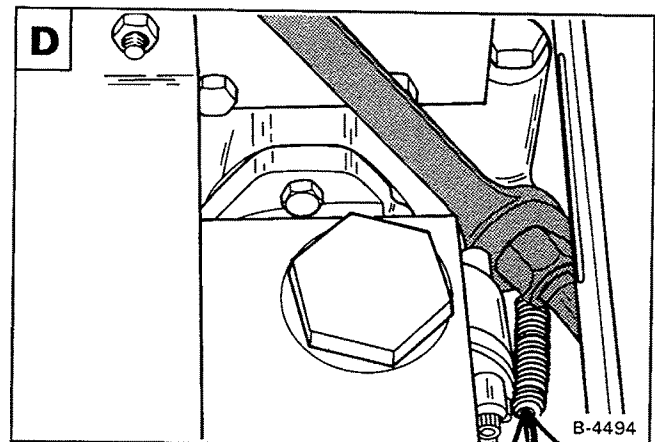

## PORT BLOCK (S/N 14999 & Below) (Cont'd)

Disconnect the tubeline which goes to the hydraulic/hydrostatic reservoir **A**.

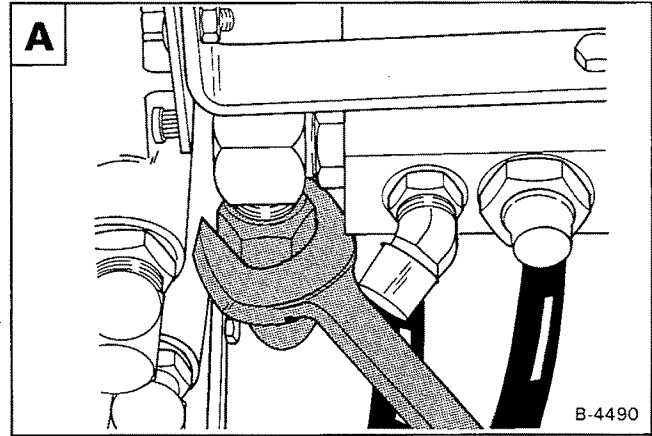

Remove the bracket from the port block **B**.

Installation: Tighten the bolt to 25-28 ft.-lbs. (34-38 Nm) torque.

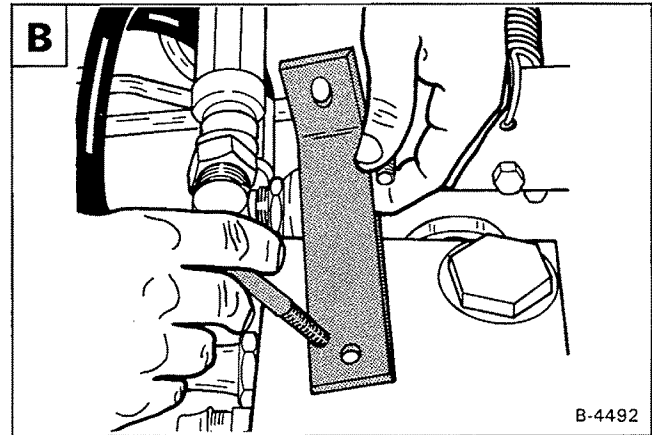

Remove the large bolt from the port block and remove the port block from the hydraulic pump **C**.

Clean all the parts in solvent. Use air pressure to dry them.

Always use NEW O-rings when assembling the port block.

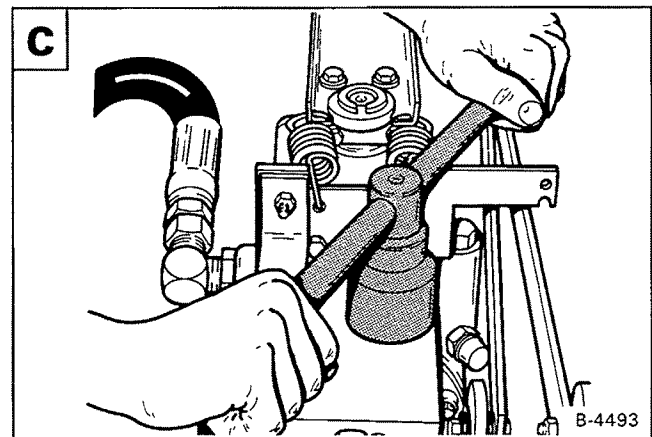

**PORT BLOCK (S/N 15001 & Above)**

**Removal and Installation**

Raise the operator cab.

Remove the front and side panels (See Page 3—9 for the correct procedure).

Disconnect the wire at the temperature switch **A**.

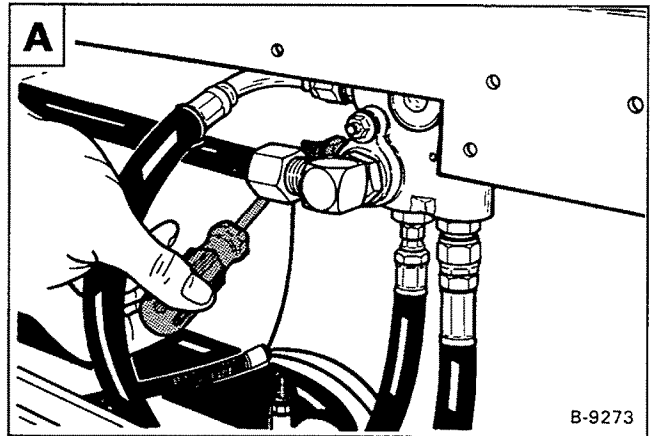

Disconnect the fitting at the tubeline from the reservoir **B**.

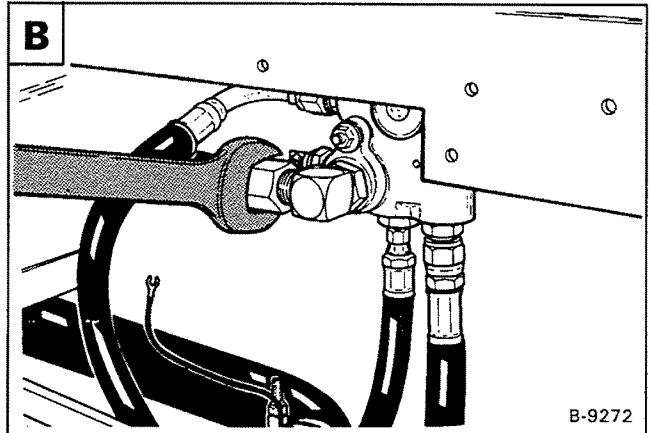

Disconnect both hydraulic hoses **C**.

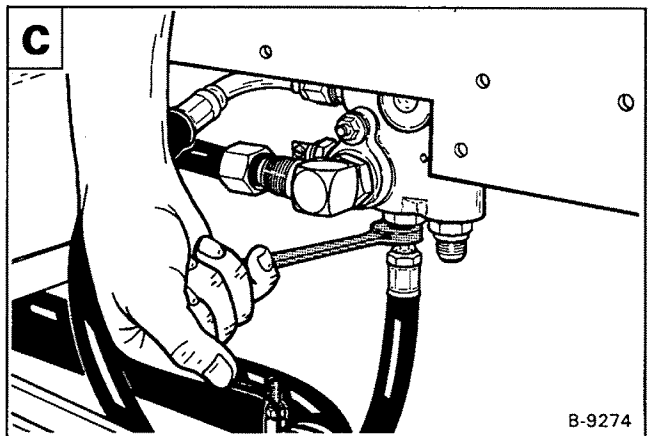

Remove the mounting bolt.

Remove the port block from the loader **D**.

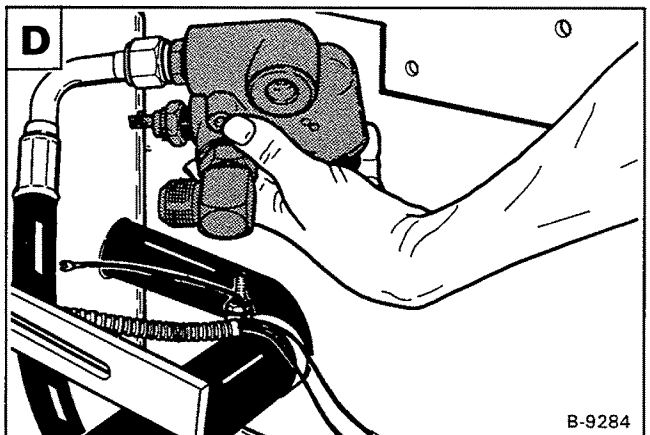



PORT BLOCK (S/N 15001 & Above) (Cont'd)

Charge By-Pass

Remove the fitting **A**.

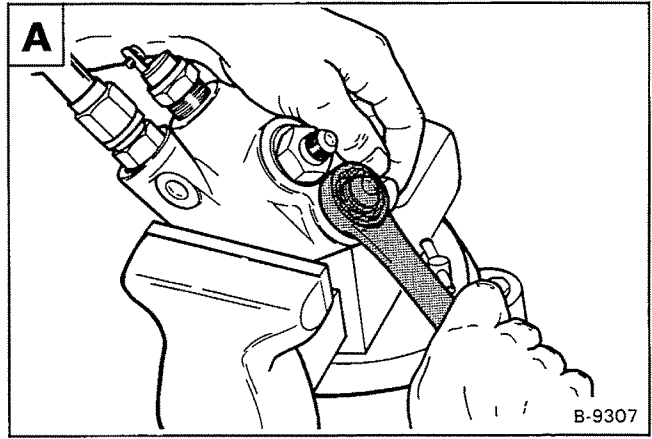

Remove the poppet and spring **B**.

Install a NEW O-ring before installing the fitting.

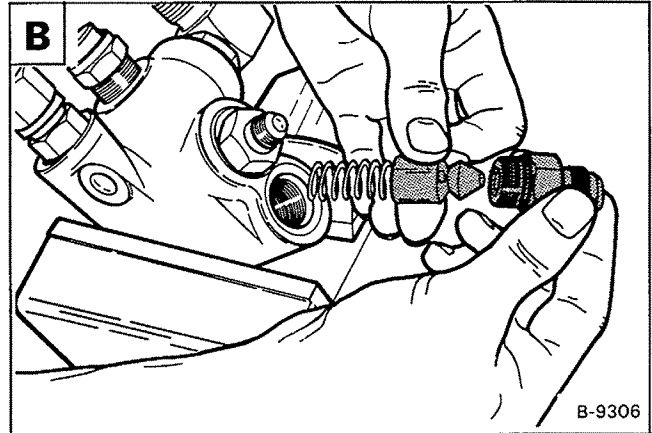

Cold Oil By-Pass

Remove the fitting **C**.

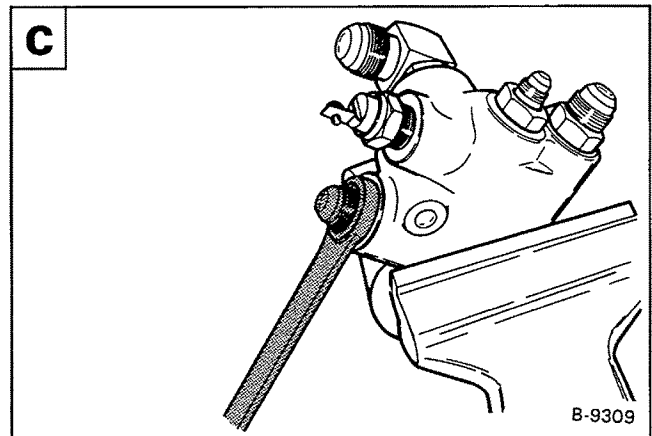

Remove the poppet and spring **D**.

Install a NEW O-ring before installing the fitting.

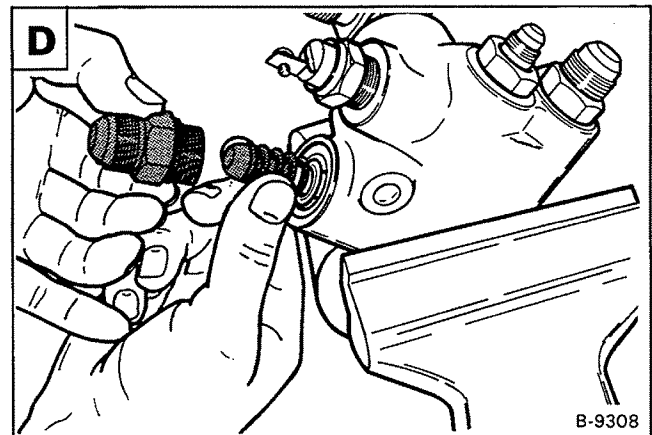

Page 425 - BURNDY/VALVE/110 - PRINTED BY BEN LUCK CO. - EXPRINT.exe (V2.48.3 9/25/2008)

## HYDRAULIC FLUID FILTER HOUSING (S/N 15001 & Above)

### Removal and Installation

Raise the operator cab (See Page 1-7 for the correct procedure).

Disconnect and remove the throttle rod linkage at the throttle lever.

Disconnect the tubeline at the filter housing **A**.

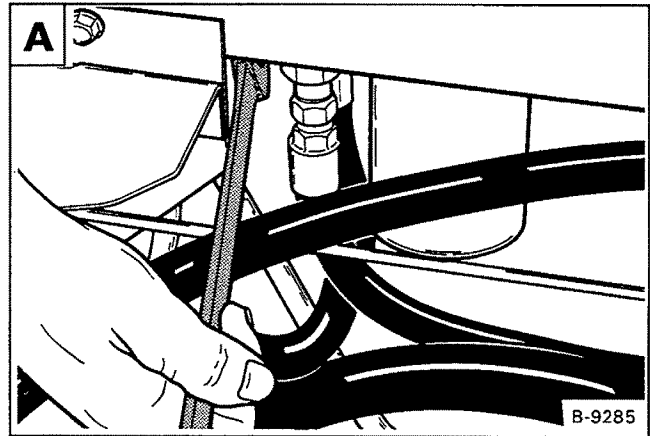

Remove the mounting bolt and nut **B**.

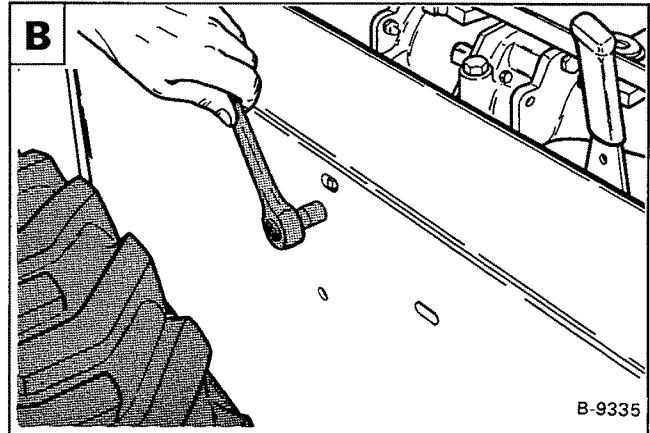

Pull the filter housing away from the loader frame.

Disconnect the hoses from the filter housing **C**.

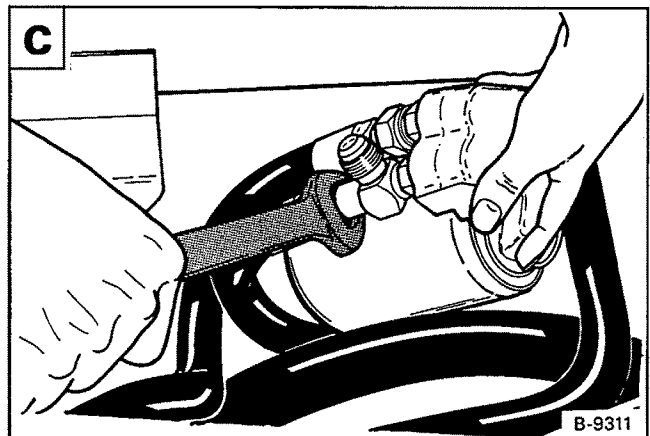

### By-Pass Valve

Remove the plug, spring and poppet **D**.

Clean all the parts.

Check the poppet and seat for scratches.

Replace the parts as needed.

Always use a NEW O-ring when installing the by-pass valve.

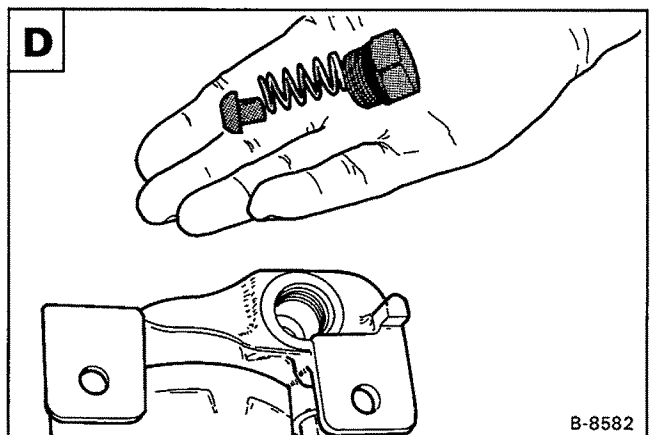



**HYDRAULIC/HYDROSTATIC RESERVOIR**  
(S/N 21514 & Below) (Cont'd)

Loosen the clamp at the outlet hose for the reservoir **A**.

**NOTE:** It may be easier to disconnect and remove the hose from the reservoir at the hydraulic pump. Turn the hydraulic pump about 90° so the hose comes off the inlet fitting at the hydraulic pump.

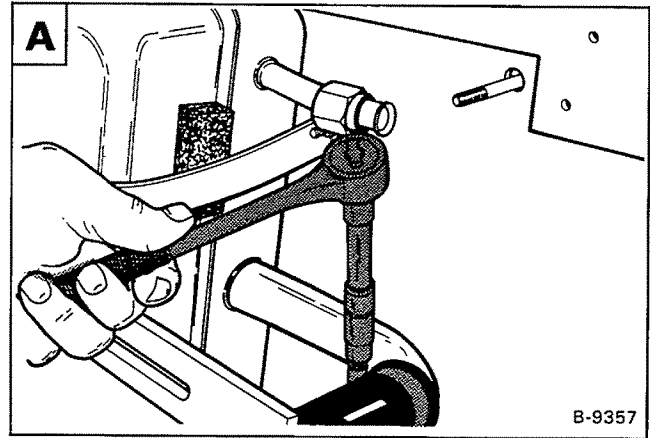

Remove the bolts at the holding strap **B**.

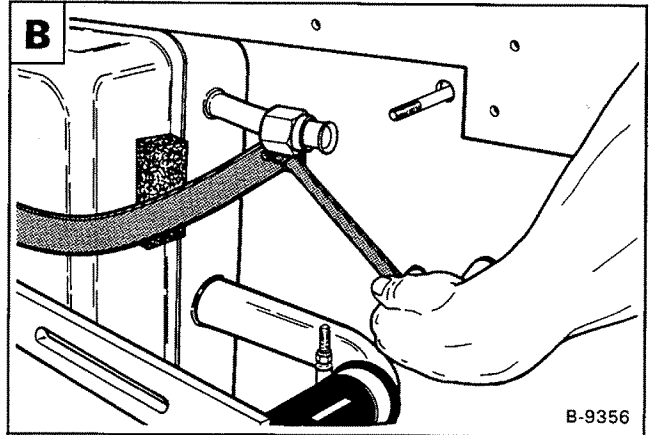

Slide the reservoir forward and to the side and remove it from the loader **C**.

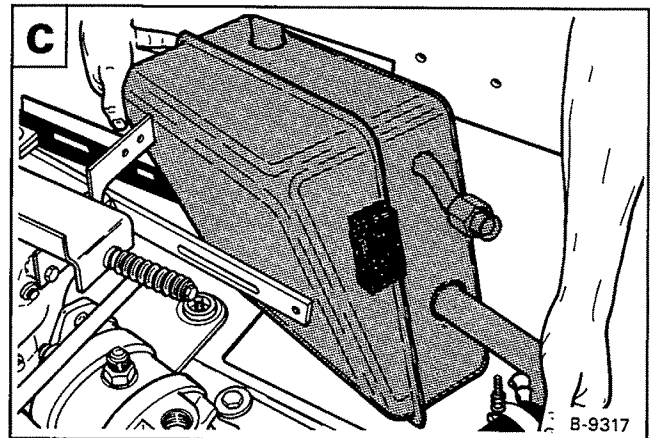

## HYDRAULIC CONTROLS PEDALS (S/N 14999 & Below)

### Removal and Installation

Disconnect the linkage at the pedal **A**.

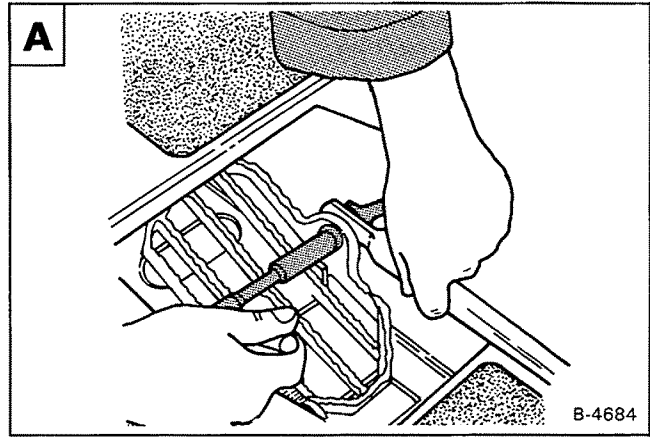

Remove the hair pins at the pivot pins **B**.

Remove the pedal from the bracket.

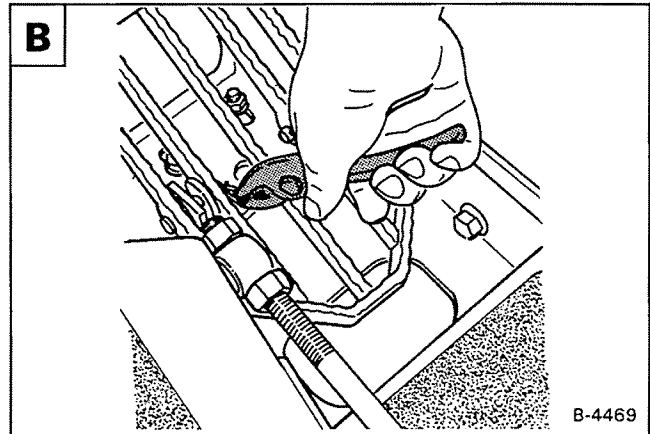

Remove the bushing from the pedal, using a vise, install the new bushing in the pedal **C**.

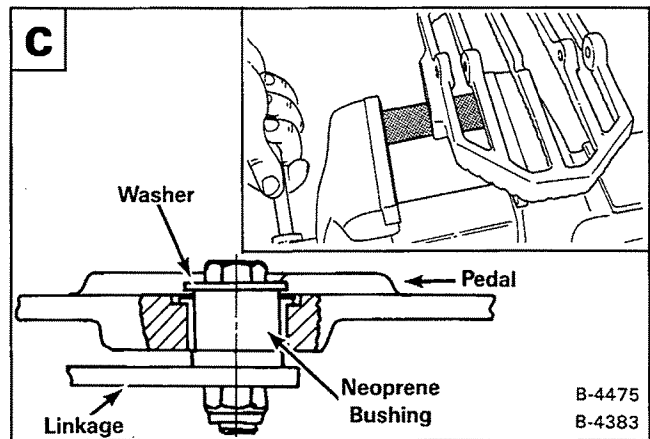

### Adjustment

Loosen the nuts at the mounting bracket **D**.

Slide the mounting bracket backward or forward until there is about 1-1/2" (38 mm) under the rear edge of the pedal.

Tighten the nuts to 25-28 ft.-lbs. (34-38 Nm) torque.

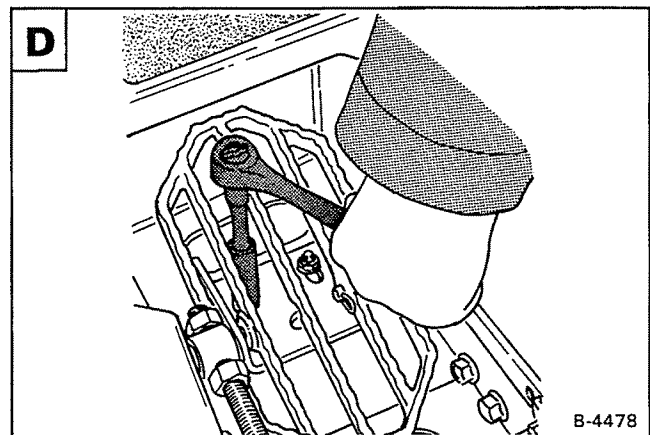

Copyright © 2008 Caterpillar Inc. All rights reserved. Printed in the U.S.A. 14999 & Below

## HYDRAULIC CONTROL PEDALS (S/N 15001 & Above)

### Removal and Installation

Remove the bolt and nut at the linkage **A**.

Check the rubber bushing in the pedal for wear and replace as needed.

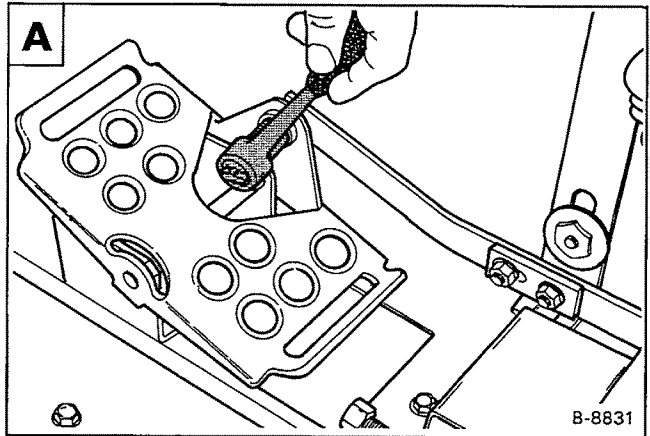

Remove the two mounting bolts **B**.

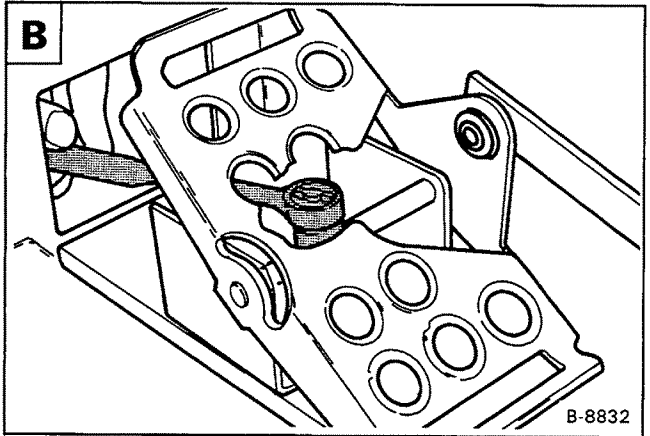

Remove the pedal from the loader **C**.

### Adjustment

After installing the pedal, adjust the pedal so that there is clearance under the rear of the pedal and the valve spool will travel full stroke without the pedal hitting.

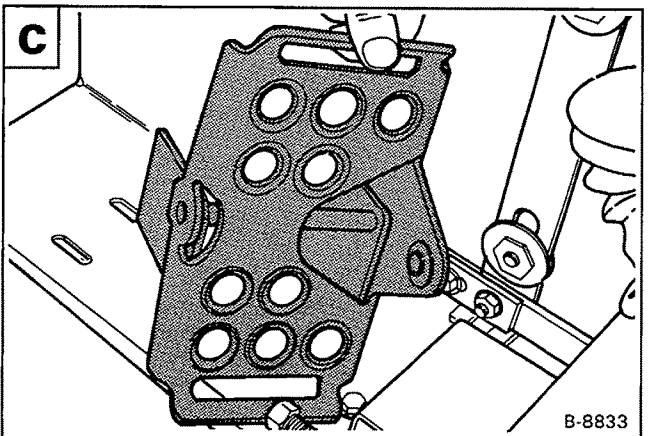

If the linkage bar is to be removed, disconnect it at the valve. Pull it out through the front of the loader **D**.

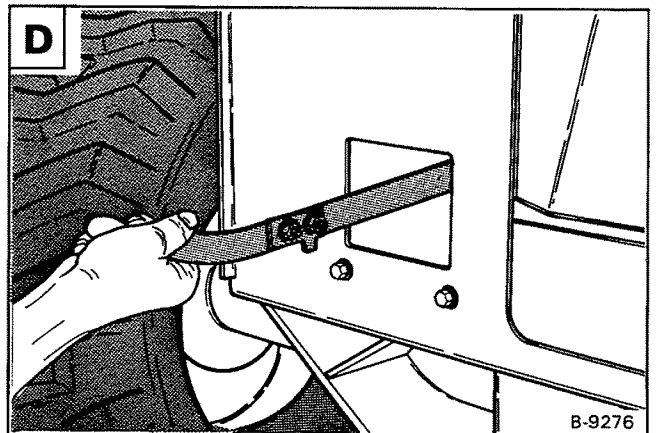

## PEDAL LOCK LINKAGE

### Adjustment

Check the pedal lock linkage so it is free and lock the pedals **A**.

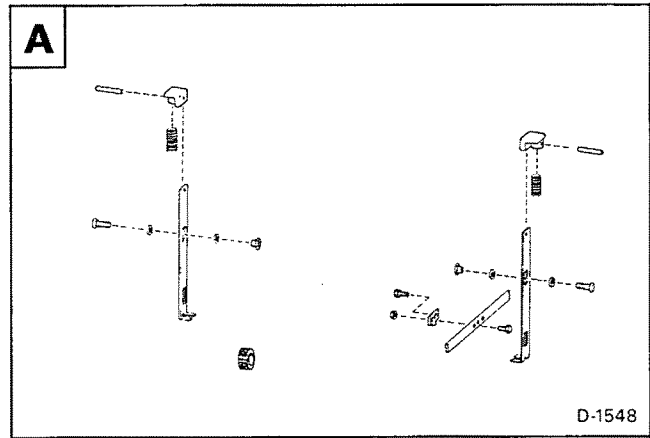

Check that the tab goes into the slot at the lock **B**.

If not, loosen the bolts (Item 1) and adjust the tab for engagement **B**.

Installation: Tighten the bolts to 25 ft.-lbs. (34 Nm) torque.

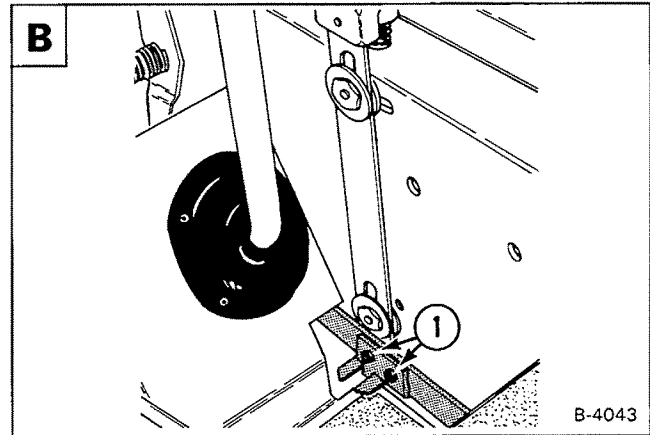

## WARNING

Adjust locking tabs on pedal control linkage so that lift and tilt control pedals are locked in neutral when seat bar is up.

W-2104-1285

## HYDROSTATIC SYSTEM

	Page Number
FRONT AND SIDE PANELS (S/N 19999 & Below)	
Removal and Installation . . . . .	3-3
FRONT AND SIDE PANELS (ONE PIECE) (S/N 20001 & Above) & 843B	
Removal and Installation . . . . .	3-9
HYDROSTATIC FLUID FILTER HOUSING	
Removal and Installation . . . . .	3-53
HYDROSTATIC MOTOR	
Disassembly and Assembly . . . . .	3-37
Inspection . . . . .	3-41
Removal and Installation . . . . .	3-36
Timing the Hydrostatic Motor . . . . .	3-42
High Pressure Hose Routing . . . . .	3-42
HYDROSTATIC PUMPS	
Checking Charge Pressure . . . . .	3-44
Checking the High Pressure Relief/Replenishing Valves . .	3-42
Disassembly and Assembly . . . . .	3-45
Hydrostatic Pump Rear Mount . . . . .	3-52
Inspection . . . . .	3-50
Removal and Installation . . . . .	3-44
Tow Valves . . . . .	3-51
HYDROSTATIC SYSTEM INFORMATION	
High Pressure Relief/Replenishing Valve Function . . . . .	3-2
PINTLE LEVER ARMS (S/N 26000 Thru 29869)	
Removal and Installation . . . . .	3-25
SERVO CONTROL	
Disassembly and Assembly . . . . .	3-24
Removal and Installation . . . . .	3-23
STEERING LEVERS (S/N 16191 & Below)	
Removal and Installation . . . . .	3-4
Repairing the Steering Levers . . . . .	3-5
STEERING LEVERS (S/N 16192 & Above) & 843B	
Removal and Installation . . . . .	3-12
Repairing the Steering Levers . . . . .	3-13
STEERING LINKAGE (S/N 16191 & Below)	
Removal and Installation . . . . .	3-7
Repairing the Pintle Lever . . . . .	3-8
Steering Linkage Adjustment . . . . .	3-6
STEERING LINKAGE (S/N 16192 Thru 25999) & 843B	
Removal and Installation . . . . .	3-15
Repairing the Pintle Lever . . . . .	3-16
Steering Linkage Adjustment . . . . .	3-14

HYDROSTATIC SYSTEM

Page 132 - B08M027201B1001 - 02/10/2009 17:56:11 - Printed by Ken Cook Co. - epxr - exe (v2.24.3 8/25/2008)