



DRIVE SYSTEM

	Page Number
AXLES, SEALS AND BEARINGS	
Installation	4-5
Removal	4-4
FINAL DRIVE CHAIN	
Installation	4-8
Removal	4-8
PARKING BRAKE	
Adjustment	4-1
Block and Pucks	4-2
Removal and Installation	4-1
REDUCTION GEARCASE	
Checking Reduction Gearcase	4-11
Disassembly and Assembly	4-11
Reduction Gearcase Seal	4-17
Removal and Installation	4-10

**DRIVE
SYSTEM**



bobcat

4 DRIVE SYSTEM

PARKING BRAKE

Adjustment

When the brake is in good condition and adjusted correctly, it will keep the loader from moving in the parked position.

Loosen the nut (Item 1) and turn the linkage rod to adjust the brake pedal. There must be 3/4" (19 mm) free play under the rear edge of the pedal **A**.

NOTE: If the correct adjustment cannot be obtained by turning the brake linkage rod, the brake lever must be adjusted.

Remove the front panel (See Page 3-3 or 3-9 for the correct procedure).

Loosen the bolt at the brake lever. Do not remove the bolt **B**.

Using pry bar and hammer, hit the top of the bolt until the brake lever is loose **B**.

Remove the bolt and lever. Turn the cam pin counterclockwise until the brake pucks make contact with the brake discs.

Install the lever and bolt. Tighten the bolt to 65-70 ft.-lbs. (88-95 Nm) torque.

Install the front panel.

Readjust the brake as outlined above.

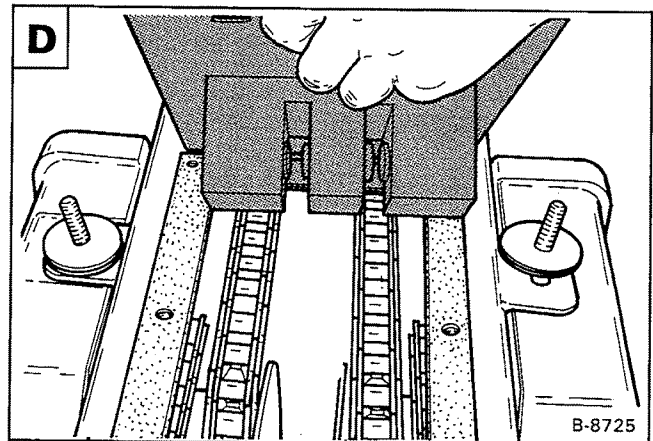
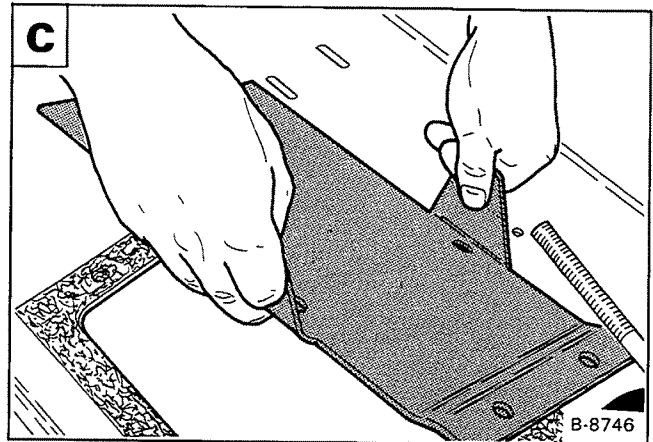
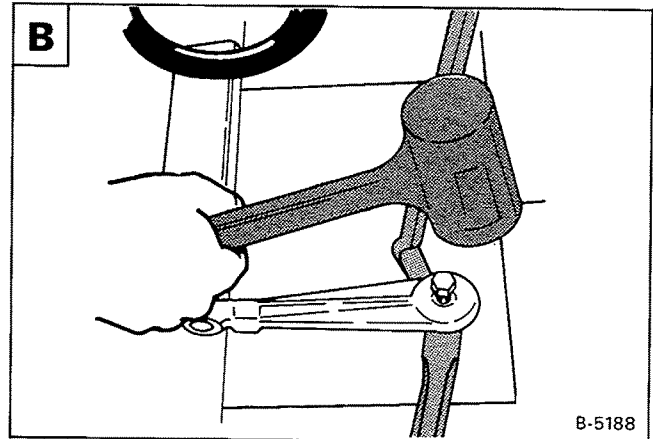
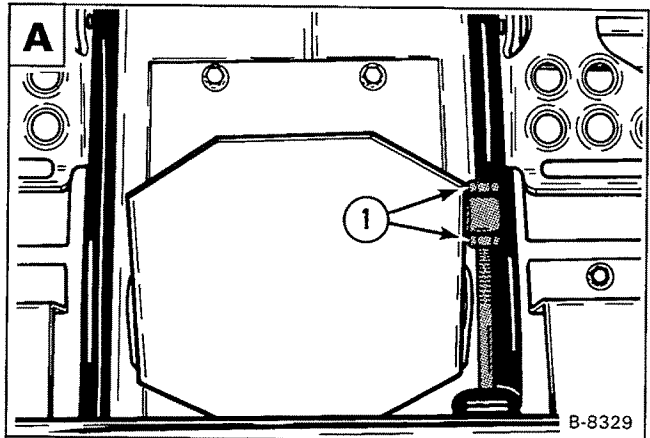

Removal and Installation

Remove the front panel (See Page 3-3 or 3-9 for the correct procedure).

Remove the steering levers (See Page 3-4 or 3-12 for the correct procedure).

Remove the cover and brake block **C**.

Installation: Align the brake discs so they are centered between the brake pucks **D**.

PARKING BRAKE (Cont'd)

Remove the snap rings at the discs **A**.

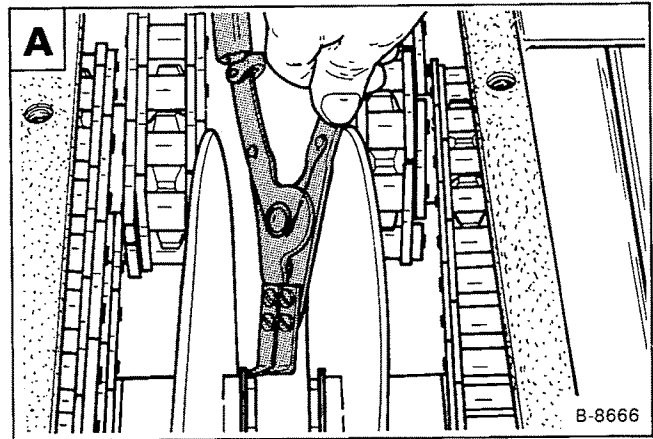

Remove the brake discs **B**.

Check the brake disc for damage. Replace the discs as needed.
DO NOT grind the discs.

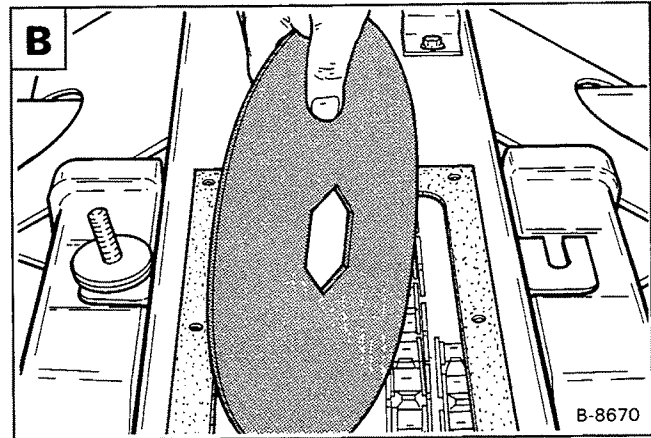

Block and Pucks

Remove the brake lever **C**.

Installation: Tighten the bolt to 65-70 ft.-lbs. (88-95 Nm) torque.

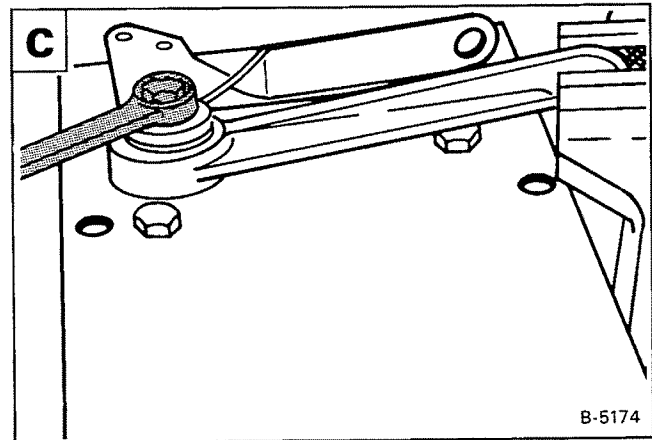

Remove the bolts which fasten the block to the cover **D**.

Installation: Put Loctite on the bolts and tighten to 65-70 ft.-lbs. (88-95 Nm) torque.

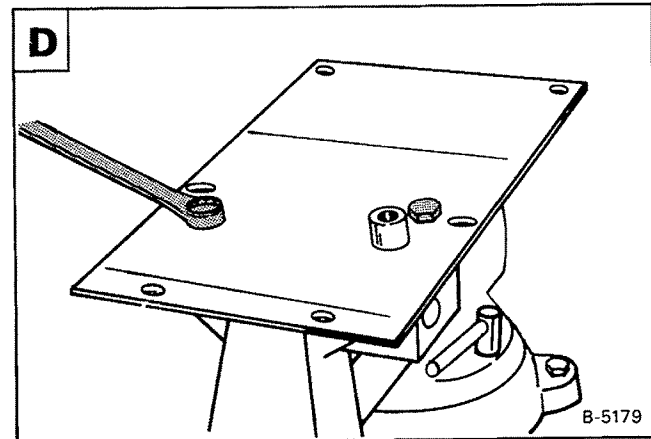

PARKING BRAKE (Cont'd)

Remove the pucks from the block **A**.

Check the pucks for wear or damage. The pucks can be turned 180° and the smooth side used again.

Check for a good fit between the pucks and block bore. They must slide in and out freely.

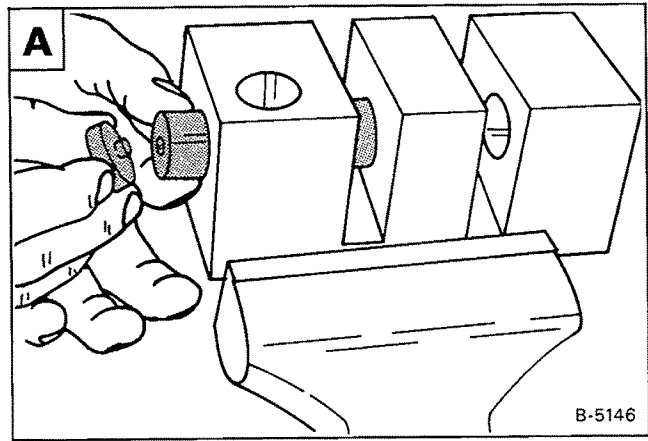

Install a new O-Ring on the cam pin **B**.

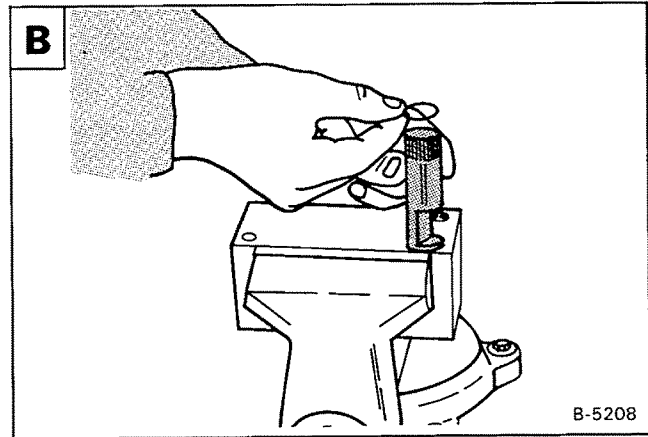

Clean and dry the block and put a bead of R.T.V. sealant on the brake block **C**.

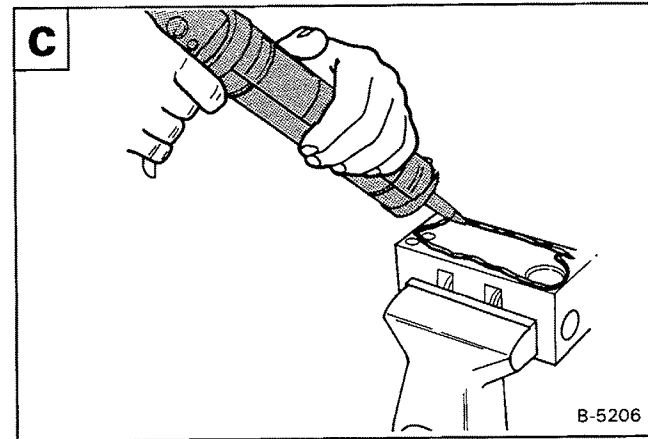

Install the center cover on the brake block **D**.

Install the bolts and tighten.

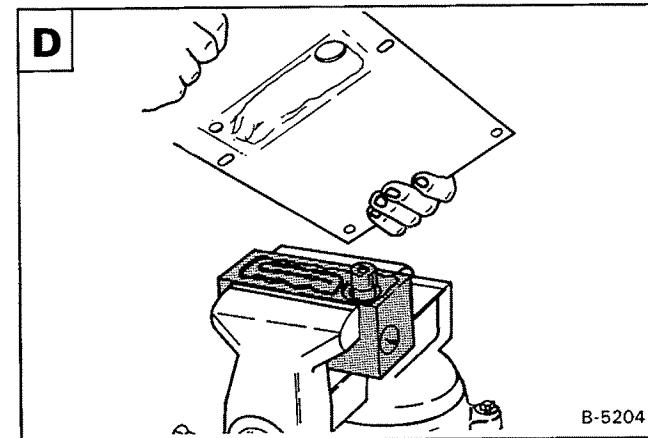

AXLES, SEALS AND BEARINGS

Removal

NOTE: The removal and installation of the four axles use the same procedure.

The tools listed will be needed to do the following procedure:

MEL-1242 — Port-a-Power

MEL-1053 — Axle Seal Tool

MEL-1202C — Axle Bearing Race Service Set

Lift and block the loader (See Page 1–2 for the correct procedure).

Remove the wheel and tire assembly.

Raise the operator cab (See Page 1–7 for the correct procedure).

Remove the front panel (See Page 3–3 or 3–9 for the correct procedure).

Remove the steering levers (See Page 3–4 or 3–12 for the correct procedure).

NOTE: The following procedure will work for both the front and rear axles, but for the rear axles the hydrostatic pumps will have to be removed (See Page 3–25 for the correct procedure).

Remove the chaincase covers and brake assembly (See Page 4–1).

Remove the drive chain(s) (See Page 4–8).

Put a wrench on the bolt at the sprocket; front **A**, rear **B**.

Loosen the bolt (inside the chaincase) at the sprocket by turning at the axle hub.

Installation: Put Loctite on the bolt and tighten to 475-525 ft.-lbs. (644-712 Nm) torque.

Install the Port-a-Power ram jack between the two sprockets **C**. Push the axle out until the ram jack is at the end of the stroke. Add a spacer and push the axle out again. Repeat this procedure until the axle is out of the sprocket.

Remove the sprocket from the chaincase. Install the bearing cup puller tool into the axle tube **D**. Remove the bearing cup from the axle tube.

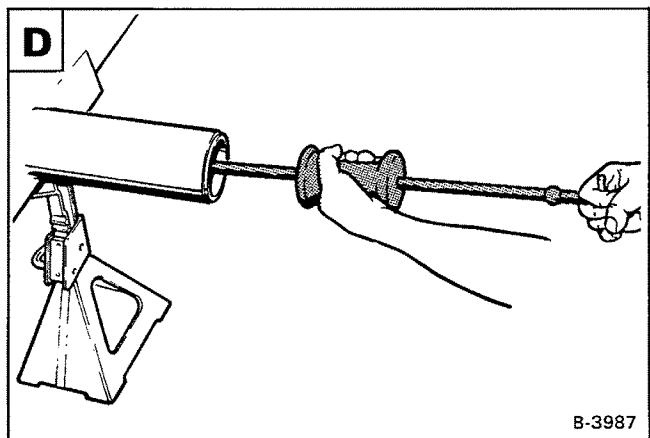
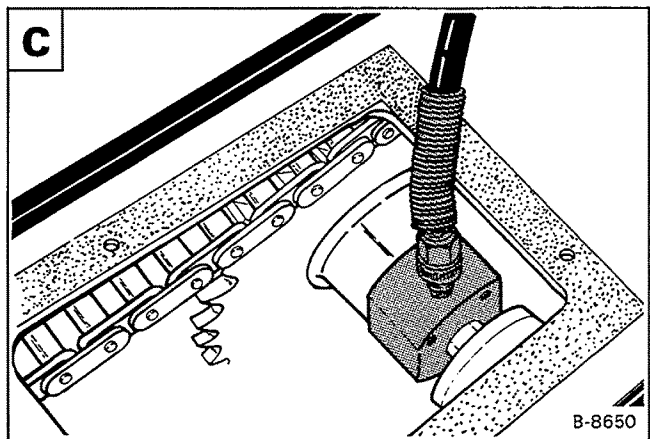
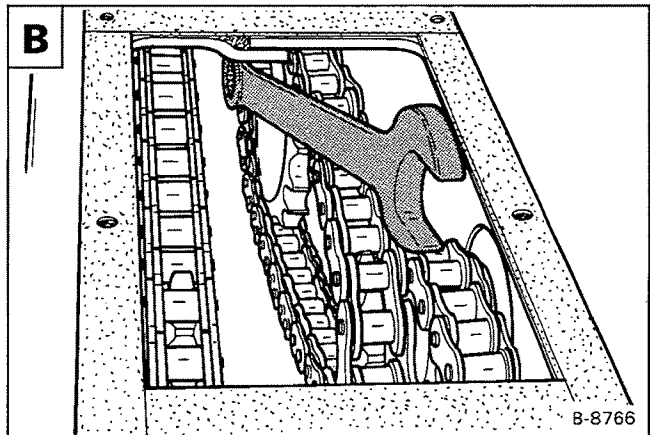
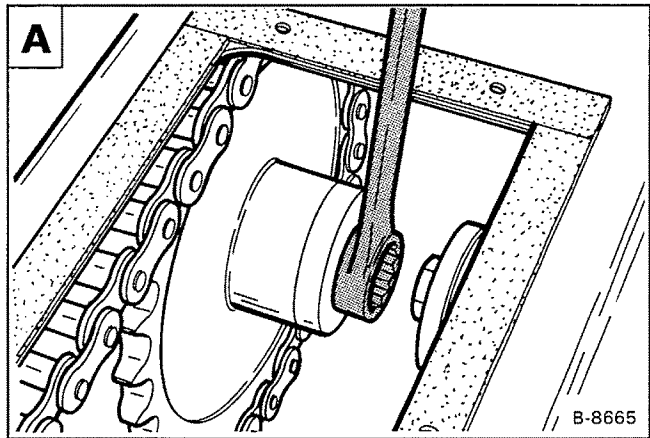

AXLES, SEALS AND BEARINGS (Cont'd)

Using a long punch, remove the inside bearing cup **A**.

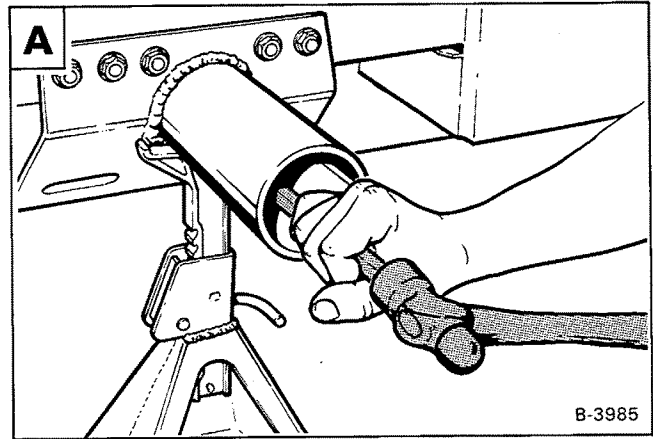

Use a puller and remove the outer bearing from the axle **B**.

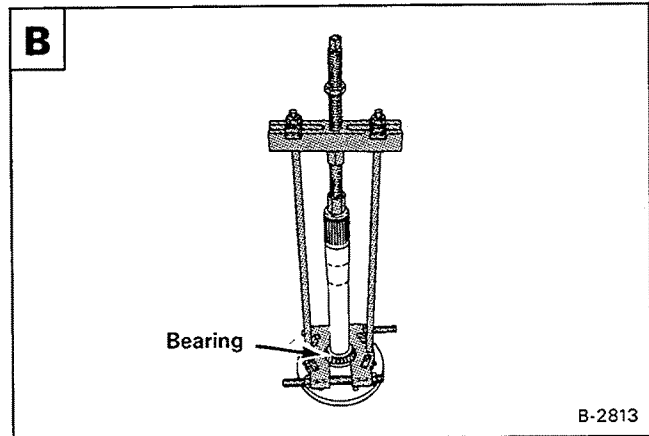

Using a hammer and chisel, remove the wear sleeve (Item 1) from the axle **C**. Make sure not to damage the axle.

Clean and check all the parts for wear and damage. Replace the parts as needed.

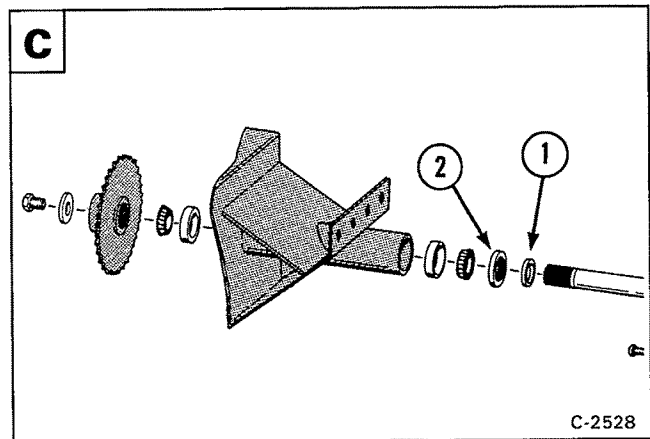

Installation

Put Loctite on the inside of the wear sleeve **D**. Install the wear sleeve (Item 1) on the axle **C**.

NOTE: When the bearing is installed, it will also position the wear ring in its correct location.

Lubricate the axle seal (Item 2) and install the seal on the axle with the open side toward the chaincase **C**.

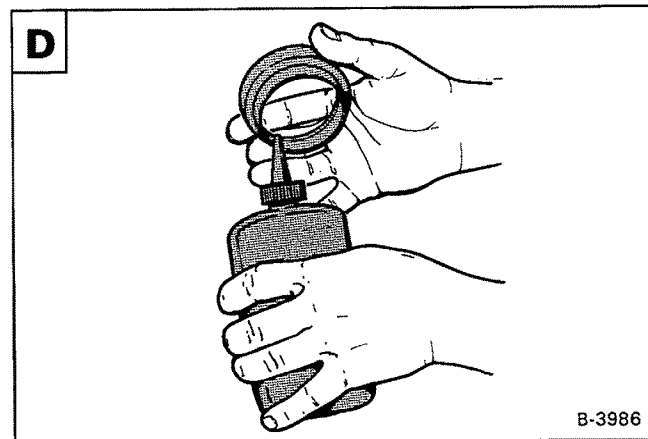

AXLES, SEALS AND BEARINGS (Cont'd)

Using an arbor, install the outer bearing on the axle **A**.

Make sure the bearing seats correctly on the axle **A**.

Press only on the inner race of the bearing. This will also position the wear ring correctly.

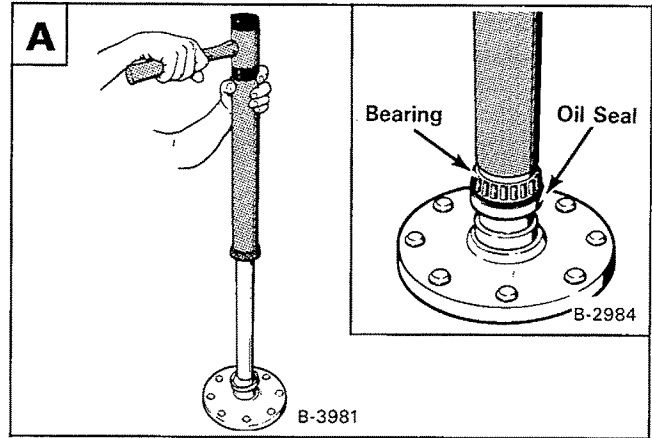

Install the outer bearing cup using the correct size bushing driver **B**.

Install a long threaded bolt into the axle tube.

Install the correct size cup driver.

Install a washer and nut.

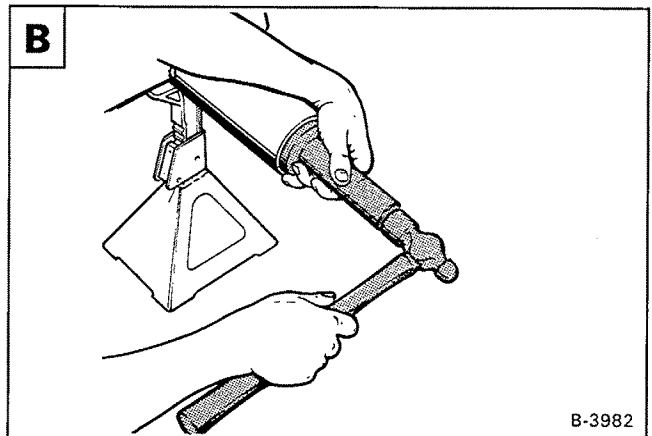

Inside the chaincase, install the new bearing cup, the bearing cup driver tool, washer and nut **C**.

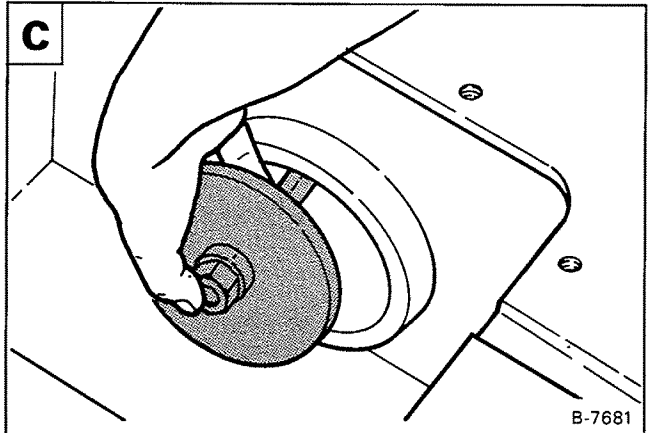

Have a second person hold the wrench on the nut in the chaincase **D**.

Turn nut on the outside of the axle tube until the inner bearing cup is on its seat.

NOTE: Pack the inner and outer axle bearing with grease before installing the axle assembly.

Install the axle assembly into the axle tube.

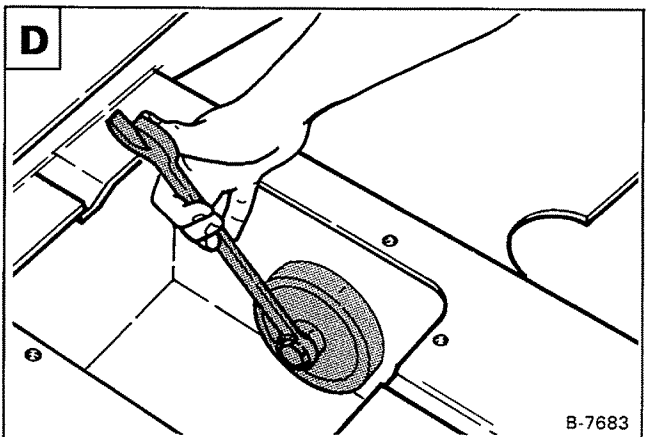

AXLES, SEALS AND BEARINGS (Cont'd)

Put the sprocket into the chaincase.

NOTE: The long part of the sprocket hub goes toward the inside for the front axle and the outside for the rear axle.

Install the spring over the axle tube [A].

Install the inner halves of the installation tool behind the out axle seal [A].

Install the outer halves of the tool on the inner halves [B].

Install the spring on the tool [B].

Push the axle inward, install the inner bearing and sprocket on the axle.

Put the installation tool in contact with the axle tube. Install the washer and bolt (inside the chaincase) and pull the axle into position.

Using a large hammer, hit the axle hub until it is in the correct position [A].

Remove the spring from the tool. Remove the outer halves of the tool [D]. Remove the inner halves from the axle [D].

Tighten the sprocket bolt to the correct torque. Check the axle end play. It must be between 0.00 – 0.10" (0,254 mm).

If not, replace the washer, at the sprocket bolt to get the correct end play.

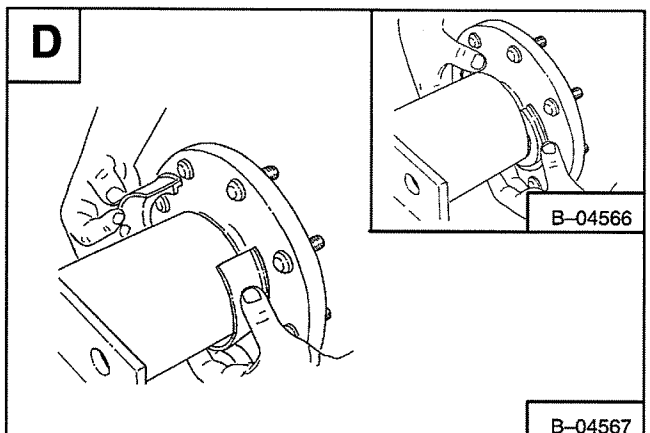
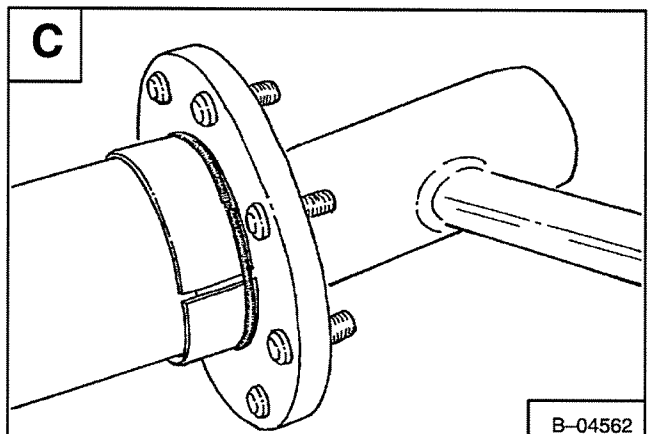
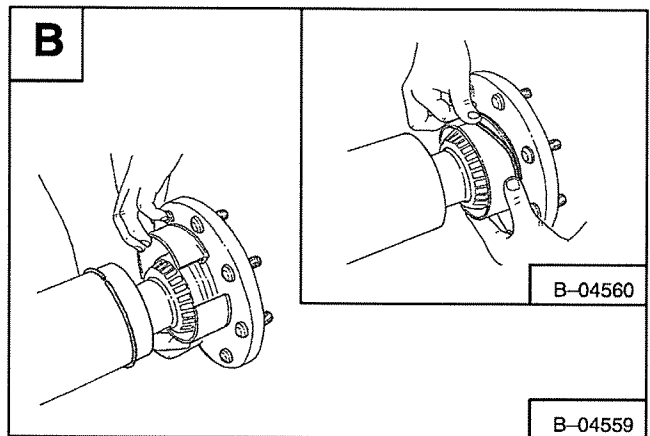
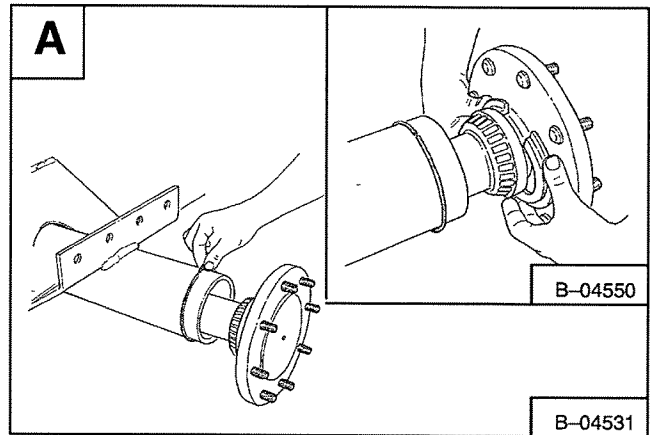

FINAL DRIVE CHAIN

Removal

MEL1269 – Chain Breaker
MEL1037 – Chain Link Press
MEL1049 – Chain Puller Tool

Lift and block the loader. (See Page 1–2 for the correct procedure.)

Raise the operator cab (See Page 1–7 for the correct procedure.)

Remove the front panel (See Page 3–3 or 3–9 for the correct procedure.)

Remove the steering levers (See Page 3–4 or 3–12 for the correct procedure.)

Remove the hydrostatic pump (See Page 3–25 for the correct procedure.)

Remove the chaincase covers and brake assembly (See Page 4–1.)

Remove the fluid from the chaincase using a transfer pump.

NOTE: Check the chain for the connector link. If there is no connector link, make separation of the drive chain at any link.

Break the front chain using the chain breaker tool [A].

Remove the chain from the chaincase [B].

Remove the rear chain using the same procedure.

Installation

Push the axle out of the axle tube (See Page 4–4.)

Loosen the bolts at the reduction gearcase housing [C].

Put the drive chain(s) into the chaincase [D].

Put the drive chain over the reduction gearcase sprocket and pull the ends out and above the chaincase.

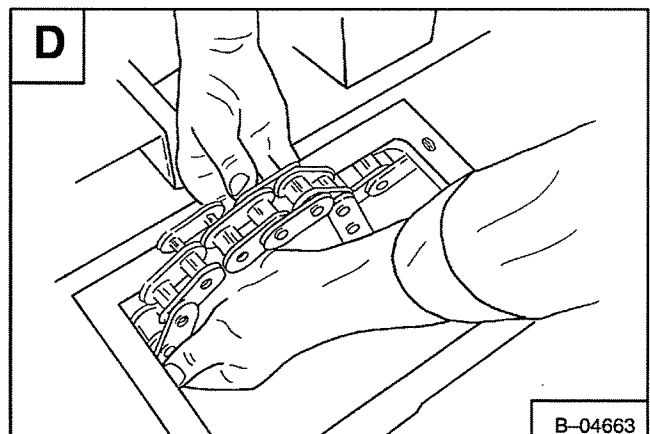
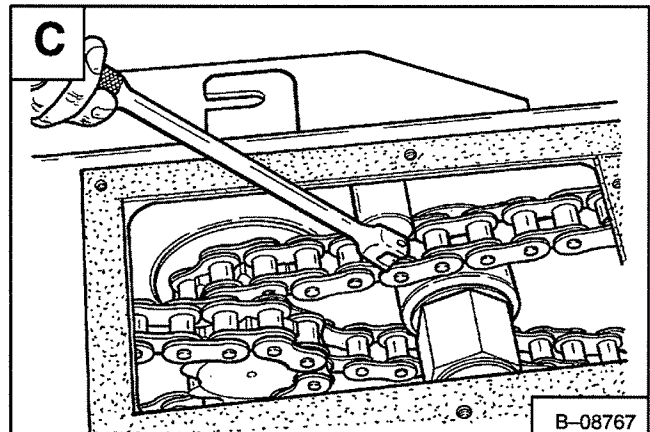
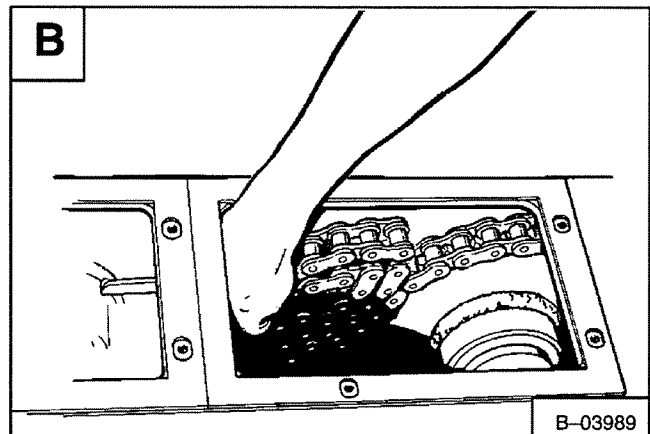
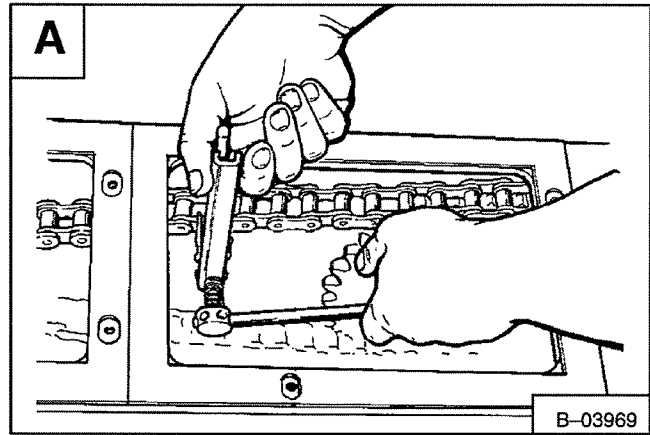

FINAL DRIVE CHAIN (Cont'd)

Put a flat bar under the chain across the chaincase **A**.

Clamp the bar to the chaincase.

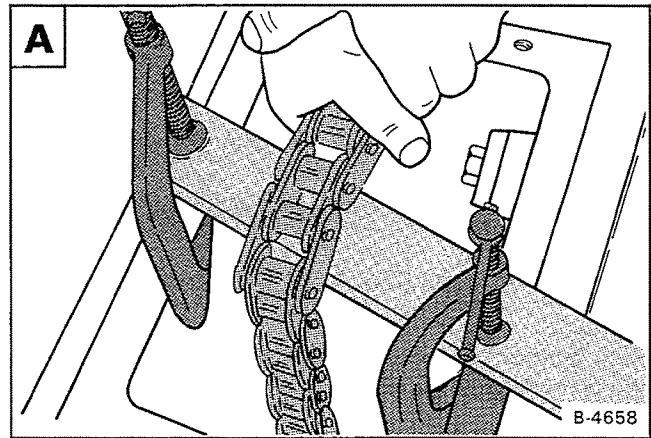

Install the connector link and plate **B**.

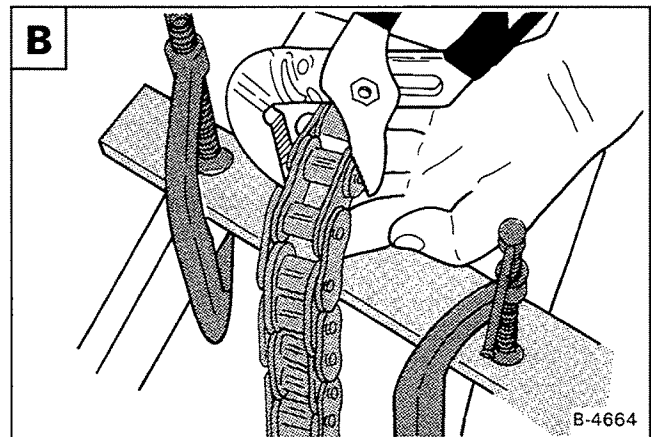

Install the chain link press **C**.

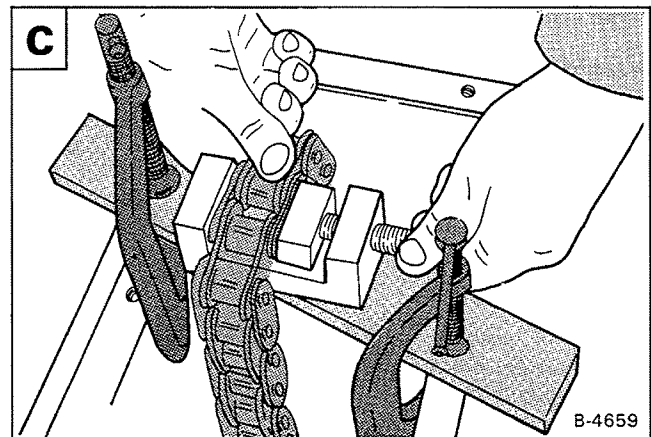

Tighten the chain link press to 180 ft.-lbs. (244 Nm) torque to press the connector plate into position **D**.

Remove the chain link press and flat bar.

Install the sprocket and axle (See Page 4-6).

Center the reduction gearcase between the front and rear drive chains. Tighten the bolts to 220-245 ft.-lbs. (300-330 Nm) torque.

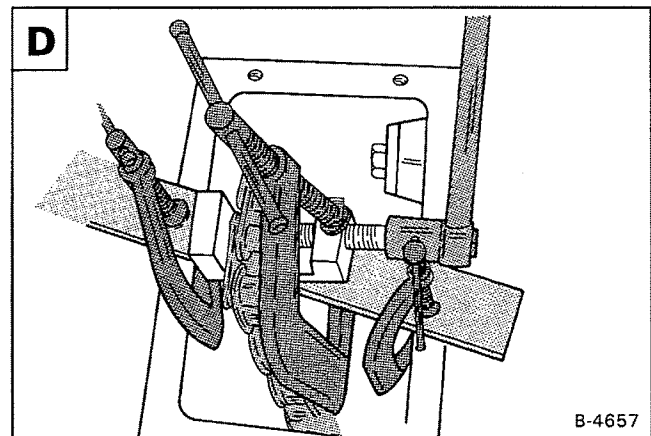

REDUCTION GEARCASE

Removal and Installation

Lift and block the loader (See Page 1–2 for the correct procedure).

Remove the hydrostatic motor (See Page 3–17 for the correct procedure).

Raise the operator cab (See Page 1–7 for the correct procedure).

Remove the front panel (See Page 3–3 or 3–9 for the correct procedure).

Remove the steering levers (See Page 3–4 or 3–12 for the correct procedure).

Remove the chaincase covers and brake assembly (See Page 4–1).

Remove the fluid from the chaincase using a transfer pump.

Remove the front chain (See Page 4–8).

Put a floor jack under the reduction gearcase **A**.

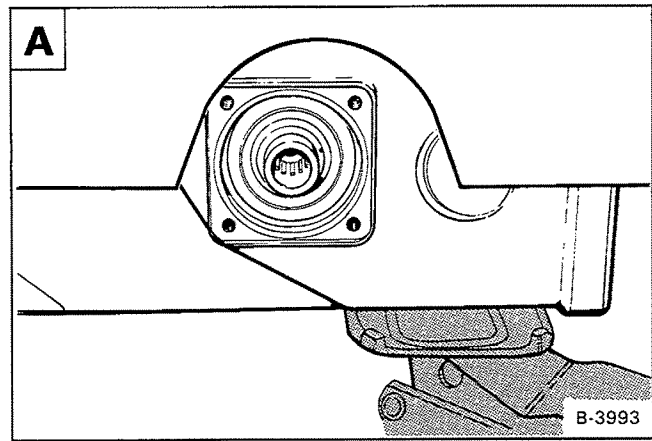

Remove the bolts which fasten the gearcase to the chaincase **B**.

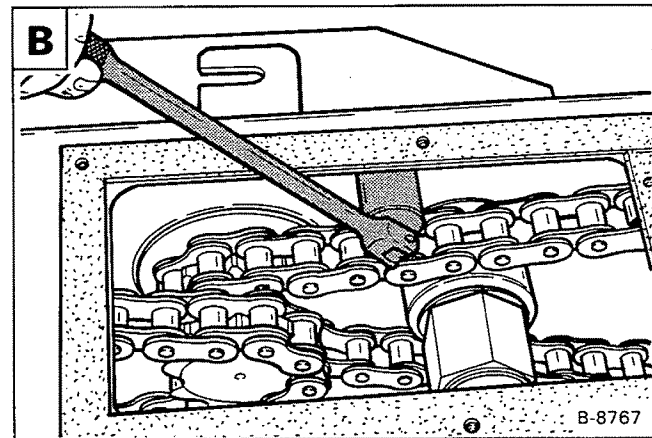

Installation: Tighten the bolts to 220-245 ft.-lbs. (300-330 Nm) torque.

Remove the bolt (Item 1) and washer (Item 2) **C**. Drive the shaft into the chaincase until it clears the bearing (Item 3) **C**. Remove the rear chain from the gearcase sprocket. Lower the gearcase to the floor.

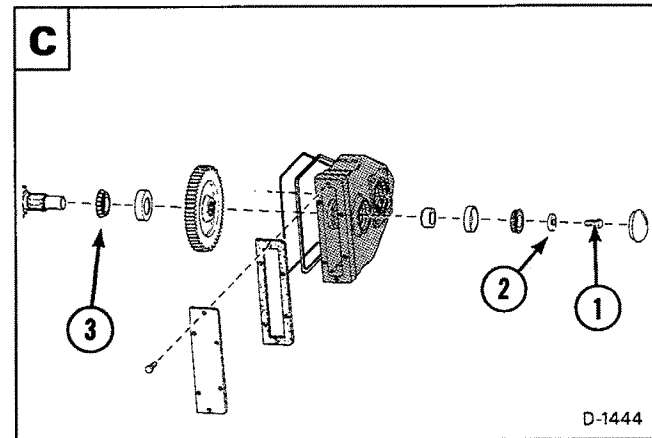

Installation: After complete assembling of the gearcase, install a 1" (25,4 mm) longer bolt (Item 1), than normal bolt used, and washer (Item 2) **C**.

Drive the shaft inward until it clears the bearing (item 3) **C**. Make sure not to damage the bolt. Lift the gearcase into position, angle the shaft which allows the installation of the rear drive chain.

Pull the shaft back into position. Remove the longer bolt, put the regular bolt back in position and tighten to 210-235 ft.-lbs. (285-305 Nm) torque.

Complete the installation of the reduction gearcase.

REDUCTION GEARCASE (Cont'd)

Checking Reduction Gearcase

Before disassembly of the gearcase do the following checks:

Install a dial indicator on the input shaft **A**. The end play must be between 0.00 - 0.010" (0,0254 mm). If not the following parts may need replacing: Bearing, bearing cups, gear or gearcase housing.

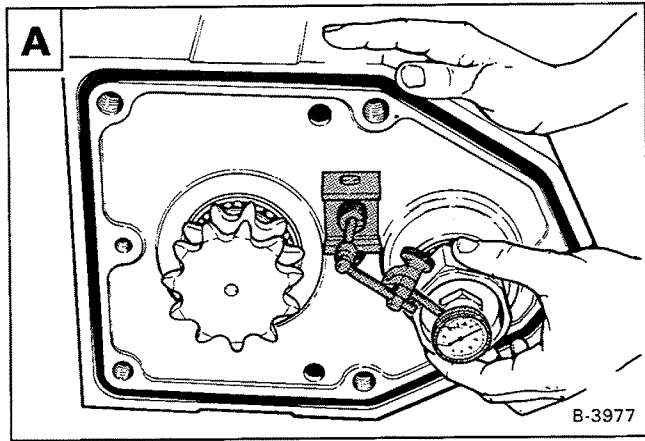

Install the dial indicator on the output shaft **B**. The end play must be between 0.00 - 0.010" (0,0254 mm). If not, the following parts may need replacing: Bearing, bearing cups, gear or gearcase housing.

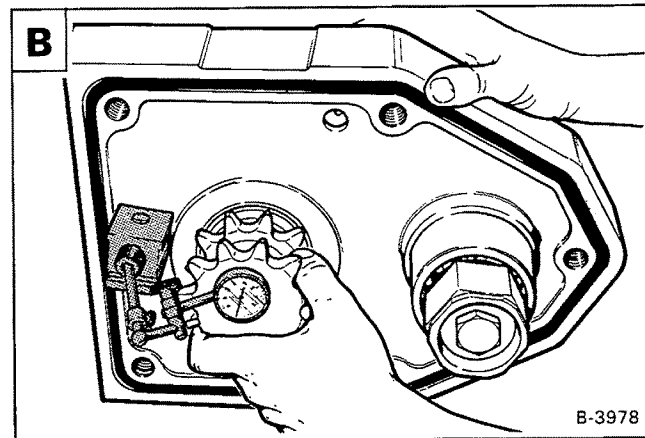

Remove the seal.

Install a feeler gauge between the teeth of the gears **C**.

The back lash must be between 0.003-0.009" (0,076-0,228 mm). If not, the following parts may need replacing: Large gear or the shaft.

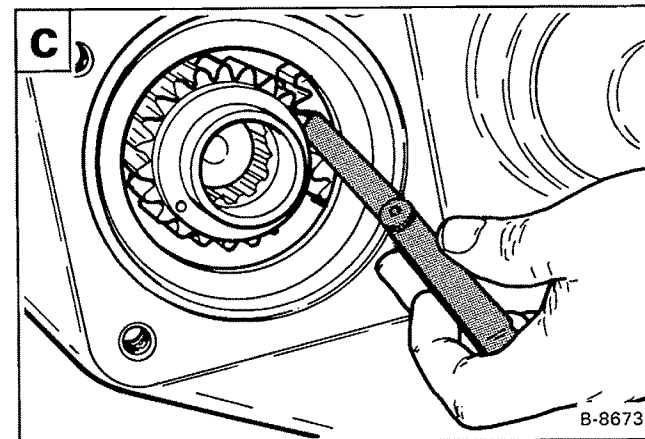

Measure the bore diameter for the seal. Correct diameter is 3.750" ± 0.001" (95,25 mm ± 0,025 mm). Install a dial indicator on the output shaft. Set the indicator so the stylus is against the pilot bore for the drive motor. Rotate the shaft 360 degrees. Maximum run-out should not exceed 0.009" (0,23 mm). If either check (Bore I.D. or Run-Out) is not within the specifications, replace the gearbox.

Disassembly and Assembly

The tool listed will be needed to do the following procedure:

MEL-1047 — Seal Installation Tool

Remove the bolts from the end plate **D**.

Installation: Tighten the bolts to 13-14 ft.-lbs. (16-18 Nm) torque.

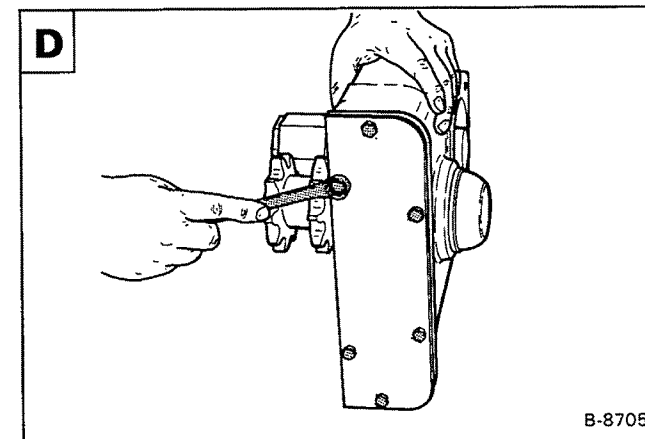

REDUCTION GEARCASE (Cont'd)

Remove the end plate **A**.

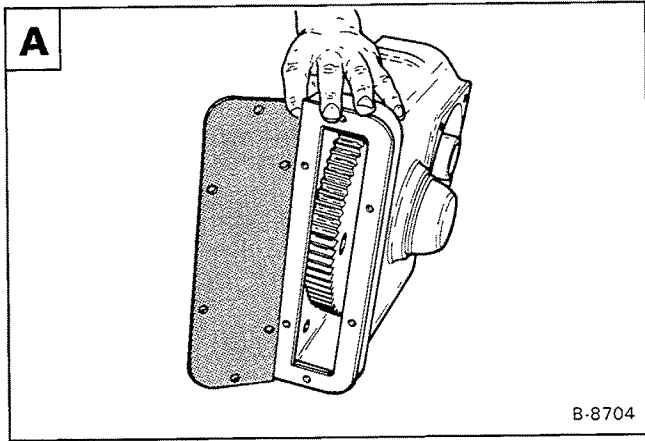

Remove the dust cap **B**.

Installation: Put "Boretite" sealant on the edge of the dust cap before installing it.

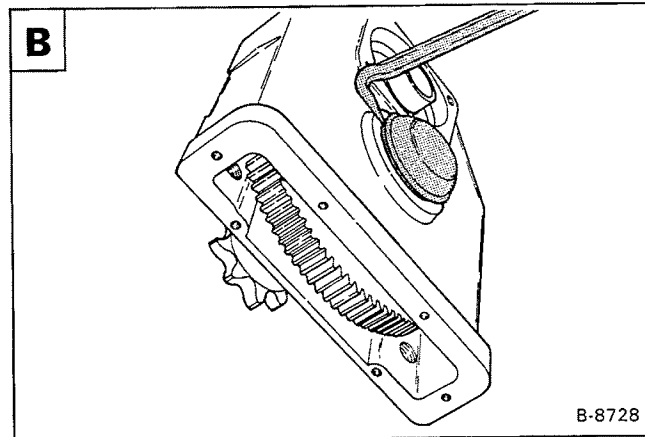

Remove the bolt from the output shaft **C**.

Installation: Put Loctite on the bolt and tighten to 210-235 ft.-lbs. (285-305 Nm) torque.

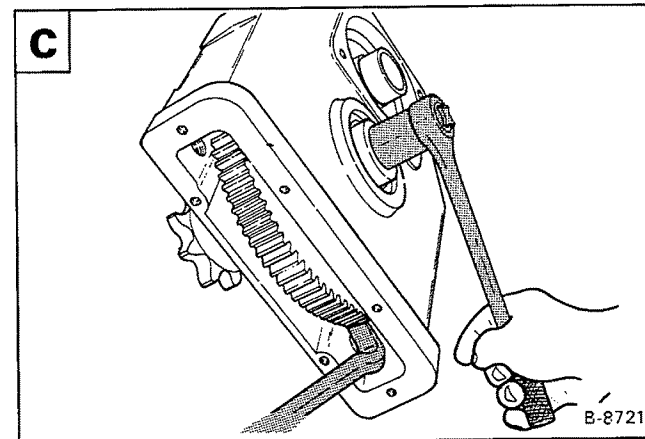

Remove the bolt and washer **D**.

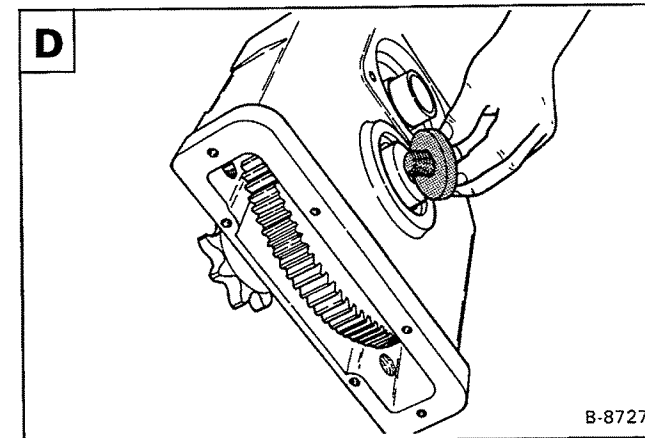

REDUCTION GEARCASE (Cont'd)

Remove the bolt at the disc hub **A**.

Installation: Put Loctite on the bolt and tighten to 210-235 ft.-lbs. (285-305 Nm) torque.

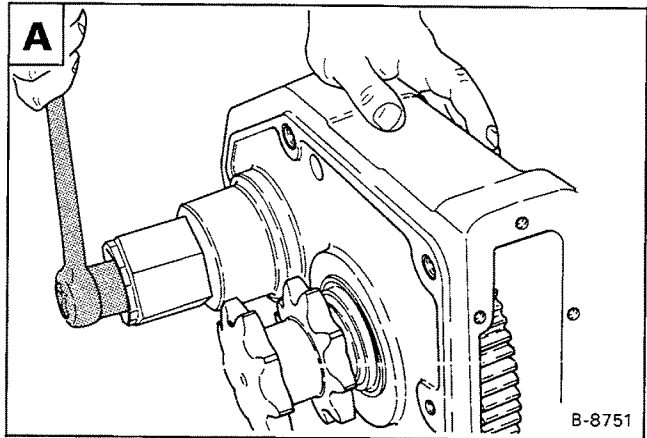

Remove the bolt and washer **B**.

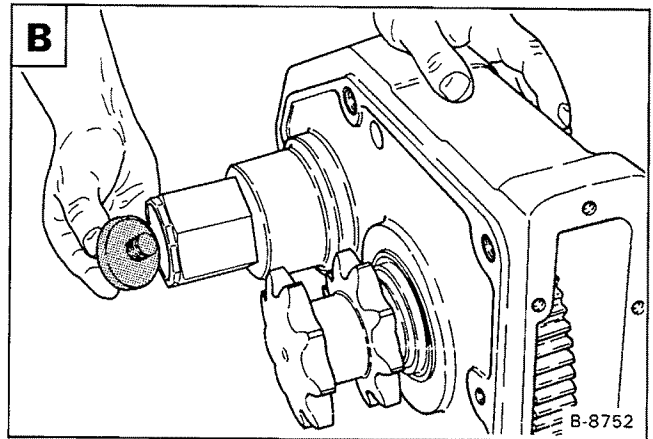

Remove the disc hub and key **C**.

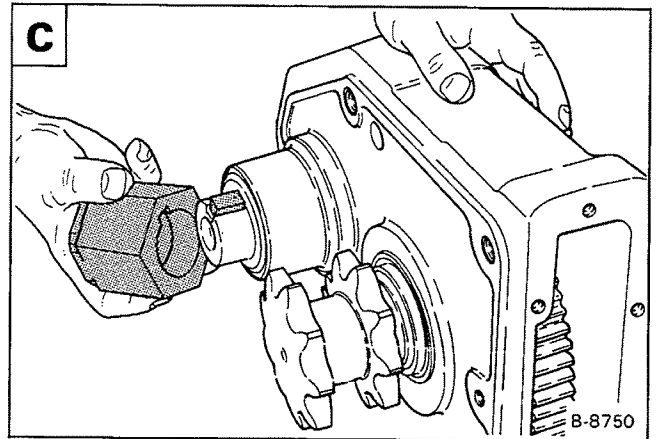

Put the gearcase housing in the press and remove the output shaft **D**.

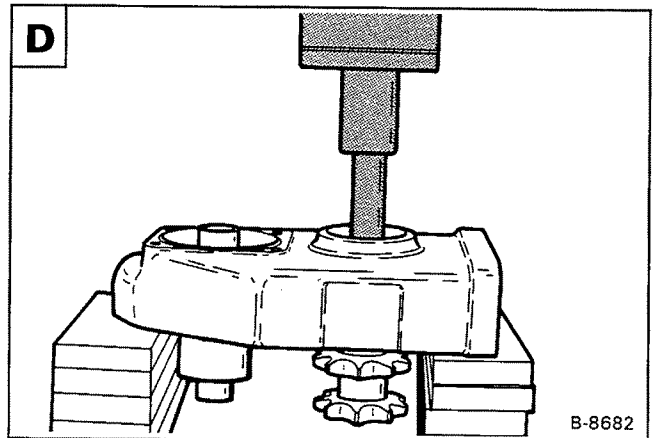

REDUCTION GEARCASE (Cont'd)

Remove the bearing **A**.

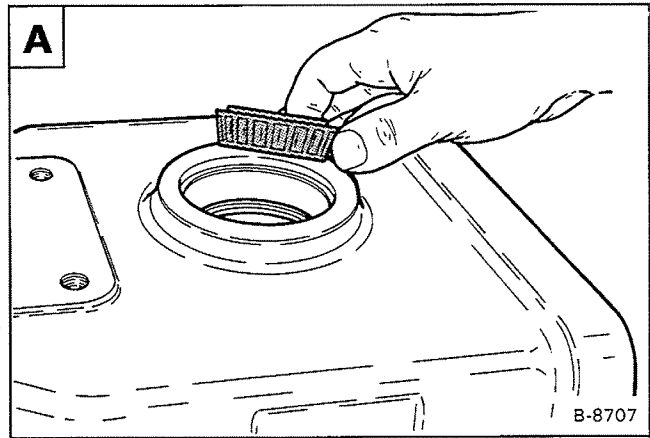

Remove the spacer **B**.

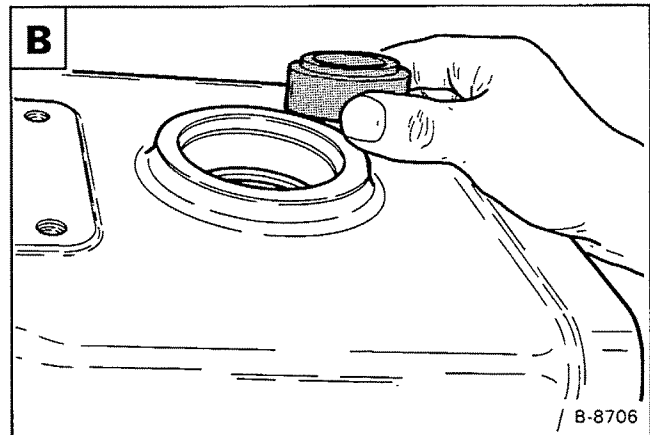

Remove the output shaft **C**.

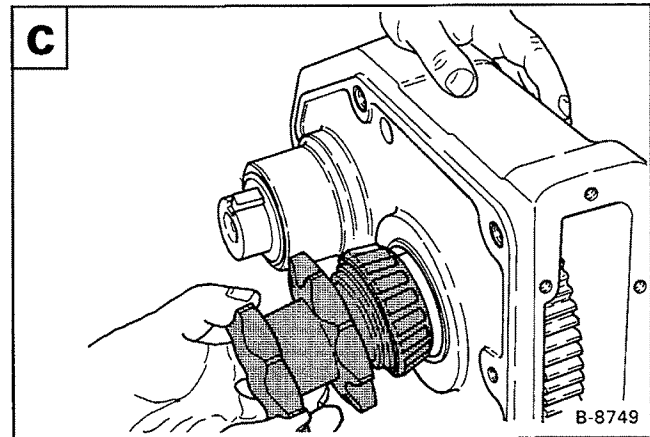

Remove the large gear **D**.

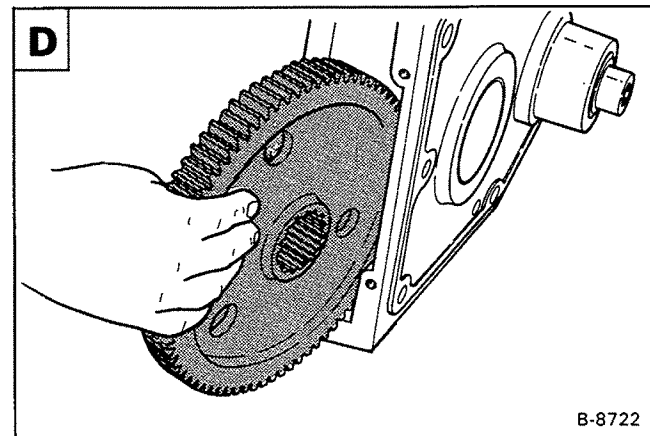

REDUCTION GEARCASE (Cont'd)

Remove the bearing at the input shaft **A**.

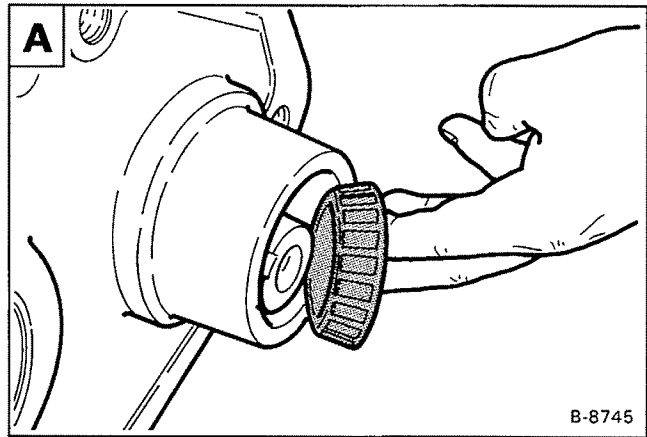

Use a press and remove the input shaft **B**.

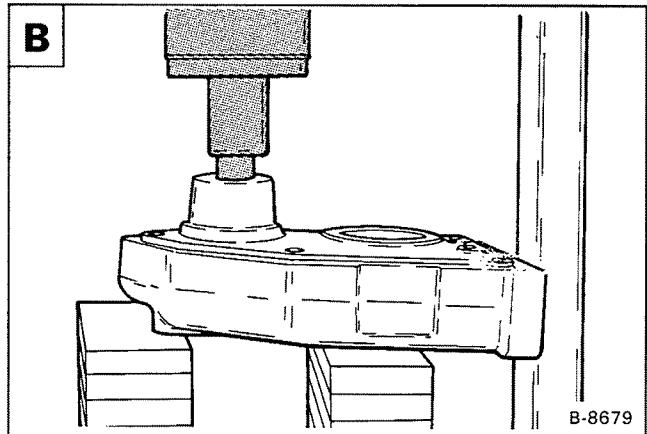

Remove the input shaft assembly from the housing **C**.

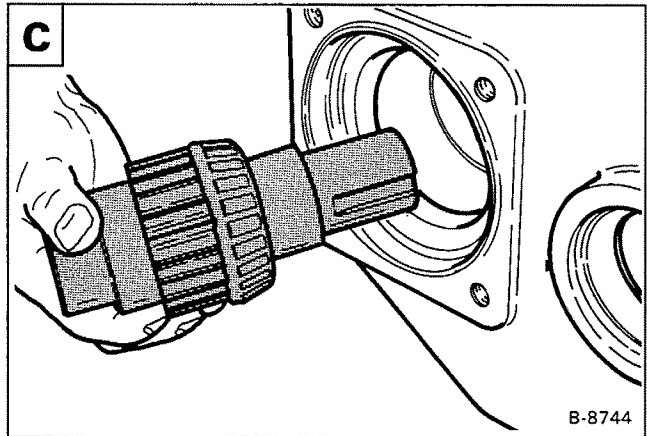

Use a punch and hammer and remove the bearing cups as needed **D**.

Installation: Use a press and bearing cup driver to install the bearing cup.

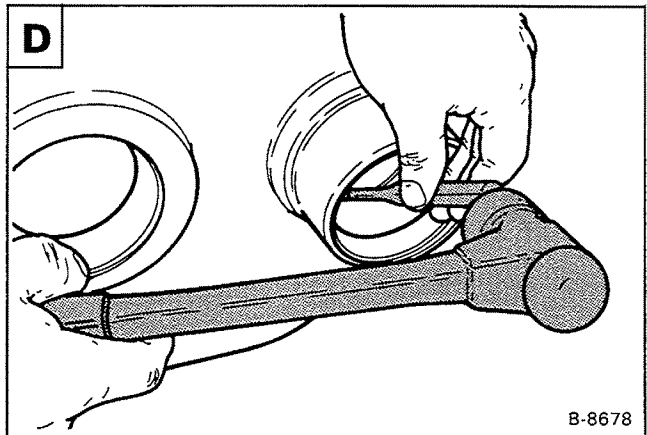

REDUCTION GEARCASE (Cont'd)

Installation

Install a new Quad-ring. Install the back-up washer **A**.

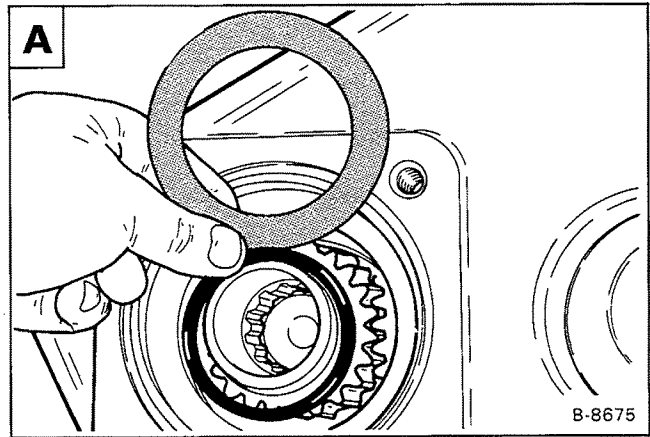

Install the new seal using the seal installation tool **B**.

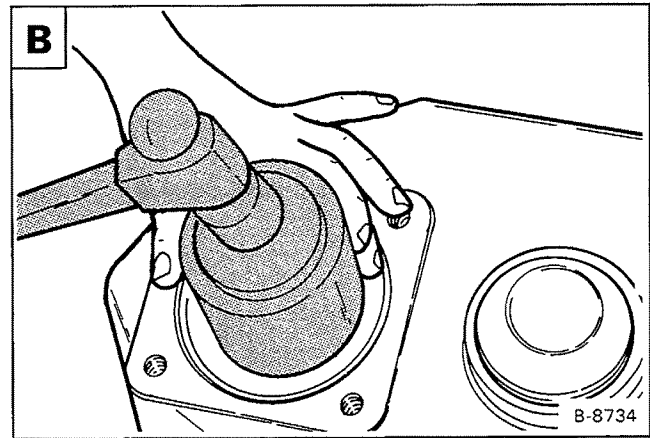

REDUCTION GEARCASE (Cont'd)

Reduction Gearcase Seal

The tool listed will be needed to do the following procedure:

MEL-1047 — Seal Installation Tool

It is not necessary to remove the reduction gearcase to replace the seal at the input shaft, use the following procedure.

Lift and block the loader (See Page 1—2 for the correct procedure).

Remove the hydrostatic motor (See Page 3—17 for the correct procedure).

Use a punch and hammer and bend the edge of the seal inward **A**.

Use a screwdriver, pry the seal from the housing **B**.

Remove the washer. Replace the Quad-ring **C**.

Install the new seal using the seal installation tool **D**.

